

## Intellite<sup>3</sup>: A KNOWLEDGE BASED EXPERT SYSTEM FOR CONTROL STRUCTURE SYNTHESIS

Jeong Jun SONG and Sun Won PARK

Laboratory of Process Automation and Optimization, Department of Chemical Engineering,  
Korea Advanced Institute of Science and Technology, P.O. Box 131, Cheongryang, Seoul, Korea

(Received 16 March 1990 • accepted 26 April 1990)

---

**Abstract**—This work describes an expert system for synthesis and design of control systems for chemical processing plants. We also outline the knowledge representation schemes for the expert system with **object oriented programming** concepts on control system design, **control objectives** and their relationships to the knowledge structure shaped in this study — **Task Frame Net Model**.

Based upon various control objectives, shortcut calculations, and several heuristics including control idioms, **Intellite<sup>3</sup>** — the expert system developed in this study — synthesizes interactively the plausible control structures for a specified distillation column and screens effectively those alternatives to find out the most reasonable one in the context of overall control objectives, operability, and other operational requirements.

---

### INTRODUCTION

In today's highly integrated process plants with the push for tighter operating conditions, greater demands are being placed on the process control systems. Designing process control systems is a complex, open-ended collaborative activity. If we could characterize it completely, we could probably also write an algorithm for it. But we cannot, so we have to look to how design is performed by experienced designers, trying to understand how they solve design problems.

The obvious explanation as to why experienced designers are good at design is that they have experiences on what to rely, a basic understanding of the solution process. In the absence of profound theories of how design is done, the design and analysis of control systems can be greatly benefited from the use of a computer aided design package, and the only way computers can be utilized to do design is by implementing models of how experienced designers do it, using same information in a similar way. To the extent we can emulate experienced designers, computerized models of design may contribute both to a better understanding and to an improvement of the design process.

In recent years, significant research work has concentrated on the rationalization of the design process and the outline of comprehensive models for it, e.g., especially a knowledge based expert system which is

capable of dealing with chemical processing systems rather than simply being an adaptation from other control fields. Since artificial intelligence addresses the mechanization of large and complex, knowledge intensive tasks, most of the contributions have come from works in this area. Hence, it is expected that the knowledge based expert systems containing the knowledge in process control design will promote effective transfer of the specialized and intuitive heuristic knowledge to general process engineers. **Intellite<sup>3</sup> represents such an expert system.**

In this work, the general specifications and structure of a knowledge based control system analysis and design environment suitable for chemical process control are outlined and a specific realization, the expert system **Intellite<sup>3</sup>**, is discussed.

### EXPERT SYSTEM APPROACH TO CONTROL STRUCTURE SYNTHESIS

Chemical processes are large scale structured systems composed of many interconnected units through which process streams flow. The main task of chemical process control synthesis is to structure a system of measurements and manipulated variables so that certain control objectives are satisfied in the presence of disturbances. The control structure synthesis will then explore the question of which variables should be measured, which variables should be manipulated

and how these two sets of variables should be interconnected to form the control loops.

The configuration of control systems for a complete chemical process is required to satisfy a multitude of diversified control tasks such as regulating production and product quality at the specified levels, ensuring safe operation, acquiring optimum economic operating conditions, satisfying environmental regulations, and allowing for smooth transferring between operating conditions and emergency shutdowns or start-ups, etc.

Since this diversity of several requirements makes the process of designing control systems for complete chemical plants quite informal and the process design engineer is usually guided by his or her experience to design such a complex systems or these design procedures have long been relying on experience and intuition of some special control engineers. Those few experts have a large body of knowledge which they use to design control systems, but which is not readily available to others.

In the past two decades, research on developing logical procedures for the synthesis of process control systems have been carried out by several control engineers. Although their efforts have been contributed to deeper insights into process control system synthesis as well as to the development of general process synthesis procedures, but still now, no unified and well defined theory is available for the systematic designing and synthesizing of control structure for the complete plants with several design and operational requirements.

From the late 70s some attempts have been made to elevate process control structure design from the unit operations level to the higher level of plant control design (Govind and Powers, 1978, 1982; Umeda et al., 1978; Bristol, 1980; Morari, Arkun, Stephanopoulos, 1980a; Morari, Stephanopoulos, 1980b, 1980c; Arkun, Stephanopoulos, 1980, 1981; Stephanopoulos, 1983).

Recent advances in artificial intelligence and expert systems programming techniques permit the encoding of symbolic reasoning and make possible the creation of control systems where algorithmic knowledge and human experience can interact in a combined and unified environment.

The previous workers in expert system based control structure synthesis fields were Niida and Umeda (1986), Shinsky (1986), Stephanopoulos et al. (1987) and Birky et al. (1988, 1989). Among them, Niida and Umeda (1986) used two levels approach (Umeda, Kumayama, and Ichikawa, 1978) as a stem for the overall synthesis procedure. Shinsky (1986) presented an

expert system for distillation control system design. It selects the best control configuration for a distillation column using relative gain analysis, criteria of integrated error in relative units, and his heuristic knowledge in control area. This work is mainly based on analytical tools and can be used for offline control purposes in very small, well confined units, i.e., some special types of distillation columns. Birky et al. (1988, 1989) presented an expert system, DICODE, which configures the control structures on a distillation column. It uses GTST model (Modarres, M., T. Cadman, 1986) and some control idioms for building knowledge structures in the expert system and it mainly uses a heuristic knowledge for control configurations.

Stephanopoulos et al. (1987) proposed a software support environment developed to aid process engineering activities such as: synthesis of process flowsheets, configuration of control loops for complete plants, planning and scheduling of plant wide operation and operational analysis: it was named DESIGN-KIT. It is still under development.

## Intellite<sup>3</sup> DEVELOPMENTS

### 1. Overview of Intellite<sup>3</sup>

The **Intellite<sup>3</sup>** is a general purpose intelligent system, especially designed for supporting unified environments of control structure synthesis for complete chemical processing plants.

Based upon various control objectives, shortcut calculations, and several heuristics including control idioms, **Intellite<sup>3</sup>** interactively synthesizes the plausible control structures for a specified chemical processing plant (steady state process flowsheet to lead a specific P&I diagram) and effectively screens those alternatives to find most reasonable one in the context of overall plant control objectives, operability and other operational requirements.

Also it allows easy and transparent construction and manipulation of graphical engineering objects through active image, process models describing these objects, knowledge acquisition facility for the generation of heuristic and/or model based (rigorous) rules for an expert system. It was intended to support the needs of the new intelligent system which is necessary for the design of control systems for chemical plants and the educational aids for process engineers.

For effective representation of process knowledge and transparent goal setting for control system synthesis, **Intellite<sup>3</sup>** has a specially designed knowledge structure — the **Task Frame Net Model**. It's a model for deep knowledge representation consisting of a net-

work of Task Frames.

Each Task Frame has a specific goal. The goal is decomposed into a set of necessary and sufficient subgoals; the satisfaction of all subgoals guarantees the success of the root goal.

Based on the **Object Oriented Programming concept**, the Task Frame Net provides structured and systematic approach to overall goal — a reasonable plant-wide control system design. More detailed characteristics of the Task Frame Net are discussed in the later section.

Knowledge base structures are also logically structured in an object oriented manner. The "object oriented structure" of process knowledge representation makes it easy to trace processes with recycle streams; and it assures the consistency of the recommendations on the overall control structure to system users.

Currently **Intellite<sup>3</sup>** can configure 25 major processing units including binary distillation columns, several complex distillation columns, reactors, heat exchangers, compressors, furnaces, and several general types of columns, vessels, mixers and splitters. We can cover complex process flowsheets with these major processing units by assembling them and modifying pertinently with active images.

We can modify each unit with active images, which are kinds of interactive graphic objects that interact with parameters in knowledge base frames and the system user while consultation; active images have the ability of self modification and adaptation in the reasoning process.

Though the expert system mainly uses the symbolic manipulation, numerical computations are also indispensable in works like control structure synthesis. **Intellite<sup>3</sup>** has several built-in numerical routines for shortcut calculations including a RGA computation routine and an external steady state simulator for distillation columns. The computational results are associated with their parameters and used during reasoning processes or directly support his or her decisions on synthesis strategies.

Originally **Intellite<sup>3</sup>** was developed to meet the twin demands of education and practical implementation. Thus emphasis was placed both on ease of use and on incorporation of the most modern techniques.

Several neat graphical forms of process control loops are displayed and they are easily turned into screen hardcopies. The object oriented knowledge structures allows the students to easily organize their various knowledge and experiences on control structure synthesis for achieving the goal — designing complete control structure for the overall plant. Several

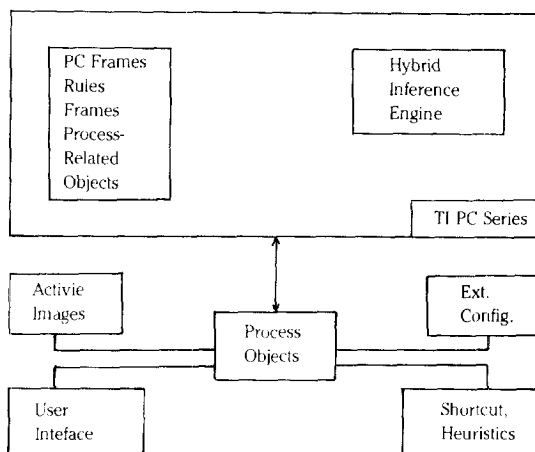

Fig. 1. Overall implementation structure of **Intellite<sup>3</sup>**.

heuristic recommendations on designing and controlling the processing units are also provided at the end of consultation. In the next section, we examine more detailed structural aspects of **Intellite<sup>3</sup>**.

## 2. Structural aspects of **Intellite<sup>3</sup>**

Up to now, we have explored the general overview of **Intellite<sup>3</sup>**. In this section, we can inquire into the detailed structure of **Intellite<sup>3</sup>**. Major divisions of **Intellite<sup>3</sup>** structure are **overall implementation**, **knowledge base**, and **roadmap to goal satisfaction**.

### 2-1. Overall implementation

The expert system, **Intellite<sup>3</sup>**, has been developed using **Texas Instrument's Personal Consultant Plus Series** (PC Plus, PC Image, and PC Online; announced at 1988 June, PC Plus version 4.0) and **PC Scheme** — a dialect of **LISP**. It runs under **IBM AT** (or AT compatible) computers with **protected memory mode** up to 4 mega bytes and a graphic support — **VGA card**.

Figure 1 shows the overall implementation of **Intellite<sup>3</sup>**. Frames, Parameters (object-attribute-value triplet form), and Variables in TI's PC Plus enable us to establish the structure in Figure 1.

As shown in Figure 1, process heuristics and deep knowledge, Task Frame Net and process related objects represented with parameters and variables are designed on **TI's PC Plus** main system. Using forward- and backward-chaining, versatile frame initiating strategies, the inference engine was designed as a **hybrid type**. Active images, shortcut calculation and heuristics routines, user interface and external configurator consist the modular structural environment and interact with process objects in **PC Plus'** knowl-

edge base.

**Active images**, supported in PC Image, are used for reasoning and tracing process parameter values and attributes; they provide effective representation of control idioms on the specified flowsheet with self addition, abstraction and modifications.

**Some shortcut calculation and heuristics routines** are programmed in PC Scheme to be built-in purpose on the PC Plus main system and others are programmed in external languages such as FORTRAN or C to be external numerical routines which interact with process objects through **XLI**, the external language interface facility in PC Plus.

**User interface module** consists of active input image screens and built-in pull-down-menu screens. System users can input some initial data for consultation which are either generated by the external steady state simulator or known values, e.g., column specifications for distillation column configuration. System users can choose the design strategy by selecting an appropriate path based on plant wide control objectives through active images. The built-in pull-down-menu provides various reasoning statuses to the system user through the options: **HOW, WHY, TRACE, REVIEW, GET PLAYBACK FILE, SAVE PLAYBACK FILE, PRINT CONCLUSIONS, NEW START, QUIT, CONTINUE**, and etc.

## 2-2. Knowledge base structure

The knowledge base of **Intellite<sup>3</sup>** adopts hierarchical structures. Thus, hierarchical and multiple inheritance of process objects (through parameters and their properties), and structured design of process knowledge base are available. Undoubtedly any initiation or inheritance of parameters across the whole knowledge base is also available using **variables** in PC Plus.

Current version of **Intellite<sup>3</sup>** has **25 major processing units as child frames** in the **PROCESS** frame. In addition to them, frame **MAIN** (root frame) and frame **START** for specifying process flowsheet and frame **STREAM\_LAYOUT** consist the overall knowledge base. Figure 2 shows the overall knowledge base structure of **Intellite<sup>3</sup>**.

Logical (and numerical) methods and several heuristics (and control idioms) existing in the knowledge base are widely used for process control design.

The difficulties in determining the suitable pair of manipulated and controlled variable grow exponentially as the number of process variables increases. For a system with  $N$  controlled and  $N$  manipulated variables, there are  $N!$  different fully decentralized loop configurations. As the number of  $N$  increases, the number of different loop configurations increases very

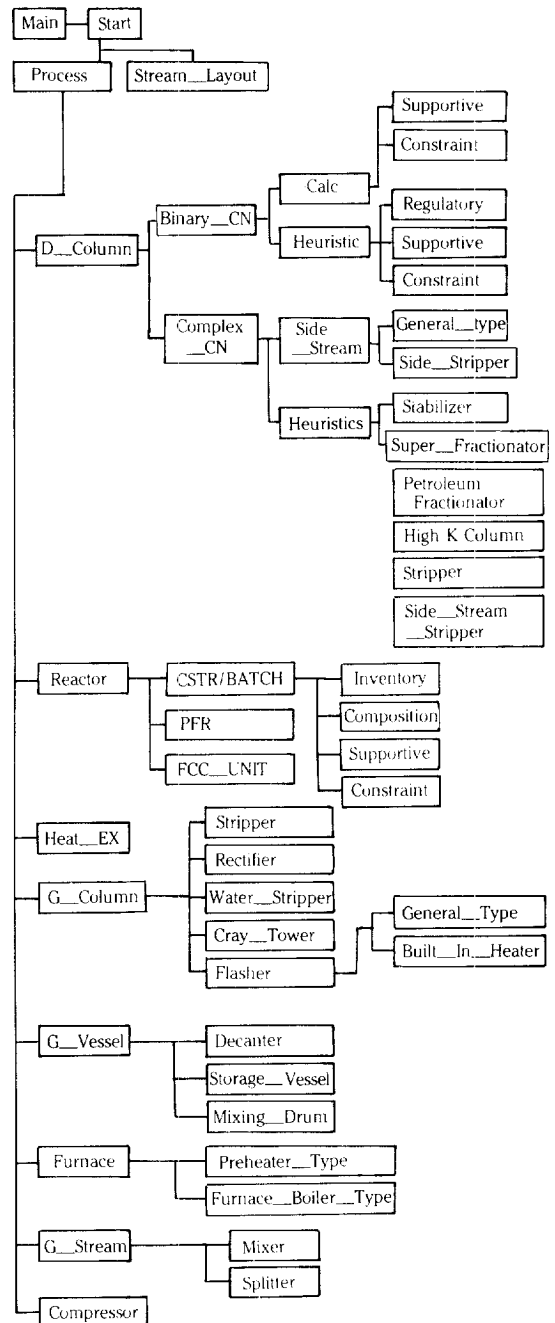

Fig. 2. Knowledge base structure of **Intellite<sup>3</sup>**.

rapidly; often they cause the combinatorial explosion. Thus variable pairing in control system design is also very structured in nature. The selection of variable pairing is usually accomplished by using some interaction measures as well as some heuristic rules at the ini-

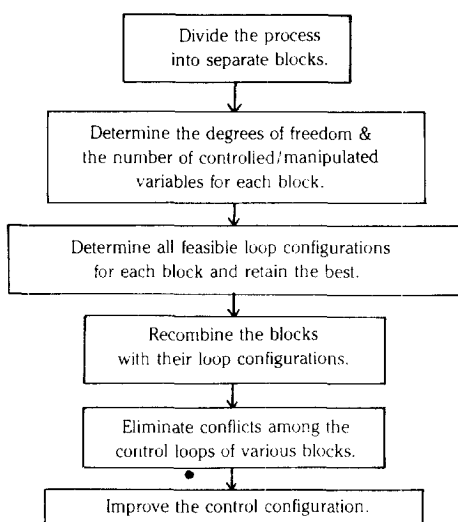

Fig. 3. Multi-level approach to control system synthesis.

tial stage of process design. For example, in configuring control structure for binary distillation columns, the user can select the pairing methods: pairing **by calculation** (steady state simulation and F.G. Shinsky's computed RGA criterion; Shinsky, 1984) or pairing **by control objectives and heuristics**. Additional options for pairing methods like Page Buckley's criterion (Buckley P.S., W.L. Luyben, and J.P. Shunta, 1985), frequency-dependent RGA analysis proposed by S. Skogestad (Skogestad S. et al., 1989), and etc. can be included in *Intellite*<sup>3</sup>. We feel that for the more precise and proper pairing, more demands are being placed on the dynamic simulation of the process under consideration.

### 2-3. Roadmap to goal satisfaction

Our final goal is to find a reasonable control structure for a process flowsheet. There are many alternatives that often form a combinatorial search space. To effectively screen those alternatives and find reasonable one fast, we adopt the multi-level approach first proposed by Umeda et al. (Umeda et al., 1978) and refined by Stephanopoulos (Stephanopoulos G., 1984). Figure 3 shows such a multi-level approach and Figure 4 represents a "Roadmap" to goal satisfaction in *Intellite*<sup>3</sup>.

In Figure 4, the large block at the top of the figure represents the conceptual Task Frame Net which is discussed in the next section. The overall goal is to find a reasonable control structure of the proposed plant. Each unit frame generally has four child task frames: regulatory-control frame; supportive-control frame; constraint-control frame; and conflict resolu-

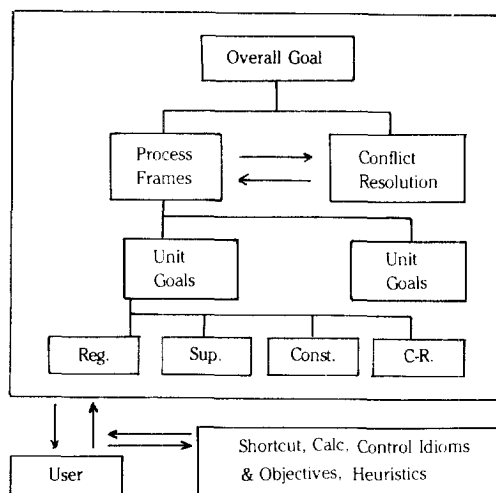

Fig. 4. Roadmap to the goals of *Intellite*<sup>3</sup>.

tion frame. This Task Frame Net interacts with user interface module and another module consisting of shortcut calculations, control idioms, control objectives, and heuristics.

## 3. Task Frame Net Model

### 3-1. Divide and conquer!

This is a prevalent heuristic in our daily life. If we have a certain problem too large to handle at a time, we naturally decompose it into several smaller and more understandable parts; we find sub solutions and then recombine them. This kind of intellectual behavior is unique to humans and some other intelligent animals. In artificial intelligence, we characterize creative behaviors as: representation (abstraction), inference (reasoning), search (control of combinatorial explosion), indexing (knowledge retrieval), prediction & recovery (adaptation), dynamic modification (self organization), and generalization (learning).

In process control and synthesis fields, there are several examples of solving problems by decomposition and recombination procedure (Douglas J.M., 1985; Modarres M. et al., 1986; Fusillo R.H. et al., 1987; Lakshmanan R. et al. 1988a, 1988b; etc.).

The **Task Frame Net model** developed in *Intellite*<sup>3</sup> project is a hierarchical knowledge representation scheme for representing deep knowledge. The root frame of the Task Frame Net has the overall goal: finding a reasonable control structure over a complete plant. Each of the frame in the network represents sub goals (usually one or more) to be satisfied at each step in each level of whole configurational working process. Similar to a goal-driven strategy in the inference process, each Task Frame set its subgoals; the satisfac-

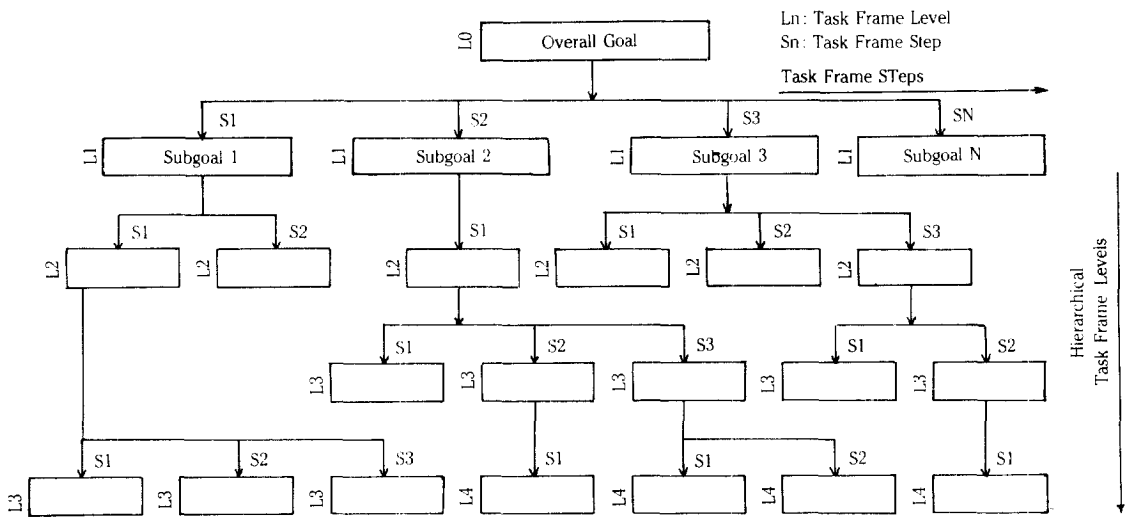

Fig. 5. Structure of Task Frame Net.

tion of all subgoals ensures the satisfaction of the root goal.

The **Task Frame Levels** are aligned vertically with hierarchy of specific control structure design goals and **Task Frame Steps** are aligned horizontally in a level of each hierarchical task. The vertical path, i.e., **Task Frame Levels**, provides the method how each subgoal is satisfied and usually terminates with actual implementation of each actuator to each manipulated variable. Thus for the lowest goal setting, there exist several alternatives and we can handle them as pairing problems. **Task Frame Steps** in each level provide necessary conditions for satisfying their parent Frame's goal.

This separate goal setting on each Task Frame is largely due to Bristol's idiomatic control methodology. Idiomatic control analysis is an attempt for structural analysis and synthesis of control systems. Since idiomatic control synthesis is a structured procedure in which control objectives or goals are unambiguously defined, it is highly likely that a knowledge representation for the structured knowledge exists.

Unit goals of a processing unit are generally decomposed into subtasks: regulatory, supportive, and constraint control tasks. In the Task Frame Net model, the goals are determined according to their priorities, i.e., regulatory first, then constraint second, and finally supportive. Some conflicting situations can occur when certain constraints are imposed on the process under consideration. Conflicts generally exist between regulatory controls and constraint controls or in the regulatory controls themselves. In the former case, we can handle it with some advanced control schemes

like selective control systems (override and auctioneering) or split-range controls (with coordinate control scheme). The latter situation requires some (economic) trade-offs between conflicted goals. In the case of distillation columns and reactors, we generally give higher priority to inventory controls than to composition controls. The composition controls must be sacrificed when constraints are imposed on inventory controls. Figure 5 shows general structure of the Task Frame Net.

The Task Frame Net model is also convenient for establishing whole knowledge bases with object oriented structure. It clarifies what goals should be satisfied and how can we achieve them to satisfy our final goal. Thus the Task Frame Net clearly reveals the overall knowledge structure and provides transparent reasoning path during consultation.

### 3-2. Constructing the Task Frame Net

To describe the construction of the **Task Frame Net** we will use the sample Task Frame Net taken from binary distillation column knowledge bases in **Intellite<sup>3</sup>**. Figure 6 shows the Task Frame Net structure of binary distillation column in **Intellite<sup>3</sup>**.

The main goal of the root frame in Task Frame Net is to find reasonable control configurations for a given distillation column. This root Task Frame is divided into three sub Task Frames: determining regulatory controls, constraint controls, and supportive controls. As shown in Figure 6, the regulatory control Frame is broken into sub Task Frames again to satisfy each necessary goals such as composition controls and inventory controls which guarantee the successful satisfaction of regulatory Task Frame goals. The Task

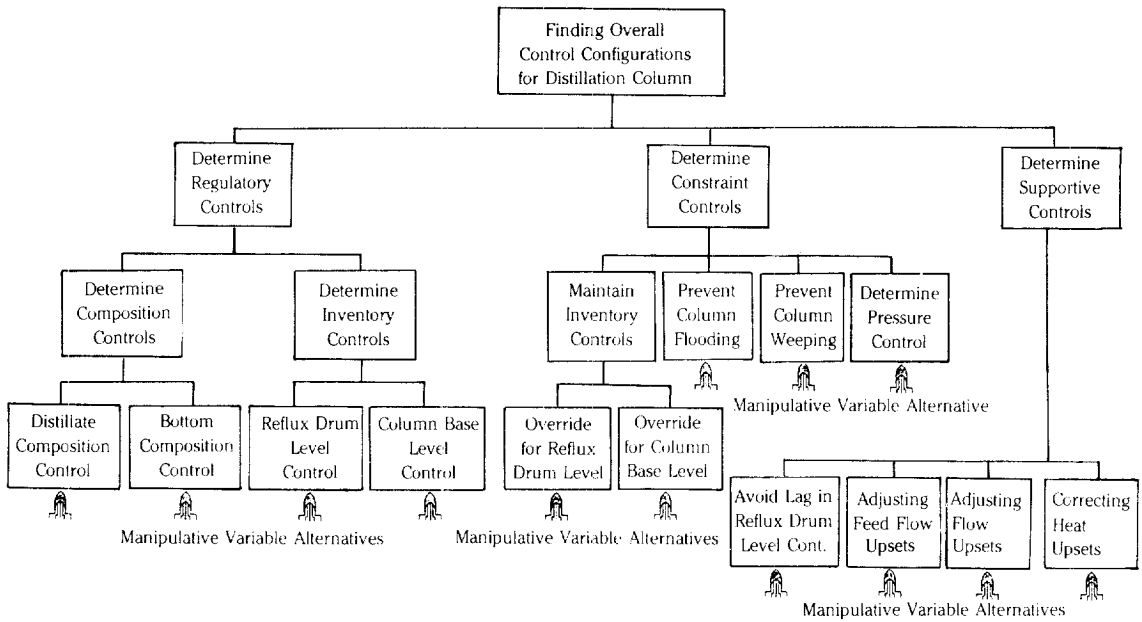

Fig. 6. Task Frame Net of distillation column.

Frames of composition and inventory controls are decomposed in a similar way to the lowest Task Frame which finds specific manipulative variables. Thus, the lowest Frame of each Task Frame, i.e., the end node of each Task Frame Level, generally has several competing alternatives of manipulative variables.

The manipulative variable alternatives for distillate composition control are the reflux flow  $L$ , distillate flow  $D$ , or reflux ratio  $L/D$ ; and those for bottom composition control are the bottom flow  $B$ , steam input  $V$ , or the ratios  $V/B$  or  $L/B$ , etc.

The pairing problem (assigning one of those variables to each goal, i.e., the controlled variable, of the lowest Task Frame) is resolved either by shortcut calculations (e.g., RGA computation) or by direct pairing based on several heuristics.

Once **Intellite**<sup>3</sup> finds the pairings of composition controls, then it determines inventory control pairings automatically based on heuristics.

Constraint controls are those which take over control of the process when it approaches the limits of normal operation. These controls are often process specific, such as controlling the vapor rate in a distillation column between the flooding and weeping constraints. We can easily take up these constraint goals by combining standard process idioms with control objectives of each operation. Subgoals of the constraint controls are determining overrides for level control at constraint, overrides to avoid flooding and weeping, and

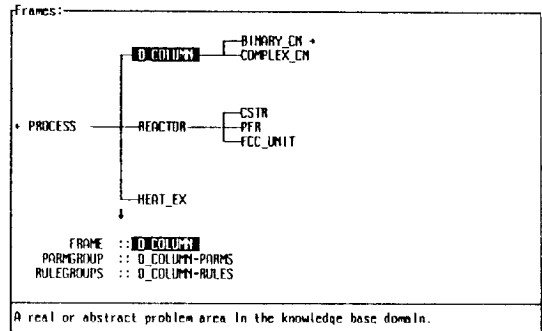

Fig. 7. Task Frame Net structure of process in KB.

overrides to control column pressure.

In many processes, the regulatory and constraint controls can be improved by using some supportive controls such as cascade, feedforward, etc. Task Frames of supportive controls are decomposed into sub Task Frames: feedforward control to reduce lag in reflux drum level response, feedforward control compensating feed flow changes, cascade control to reduce the effects of heat upsets and flow upsets.

Each process in **Intellite**<sup>3</sup> has certain Task Frame Nets similar to those of distillation column mentioned above. But, there are some processes that do not require complex Task Frames in configuring their control structures. They are rather simple processing units such as Stream-Mixer or Stream-Splitter, Heat-Ex-

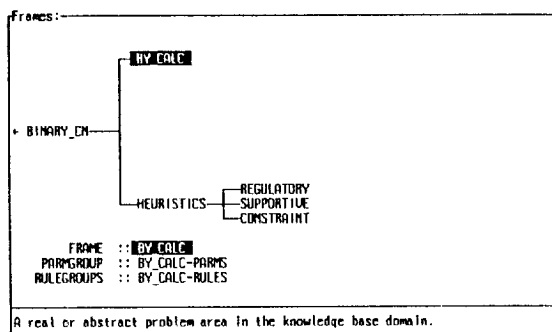

Fig. 8. Task Frame Net structure of binary\_CN in KB.

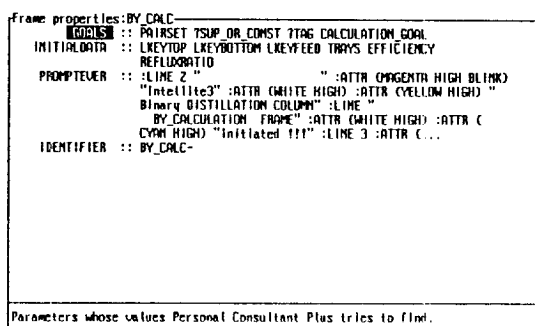

Fig. 9. Task Frame properties of BY\_CALC.

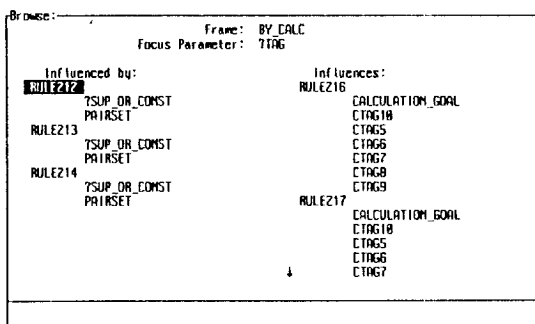

Fig. 10. Task Frame parameter browser of BY\_CALC.

changer, etc. In this work, control configurations of those units were done by intuitive and careful observations on the several existing process flowsheets.

Figures 7-10 show the Task Frame Net structures, their properties and parameter browser.

### WORKING EXAMPLE OF Intellite<sup>3</sup>

#### 1. Distillation column control

Figures 11-24 show how Intellite<sup>3</sup> is used to design binary distillation column controls. Here, we

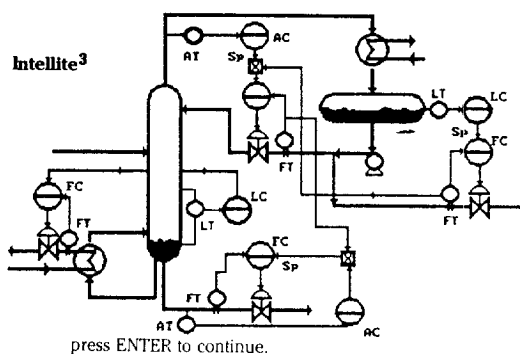

Fig. 11. Intellite<sup>3</sup> initial title screen 1.

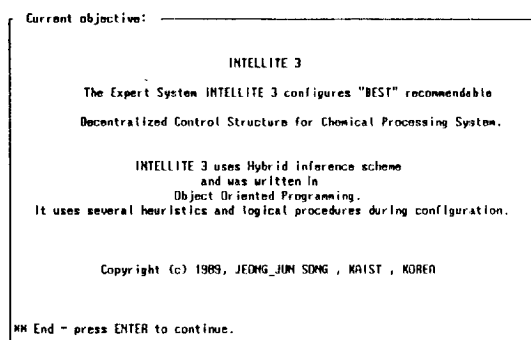

Fig. 12. Intellite<sup>3</sup> initial title screen 2.

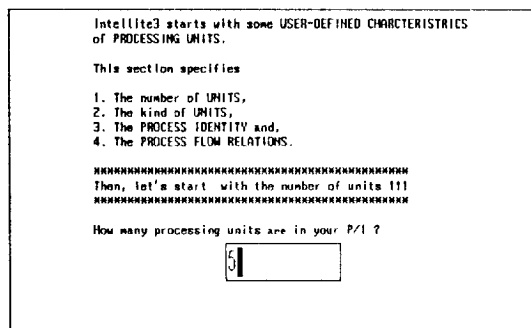

Fig. 13. Inputting the number of units.

can use two methods for variable pairing: (1) RGA method and (2) direct pairing based on the control heuristics.

In the former case, we need some initial data for column specifications such as product quality specs, feed composition, number of trays, column efficiency, and reflux ratio. These numerical data can be acquired from steady state simulations or from process descriptions.

Expert systems can maximize the utilization of the existing available informations, that is, the results from

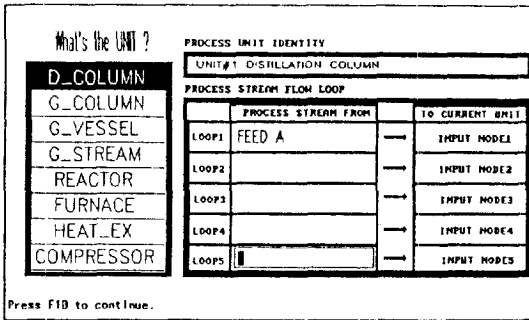

Fig. 14. Unit & stream specification.

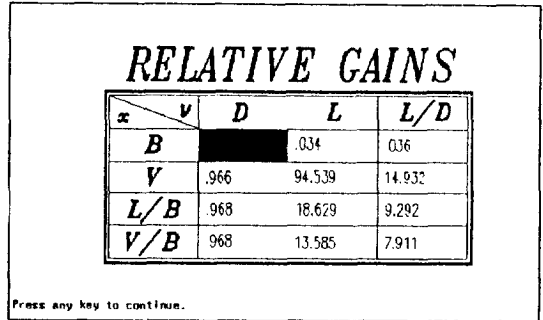

Fig. 18. Computed RGA.

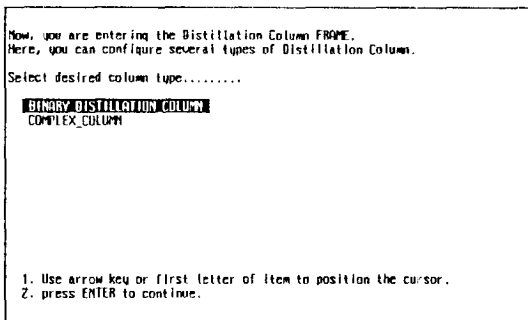

Fig. 15. Selecting distillation column type.

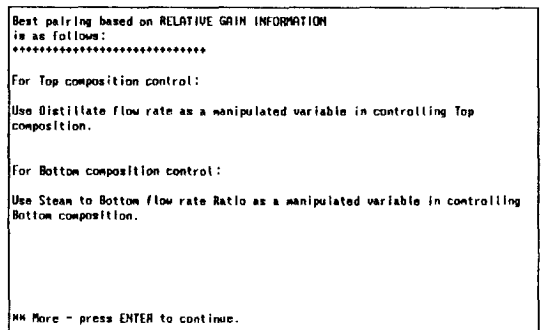

Fig. 19. Pairing recommendation based on RGA.

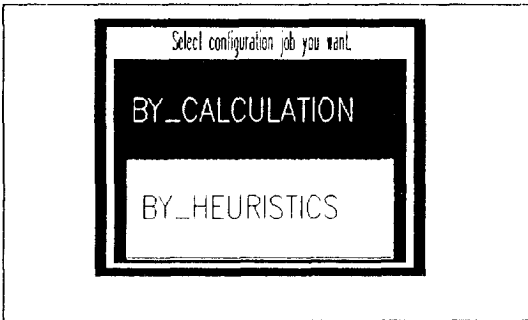

Fig. 16. Pairing method selection.

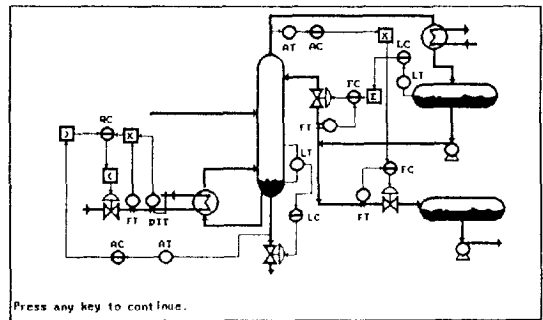

Fig. 20. Regulatory controls.

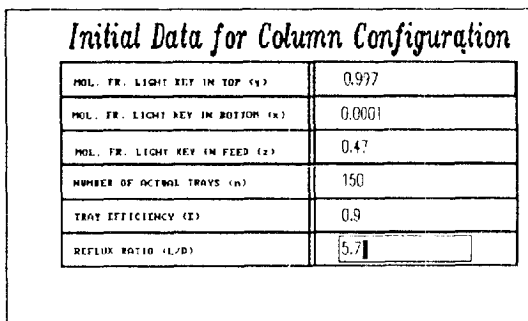

Fig. 17. Distillation column spec.

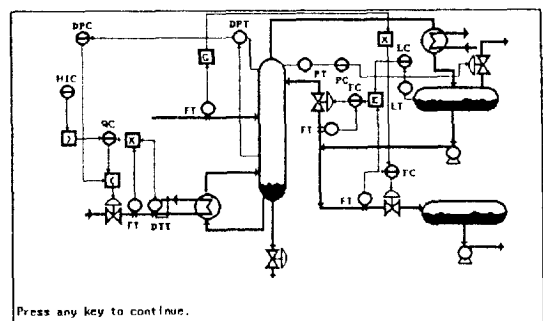

Fig. 21. Constraint & supportive controls.

that the level in the column base and reflux accumulator are always under control even during constraint operation.

- x For Top Composition Control, use Distillate Flow Rate as a manipulated variable.
- x To control Bottom composition, use boilup to bottom ratio as a manipulated variable.
- x To control top Drum level, use the reflux flow rate as a manipulated variable.
- x To control column base level, use bottom product flow rates as a manipulated variable.

2. Supportive Control loops are :

\*\* More - press ENTER to continue.

Fig. 22. Recommendations on regulatory controls.

The basic regulatory and constraint controls can be improved by using some supportive control loops.

Determination of the supportive controls for improved performance includes use of CASCADE and FEEDFORWARD control loops.

The appropriate use of these supportive or secondary control schemes is determined largely by HEURISTICS or ( RULES OF THUMB ).

One common supportive control loop is the flow control loop used as the inner loop of a cascade arrangement for a slower loop such as composition.

The purpose of a flow loop is to increase performance of the outer loop by rejecting disturbance in the inner loop. The flow loop can compensate very quickly for upsets in flow due to pressure changes.

- x To remove lag in the response of top drum level control, build cascade control loops using flow rates of reflux and distillate stream.

\*\* More - press ENTER to continue.

Fig. 23. Recommendations on supportive controls.

the systems can be degraded gradually from the excellent results when all information such as steady state information, steady/dynamic models, heuristics are available, to the acceptable results when the only source of knowledge is heuristics based on the process design. The direct pairing method based on control heuristics may give only acceptable result. We feel that the results from both pairing methods should be tested by rigorous dynamic simulation before we can know if they are really good.

## CONCLUSIONS

An expert system for designing control structures for distillation columns have been implemented and useful techniques on building industrially usable expert systems for other application fields have been obtained.

The expert system, Intellite<sup>3</sup>, for control structure synthesis on chemical processing plant can serve as a useful aid to process engineers, plant operators and as an effective educational aid to students who search for this area and who are willing to organize his or her idea into knowledge based expert systems.

The **Task Frame Net model** was fully used as a basic backbone of the knowledge representation

Safe operation at constraints is satisfied by the following goals :

- x To prevent flooding in column, use pressure difference as an indicator and build override control with BTU controller.

Flooding can occur if column throughput is increased resulting in a higher volume of vapor boilup.

The high vapor rate can cause liquid backup on the trays as the vapor attempts to flow through downcomers. Flooding can be avoided by limiting the heat input to values below the flooding point.

Pressure drop across the column is normally used as a measure of approach to flooding. As flooding is approached, the pressure drop across the column increases dramatically.

The control loop implementation is as follows :

Using a differential pressure controller to override the heat input to the

\*\* More - press ENTER to continue.

Fig. 24. Recommendations on constraint controls.

scheme in the expert system. The **Object Oriented Programming** is implemented on Task Frame Net model using Frames and idiomatic control methodology. Due to the Task Frame Net, the whole knowledge structure is clearly organized and the system user can "grab fast" the functional objects, goals, and reasoning processes.

The major features of Intellite<sup>3</sup> are as follows:

1. It can configure control systems for binary distillation columns based on either by the RGA method or by direct pairing based on control objectives.
2. It has highly modular structures with object oriented programming on the Task Frame Net.
3. Well structured knowledge bases reveal transparent reasoning process and provide refined explanation to the user through several user friendly interfaces.

4. Current version of Intellite<sup>3</sup> has open structure for further expansions. Intellite<sup>3</sup> will continue to be improved and supported by additional works. We are currently expanding it to configure control system for whole chemical processing plants and planning the extensions of the system like dynamic simulation facility, active animation of overall process flowsheets, and more precise and logical interaction measures.

Automating the design of plant wide control system is a project operating in multiple phases with a series of knowledge intensive tasks.

The basic scope of the methodology, established by expert systems, is complemented and enlarged by techniques from knowledge based expert systems and rigorous analytical tools offered by the advanced control theory. Thus the performance of resulting expert system is very close to the quality of gathered process knowledge and its structure.

To achieve the final goal of knowledge based expert systems for control structure synthesis and for other fields such as process synthesis, fault diagnosis, and online intelligent controls, it is important to

expand the framework of the research area and to stimulate research in new areas.

Basic and renewed analysis of problems and problem solving methods in control structure synthesis and whole process engineering are required to establish a new paradigm leading to useful expert system development. **Eventually through these processes, the resulting expert systems can provide more convenient and safe working environments for human beings!**

#### REFERENCES

1. Arkun, Y. and Stephanopoulos, G.: Studies in the Synthesis of Control Structures for Chemical Processes: Part IV: Design of Steady-State Optimizing Control Structures for Chemical Process Units, *AIChE J.*, **26**(6), 975 (1980).
2. Arkun, Y. and Stephanopoulos, G.: Studies in the Synthesis of Control Structures for Chemical Processes: Part V: Design of Steady-State Optimizing Control Structures for Integrated Chemical Plants, *AIChE J.*, **27**(5), 779 (1981).
3. Birky, G.J., McAvoy, T.J. and Modarres, M.: An Expert System for Distillation Control Design, *Computers & Chemical Engineering*, **12**(9,10), 1045 (1988).
4. Birky, G.J., McAvoy, T.J. and Tyreus, B.: DI-CODE—An Expert System for Designing Distillation Column Controls, *Proc. American Control Conference*, June 21-23, 1989, Vol. 1, PP. 95-100.
5. Bristol, E.H.: After DDC: Idiomatic Control. CEP November, pp. 84-89 (1980).
6. Buckeley, P.S., Luyben, W.L. and Shunta, J.P.: Design of Distillation Column Control Systems, *Instrument Society of America*, 1985.
7. Douglas, J.M.: A Hierarchical Design Procedure for Process Synthesis, *AIChE J.*, **31**(3), 353 (1985).
8. Douglas, J.M.: *Conceptual Design of Chemical Processes*, McGraw-Hill International, 1988.
9. Fisher, W.R., Doherty, M.F. and Douglas, J.M.: The Interface between Design and Control. 1. Process Controllability, *Ind. Eng. Chem. Res.*, **27**, 597 (1988a).
10. Fisher, W.R., Doherty, M.F. and Douglas, J.M.: The Interface between Design and Control. 2. Process Operability, *Ind. Eng. Chem. Res.*, **27**, 606 (1988b).
11. Fisher, W.R., Doherty, M.F. and Douglas, J.M.: The Interface between Design and Control. 3. Selecting a Set of Controlled Variables, *Ind. Eng. Chem. Res.*, **27**, 611 (1988c).
12. Fusillo, R.H. and Powers, G.J.: A Synthesis Method for Chemical Plant Operating Procedures, *Computers & Chemical Engineering*, **11**(4), 369 (1987).
13. Govind, R. and Powers, G.J.: Synthesis of Process Control Systems, *IEEE Transaction on SYSTEMS, MAN, AND CYBERNETICS*, Vol. SCM-8, No. 11, November, pp. 792-795 (1978).
14. Govind, R. and Powers, G.J.: Control System Synthesis Strategies, *AIChE J.*, **28**(1), 60 (1982).
15. Lakshmanan, R. and Stephanopoulos, G.: Synthesis of Operating Procedures for Complete Chemical Plants—I. Hierarchical Structured Modeling for Nonlinear Planning, *Computers & Chemical Engineering*, **12**(9,10), 982 (1988a).
16. Lakshmanan, R. and Stephanopoulos, G.: Synthesis of Operating Procedures for Complete Chemical Plants—II. A Nonlinear Planning Methodology, *Computers & Chemical Engineering*, **12** (9,10), 1003 (1988b).
17. Modarres, M. and Cadman, T.: A Method of Alarm System Analysis for Process Plants, *Computers & Chemical Engineering*, **10**(6), 557 (1986).
18. Morari, M., Arkun, Y. and Stephanopoulos, G.: Studies in the Synthesis of Control Structures for Chemical Processes: Part I: Formulation of the Problem, Process Decomposition and the Classification of the Control Tasks, Analysis of the Optimizing Control Structures, *AIChE J.*, **26**(2), 220 (1980a).
19. Morari, M. and Stephanopoulos, G.: Studies in the Synthesis of Control Structures for Chemical Processes: Part II: Structural Aspects and the Synthesis of Alternative Feasible Control Schemes, *AIChE J.*, **26**(2), 232 (1980b).
20. Morari, M. and Stephanopoulos, G.: Studies in the Synthesis of Control Structures for Chemical Processes: Part III: Optimal Selection of Secondary Measurements within the Framework of State Estimation in the Presence of Persistent Unknown Disturbances, *AIChE J.*, **26**(2), 247 (1980c).
21. Niida, K. and Umeda, T.: Process Control System Synthesis by an Expert System, *Proc. Third Int. Conf. Chem. Process Control*, Asilomar, Calif., January 12-17, 1986; *CHEMICAL PROCESS CONTROL-CPC III*. ELSEVIER, pp. 869-894.
22. Shinskey, F.G.: *Distillation Control for Productivity and Energy Conservation*, 2nd. ed., McGraw-Hill, 1984.
23. Shinskey, F.G.: An Expert System for the Design of Distillation Controls, *Proc. Third Int. Conf. Chem. Process Control*, Asilomar, Calif., January 12-17, 1986; *CHEMICAL PROCESS CONTROL-CPC III*, ELSEVIER, pp. 895-912 (1986).

24. Skogestad, S., Jacobensen, E.W. and Lundstrom, P.: Selecting the Best Distillation Control Structure, IFAC Sym., DYCORD+ '89, August 21-23, 1989, Maastricht, The Netherlands, pp. 295-302.
25. Song, J.J. and Park S.W.: **Intellite<sup>3</sup>**: An Expert System for Control Structure Synthesis, *Res. Paper Abstract (Autumn), KICChE*, 1989.
26. Song, J.J.: **Intellite<sup>3</sup>**: An Expert System for Control Structure Synthesis, MS Thesis, KAIST, 1990.
27. Stephanopoulos, G.: Synthesis of Control Systems for Chemical Plants-A Challenge for Creativity-, *Computers & Chemical Engineering*, **7**(4), 331 (1983).
28. Stephanopoulos, G.: Chemical Process Control, Prentice-Hall, Inc., 1984.
29. Stephanopoulos, G., Johnston, J., Kriticos, T., Lakshmanan, R., Mavrovouniotis, M. and Siletti, C.: DESIGN-KIT: An Object-Oriented Environment for Process Engineering, *Computers & Chemical Engineering*, **11**(6), 655 (1987).
30. Umeda, T., Kuriyama, T. and Ichikawa, A.: A Logical Structure for Process Control System Synthesis, Proc. IFAC Cong., Helsinki, 271 (1978).