

Multi-layered nonwoven filter media for capture of nanoparticles in HVAC systems

Naim Hasolli, Young-Ok Park, and Kwang-Deuk Kim[†]

Korea Institute of Energy Research, Daejeon 34129, Korea

(Received 2 November 2020 • Revised 25 February 2021 • Accepted 26 February 2021)

Abstract—Two samples of multi-layered depth filter media and single layers were prepared for this study. Filtration performance of these samples was evaluated using lab scale test unit with KCl as test aerosol. Filter media samples were composed of three layers, two of them of meltblown fiber layers and one of thermal-bonded microfiber layer. A commercial filter media was used as reference sample to compare the filtration performance. Quality factors were calculated in addition to evaluate the overall filtration performance of the new composite filter media. The results indicate a satisfactory filtration efficiency of the media M2U, over 90% for the studied particle size range. Compared to reference media, new media M2U shows better performance, especially for the particle size greater than 50 nm. Charged (M2U) and uncharged (M2U-2) composite media were tested and results compared with theory calculations. Due to upstream layer of high packing density, the loading tests reveal a tendency of clogging for media M2U. Both media, M1U and M2U, exhibit better filtration performance compared to the reference media RefM and could be applied for collection of nanoparticles in HVAC system by replacing the high grade efficiency filters.

Keywords: Nanoparticle, Composite Filter Media, Clogging, Pressure Drop, Fractional Efficiency

INTRODUCTION

With accelerated development of nanotechnology, the collection, control and removal of nanoparticles has become an increasingly critical issue. Issues and implications due to nanoparticle production are discussed in detail in [1]. Risk of exposure to engineered and airborne nanoparticles is discussed in [2,3]. Especially in nanoparticle laboratories, where the concentration of nanoparticles is high, efforts are made to bring the contamination under control and make the lab safe for the staff. Air ventilation in these rooms is therefore of crucial importance. Heating, ventilation, air-conditioning and cooling systems (HVAC) are generally equipped with one or more filter stages. Fine filter grades are required for separation of fine particles from air stream. Generally, these high efficiency filters are made of synthetic fibers and can reach high efficiency particulate arrestance (HEPA) grades. Filter media for these applications are made of thin layer with high fiber packing density backed by a supporting layer. High packing density and small fiber diameter mean that the interstitial space between packed fibers is small and the air permeability is consequently low. This is the main reason for filter media high pressure drop. High collection efficiency is usually coupled with high pressure drop. A composite nonwoven media, made of a number of layers, would be a solution to the problem [4]. By combining various layers in a single media, optimal parameters can be achieved. With proper combination of high fiber density layers and large fiber layers, it is possible to achieve two different filtration mechanisms, surface and depth filtration, depending on the arrangement of the high efficiency layer. If a thick supporting layer is placed upstream of a thin fine fiber layer, the particles

will be deposited inside the supporting layer. This type is called depth filtration. If the fine fiber layer is placed upstream and the supporting layer is attached downstream, then the particles will be collected on the surface of the fine fiber layer. This type is called surface filtration [6,7]. That means, if effective particle collection is required, independent of the filtration mechanism, surface or depth filtration, the application of fine fiber layer is inevitable. Another method to avoid using a fine fiber layer is to enhance the performance of a less efficient media by applying electrostatic charge [5]. According to Frederick [5], the charging of the media by high voltage can improve the filtration performance, reduce the pressure drop and affect the particle collection on the surface and inside the filter media layer. Charge decay due to dust loading, improper storage and handling are just few of the issues concerning this method. To prevent the electrostatic charge form decay, and eventually its complete loss, in some applications an external electrical field is applied. Such systems apply charge electrodes upstream and downstream of the filter element. In case of high particle loading, the charge will be decreased as the particles cover the fiber surface by neutralizing the fiber charge and eventually make the charge ineffective.

A new method is suggested in this study by combining three different layers into two new filter media samples. Two fine fiber layers, MB_2 and MB_5, were manufactured using the meltblown process by applying corona charging. Supporting layer, TB, is manufactured using thermalbonding. By applying heat the large diameter fibers melt slightly on the surface, thus creating a fixed fiber web. These three layers are combined in two different arrangements by laminating the layers into a composite filter media. Two media were tested to evaluate their filtration performance. Single layers were tested to determine their role in the composite media. A lab-scale test unit was utilized with KCl, as test aerosol, and scanning mobility particle sizer (SMPS), as measuring apparatus, to evalu-

[†]To whom correspondence should be addressed.

E-mail: kdkim@kier.re.kr

Copyright by The Korean Institute of Chemical Engineers.

ate the fractional collection efficiency and particle loading effect on the filtration performance. In addition, quality factor was calculated from filtration efficiency and pressure drop data as function of face velocity and compared with reference media. A proper combination of different layers would allow a filtration process where fine particles are captured with high efficiency at low pressure drop.

EXPERIMENTAL SECTION

1. Experimental Set-up and Test Procedure

Dry high pressurized air (1) was applied for generation of solid KCl particles inside the atomizer (2). A diffusion dryer (3) was applied. Particle charge was removed while passing the air through neutralizer (4). Circular flat filter samples (5) of the effective diameter 42mm were cut and placed between two clamps with rubber gaskets which hold the filter sample air-tight. Pressure drop transmitter (6) was connected to up- and downstream ports for continuous record of the pressure drop values. Particle concentration measuring ports were also placed upstream and downstream of the filter sample and connected to a spectrometer (7) from where the data were further processed using a personal computer (8) as displayed in the Fig. 1. These two ports were connected alternately to measure the up- and downstream particle concentration. The time difference between two measurement runs was 6 minutes. Time duration for one complete run with measurement of inlet and outlet particle concentration was 12 minutes. The entire range of particles (measured by the unit SMPS, TSI, model 3936) was between 10 and 700 nm. Air flow was regulated through the control unit which included vacuum pump (11), Mass Flow Controller (MFC) (9) and the control unit (10). Absolute filter (12) was installed to prevent particles from contaminating the lab space.

2. Filtration Performance Evaluation Method

Initial filtration performance of the filter media and that of single layers was evaluated using standard test units. Air permeability was measured at the pressure of 125 Pa using the air permeability tester TEXTEST (model FX3300). Initial pressure drop, and initial particle collection efficiency were measured using the automated filter tester TSI (model 8130) with NaCl as testing particles. The specifications are summarized in the Table 1.

Lab scale filter test unit was prepared for the purpose of evaluating the filtration performance as function of the test parameters. Flow rate was varied between 2.9 and 11.6 L/min. During the pressure drop tests, clean filter media and single layer samples were examined without injection of test particles, and the pressure drop values were recorded continuously.

Particle collection efficiency was evaluated by injecting the KCl

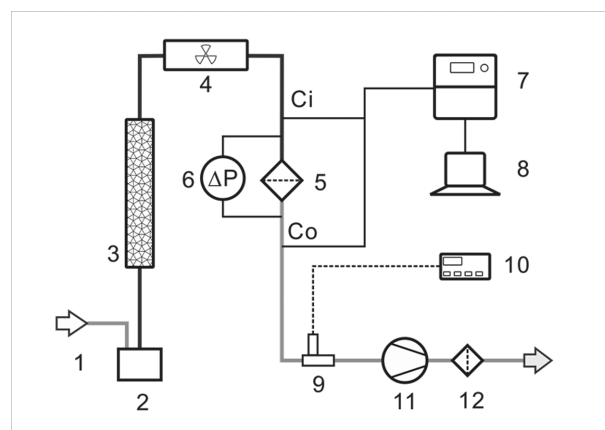

Fig. 1. Experimental set-up with essential functional units.

particles at constant rate and measuring their concentration upstream (C_i) and downstream (C_o) the filter samples. After the tests, the recorded data were processed to find out the particle collection efficiency using the following equation

$$E = \frac{C_i - C_o}{C_o} \times 100 \quad (1)$$

Particle loading test was conducted by fixing the flow rate and the particle injection rate. The samples of media M1U, M2U and reference media RefM were tested with this method. The particles were injected into the system for 60 minutes and the particle concentration was measured continuously, by switching alternatively upstream and downstream of the filter media. Pressure drop data were recorded simultaneously with the particle measurements.

In addition to experimental study, theoretical calculations were performed using the well-established calculation method. These calculations are usually performed to predict the initial filtration performance. These calculations represent a set of empirical equations developed by various research studies. Filtration efficiency (η) is calculated by using the expression:

$$\eta = 1 - \exp\left(\frac{-4\alpha Et}{\pi d_f(1-\alpha)}\right) \quad (2)$$

where E is the single fiber collection efficiency, t is the thickness of filter media; d_f is the fiber diameter and α is the solidity of filter. Single fiber efficiency is a sum of efficiency due to Brownian diffusion (E_D), interception (E_R), impaction (E_I) and the gravity (E_G). Empirical equations and the mechanisms are described in detail in

Table 1. Properties of the composite filter media layers

| Properties and single layers | | MB-5 | MB-2 | TB |
|--|---------------------------------------|-------|------|-------|
| Specific weight | [g/m ²] | 14 | 10 | 70 |
| Thickness | [mm] | 0.17 | 0.07 | 0.3 |
| Air permeability (At 125 Pa and sample size 20 cm ²) | [m ³ /m ² /min] | 106.7 | 47.8 | 213.4 |
| Initial pressure drop (3.2 m/min and sample size 100 cm ²) | [Pa] | 0.4 | 1.0 | - |
| Initial efficiency (Challenged with NaCl particles) | [%] | 60 | 97 | - |

[5-8]. For the particle range of the interest in this study, only diffusion and interception are considered. Single fiber efficiency due to Brownian diffusion is a function of Peclet number defined as

$$Pe = \frac{d_f U}{D} \tag{3}$$

where d_f is the fiber diameter, U is the aerosol approaching velocity and D is the diffusion coefficient. Diffusion coefficient is inversely proportional to particle diameter (d_p) and is expressed as

$$D = \frac{K_b T C_C}{3 \pi \mu d_p} \tag{4}$$

where K_b is the Boltzmann constant, T is the temperature, μ is the air viscosity and C_C is the Cunningham slip correction factor. The single fiber efficiency due to Brownian diffusion [9] is expressed as in the equation below

$$E_D = 0.86 Pe^{-0.43} \tag{5}$$

Single fiber efficiency due to interception is suggested by authors Lee and Liu [10] and is expressed as

$$E_R = \left(\frac{1-\alpha}{Ku} \right) \frac{R^2}{1+R} \tag{6}$$

where R is the interception parameter and Ku is the Kuwabara hydrodynamic factor. Interception parameter R is expressed as

$$R = \frac{d_p}{d_f} \tag{7}$$

Kuwabara hydrodynamic factor is expressed as function of solidity factor α

$$Ku = d - 0.5 \ln \alpha - 0.75 - 0.25 \alpha^2 + \alpha \tag{8}$$

Pressure drop is defined as the resistance of the filter media to air flow. According to Lee and Mukund [11], theoretical pressure drop (ΔP_{th}) is expressed as

$$\Delta P_{th} = \frac{16 \mu \alpha U t}{Ku d_f^2} \tag{9}$$

For filter media composed of layers with different fiber diameter, it is necessary to define the effective fiber diameter, D_{fd} . The expression for calculation of the effective fiber diameter is

$$D_{fd} = 8 \left[\mu t \alpha^{3/2} \left(\frac{U}{\Delta P_{exp}} \right) \right]^{1/2} \tag{10}$$

where ΔP_{exp} is the experimentally measured filter pressure drop.

Filter media M2U was made of two meltblown layers. These layers, as explained in the introduction section, were electrostatically charged. The corona charge of media was removed to evaluate the pure mechanical performance of the samples and to compare with theoretical calculated results. Then these samples free of electrostatic charge were tested and the data were compared with theoretical calculations. Samples of M2U media were dipped in isopropanol for 10 minutes to remove the charge. Hereafter, these samples are referred to as M2U-2. After drying for 24 hours, M2U-2 samples were examined under the same experimental conditions as charged media M2U. This method was used to simulate the case where the charge decay occurs and the filter performance would be the same as the one of the media M2U-2.

Quality factor is defined as a relation between filter particle collection efficiency and the pressure drop [8,] as described in the equation below:

$$QF = \frac{-\ln(1-E)}{\Delta P_{exp}} \tag{11}$$

where E is the particle collection efficiency and is calculated using the Eq. (1). ΔP_{exp} represents the measured pressure drop value. Usually, the quality factor is taken as a measure of how good a filter media is compared to other products. Good quality factor means the media will exhibit high collection efficiency and low pressure drop.

3. Test Material

Three filter layers, meltblown layer with an mean fiber diameter of 2 μm (MB-2), meltblown layer with an mean fiber diameter of 5 μm (MB-5), and thermalbond layer with mean fiber size of 35 μm (TB) were used for design of composite filter media M1U and M2U. Due to its mechanical strength, TB can be considered only as a substrate. Commercial filter media RefM was used for comparison of filtration performance. Scanning electron microscope (SEM) images of M1U and M2U are displayed in the Fig. 2, showing the layer arrangement and their fibrous structure.

KCl particles were generated using the atomizer, TSI model 9302. A 1%wt KCl solution was used to generate particles with a

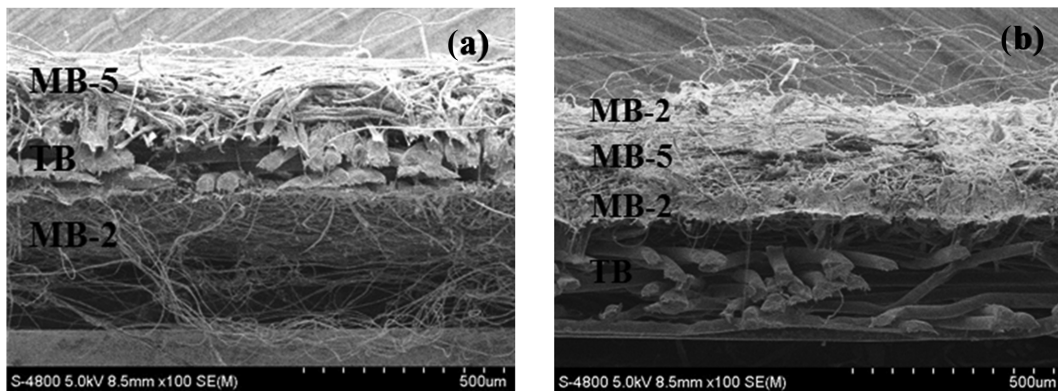

Fig. 2. Cross section SEM image (x100) of filter media (a) M1U and (b) M2U.

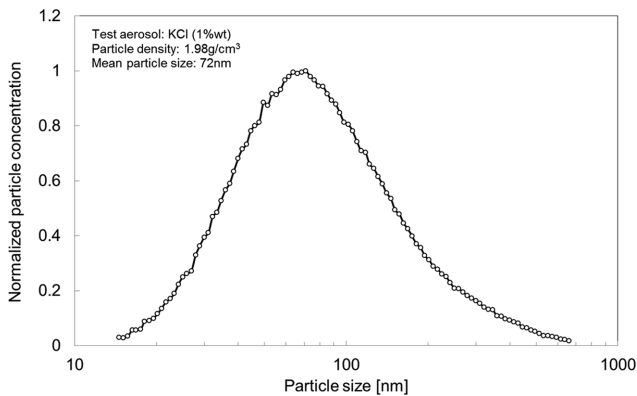

Fig. 3. KCl particle size distribution (normalized).

mean particle size of 72 nm. Size distribution is displayed in the Fig. 3. Particles were passed through diffusion dryer and neutralizer to remove the particle charge and water content.

RESULTS AND DISCUSSION

1. Pressure Drop Characteristics of Clean Filter Media

Pressure drop characteristics of media vary according to the filter media structure and the arrangement of the layers. Media M1U consists of the upstream fine fiber meltblown layer MB-5 supported by thermalbond layer and MB-2 layer as the final layer (Fig. 2(a)). Fine meltblown fibers have a dense packing structure, which is considered as a major contributor to pressure drop. Thermalbond layer is made of large diameter fibers bonded to each other thermally, which suits well as a good substrate. Thermally bonded fibers make a fixed web with certain stiffness. Media M2U (Fig. 2(b)) is composed of three meltblown layers, MB-5 in the middle and MB-2 up- and downstream. Thermal-bond layer is placed as substrate layer. From Table 1 we can read the air permeability which is directly related to pressure drop of the media. It is generally known that the layer with high air permeability will exhibit low pressure drop. Based on the air permeability of the layer TB, it is expected that this layer will have a less significant contribution to

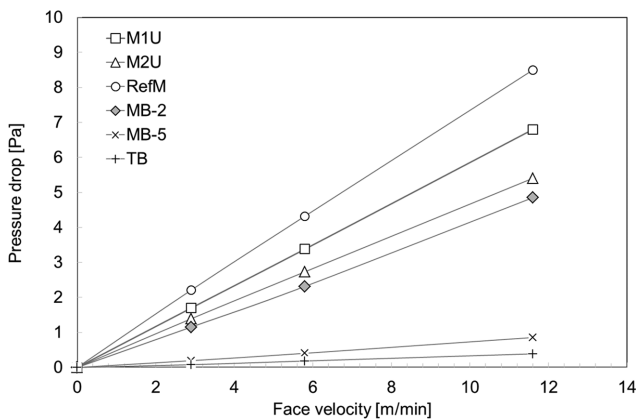

Fig. 4. Pressure drop characteristics of clean filter media M1U and M2U.

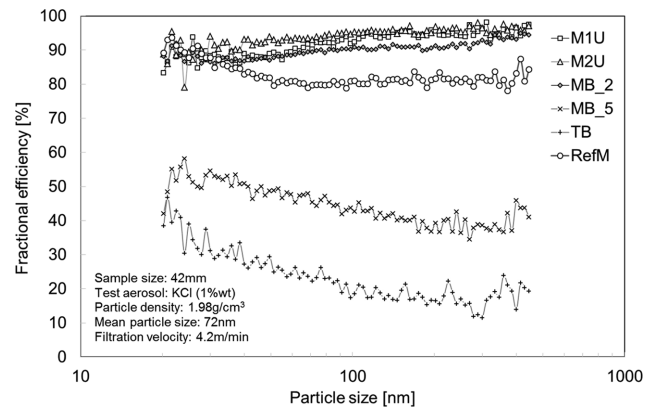

Fig. 5. Fractional collection efficiency vs. particle size for media and layers.

particle retention. The layer MB-5 exhibits also a low pressure drop due to thin layer of fiber packing.

2. Particle Collection Characteristics

Both filter media, M1U and M2U, exhibit higher collection efficiency compared to the reference media even though the media RefM exhibits higher pressure drop than the other two filter media. One reason for this phenomenon is that RefM is three times thicker than media M1U and M2U. As expected, the layers MB-5 and TB exhibit low collection efficiency. The layer MB-2 is the main contributor to the high particle collection efficiency of the new composite media M1U and M2U. Adding the layers MB-5 and TB does not contribute significantly to increase in particle collection efficiency, as shown in Fig. 5.

3. Filtration Performance According to Particle Loading

The change in layer arrangement shows the effect on the pressure drop. When a high efficiency layer is placed upstream, most of the particles are collected on its surface. This leads to fast increase of the pressure drop starting from a point known as the clogging point. It describes the stage when the void space between fibers is filled with particles and the further collection of particles occurs predominately on its surface. That is why the pressure drop of media M2U increases faster than that of other two test media (Fig. 6).

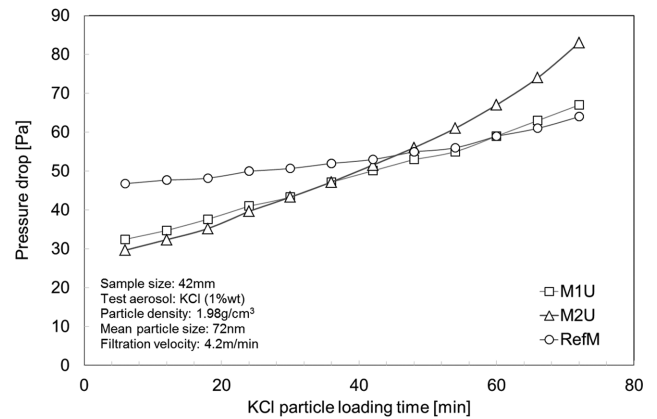

Fig. 6. Pressure drop characteristics of filter media M1U, M2U and RefM as function of loading time.

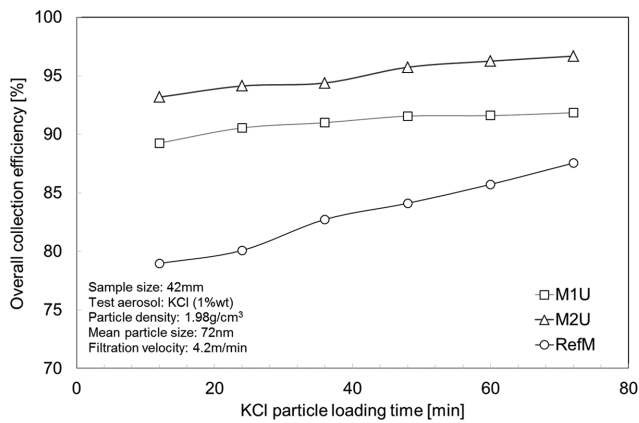

Fig. 7. Overall collection efficiency of filter media M1U, M2U and RefM as function of loading time.

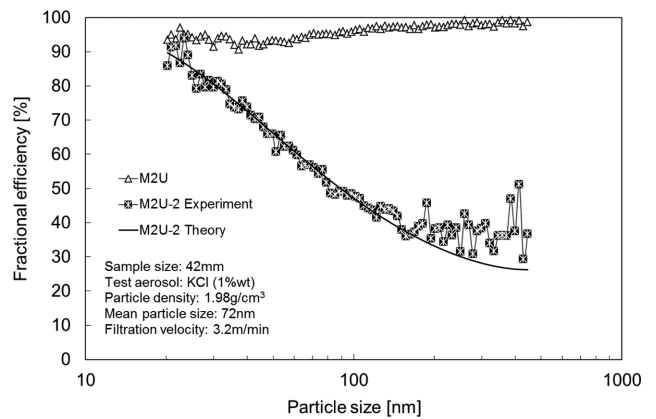

Fig. 9. Theory calculation and experimental results for media M2U and M2U-2.

Generally, the filter media of moderate efficiency exhibit gradual increase of efficiency with continuous particle loading, as can be seen in case of the reference media RefM in the Fig. 7. For media M1U and M2U, the particle collection efficiency increases slowly with loading of particles. As can be seen from SEM images, taken after the loading test (Fig. 8), the dendrite structure advances to the stage where they collide and block the inter-fiber space inside the layer. As the dust cake is formed on the surface of the media, collection of particles is regarded as particle cake filtration. This is the reason why the pressure drop increase has a sharper slope from the point where depth filtration turns to surface filtration mechanism.

4. Comparison of Experimental Data with Filtration Theory Calculations

Single fiber collection efficiency calculations have been largely used for prediction of the filter media. Theory calculations were done using the equations described for single fiber efficiency due to Brownian diffusion [11] and due to interception [12]. These two mechanisms are the most influential for the particle range observed in this study. Effective fiber diameter [13] was calculated for given experimental pressure drop value ΔP_{exp} and the filter media properties such as thickness, specific weight and fiber density. In this study, for effective fiber diameter D_{fd} of 10 μm , theory calculations of single fiber collection efficiency due to Brownian diffusion and interception agree well with the experimental results and deviate slightly for the particles larger than 0.2 μm (Fig. 9). The dif-

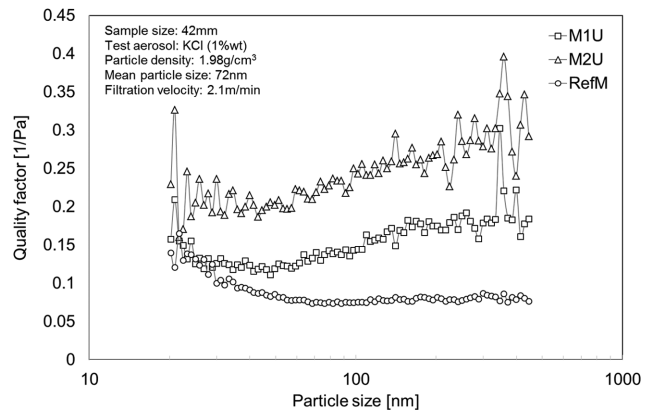

Fig. 10. Quality factor vs. particle size at face velocity 2.1 m/min.

ference in particle collection efficiency is due to the electrostatic charge. Especially for the particle size of round 0.3 μm , known as most penetrating particle size (MPPS), the difference is significant.

5. Quality Factor

Quality factor is often introduced for comparison of the various media with other reference samples. It also brings the two most important filtration parameters into one expression. By designing the composite filter media, the aim is to reduce the pressure drop and increase the efficiency, which would lead to higher quality fac-

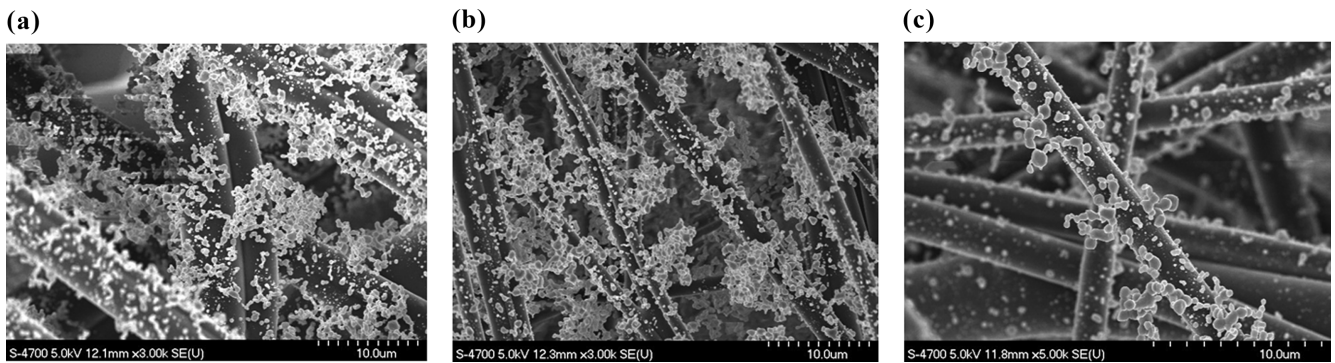

Fig. 8. Particle collection on the fibers of the upstream layer of (a) media M1U, (b) media M2U and (c) RefM.

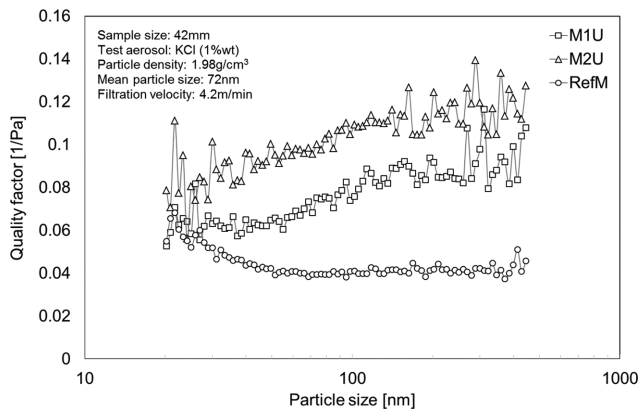

Fig. 11. Quality factor vs. particle size at face velocity 4.2 m/min.

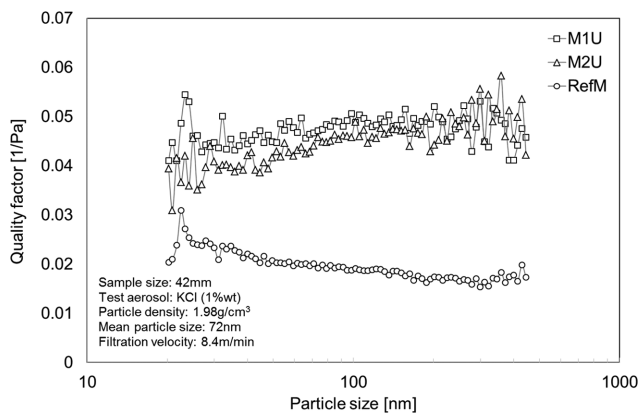

Fig. 12. Quality factor vs. particle size at face velocity 8.4 m/min.

tor values.

As the face velocity is increased, the quality factor of media M1U almost equals the media M2U. Reference media shows an almost steady quality factor for the measured range of particles and even started decreasing at the face velocity of 8.4 m/min (Fig. 10-12). The gap between the new composite media, M1U and M2U, and the reference media increased as the filtration velocity increased due to the pressure drop characteristics displayed in the Fig. 4.

CONCLUSIONS

Two new composite filter media were designed for application in an HVAC system aiming at the efficient collection of nanoparticles. These media were made of meltblown and thermalbond layers. These tests show how significant the layer composition and the placement of the fine fiber layer inside the media can be for the media filtration performance.

Media M1U and M2U exhibited lower pressure drop than the media RefM and higher particle collection efficiency. This would not be possible without the electrostatic charge applied to MB layers. The single layers were treated by a corona charging of 40 kV high voltage. The charge causes the particles to form dendrite structures along the surface of the fibers and prevents the particles from directly blocking the inter-fiber void space. But the charge effect

decreases the further the particles are from the fiber.

Dust loading tests reveal two significant phenomena: first, at the initial stage the high efficiency filter media M2U performs better than the other two media. With further loading of particles, the dust cake is formed, and the pressure drop curve indicates the clogging of the media M2U expressed in a sharp rise of pressure drop. This would be a problem for high particle concentration environment. Due to thickness of the media, RefM pressure drop increased slowly. This is related to less effective particle collection as well as high particle holding capacity.

Tests with media M2U and M2U-2 demonstrated how poor would be the collection efficiency without electrostatic charge. We can conclude that the theory calculations agree well with the media without charge but underestimate the efficiency of the charged media, as these calculations do not consider the electrostatic effect. Even without the charge, the media exhibit high particle collection efficiency. This would be advantageous compared to the existing HVAC filter media. High efficiency grade media generally are composed of electrospinning nanofibers characterized by high collection efficiency and high pressure drop. A solution then would be media like M2U, composed of meltblown fibers. These fibers are larger than those made by the electrospinning method and compensate the efficiency through the electrostatic charge.

We plan to apply these media for collection of nanoparticles in an HVAC system by combining the fine fiber filtration unit with ionization unit placed upstream of the filter. As future work we plan to challenge these composite media with unipolar and bipolar charged particles and observe their filtration performance.

ACKNOWLEDGEMENTS

This work was supported by the Korea Institute of Energy Technology Evaluation and Planning (KETEP) and the Ministry of Trade, Industry & Energy (MOTIE) of the Republic of Korea (No. 20171120100560).

NOMENCLATURE

| | |
|------------------|--|
| C_u | : upstream particle concentration [mg/m ³] |
| C_d | : downstream particle concentration [mg/m ³] |
| C_C | : cunningham slip correction factor |
| D | : diffusion coefficient |
| D_{fd} | : effective fiber diameter [m] |
| ΔP_{th} | : theoretical pressure drop [Pa] |
| ΔP_{exp} | : measured pressure drop [Pa] |
| d_f | : fiber diameter [m] |
| d_p | : particle diameter |
| E | : particle collection efficiency [%] |
| E_D | : efficiency due to Brownian diffusion |
| E_R | : efficiency due to interception |
| E_I | : efficiency due to impaction |
| E_G | : efficiency due to gravity |
| g | : gravity acceleration [m/s ²] |
| K_b | : boltzmann constant [J/K] |
| Ku | : Kuwabara hydrodynamic factor |
| Pe | : Peclet number |

| | |
|----------|------------------------------|
| QF | : filter quality factor |
| R | : interception parameter |
| t | : filter media thickness [m] |
| T | : temperature [K] |
| U | : approaching velocity [m/s] |
| α | : solidity factor |
| η | : filtration efficiency [%] |
| μ | air viscosity [Pa s] |
| π | : pi number |

REFERENCES

1. P. Biswas and Ch.-Y. Wu, *J. Air Waste Manage. Assoc.*, **55**, 708 (2005).
2. P. Schulte, C. Geraci, R. Zumwalde and M. Hoover, *J. Occup. Environ. Hyg.*, **5**, 239 (2008).
3. J. Marra, M. Voetz and H.-J. Kiesling, *J. Nanopart. Res.*, **12**(1), 21 (2010).
4. D. Dan and B. Pourdeyhimi, *Composite nonwoven materials: Structure, properties and applications*, Woodhead Publishing, Cambridge (2014).
5. E. R. Frederick, *J. Air Pollut. Control Assoc.*, **30**(4), 426 (1980).
6. I. M. Hutten, *Handbook of nonwoven filter media*, Elsevier, Oxford (2007).
7. C. W. Nam, S. K. Lee, M. Ryu, J. W. Lee and H. M. Lee, *Korean J. Chem. Eng.*, **36**(10), 1565 (2019).
8. W. C. Hinds, *Aerosol technology, properties, behaviour and measurement of airborne particles*, Wiley, New York (1982).
9. J. Wang, S. C. Kim and D. Y. H. Pui, *J. Aerosol Sci.*, **39**, 323 (2008).
10. R. C. Brown, *Air filtration, an integrated approach to the theory and applications of the fibrous filters*, Pergamon Press, Oxford (1993).
11. J. Wang, D. R. Chen and D. Y. H. Pui, *J. Nanopart. Res.*, **9**, 109 (2007).
12. K. W. Lee and B. Y. H. Liu, *Aerosol Sci. Technol.*, **1**, 147 (1982).
13. K. W. Lee and R. Mukund, in *Aerosol measurement-principles, techniques, and application*, P. A. Baron and K. Willeke Eds., Wiley, New York (2001).