

## Carbon capture from stationary power generation sources: A review of the current status of the technologies

Muhammad Zaman and Jay Hyung Lee<sup>†</sup>

Department of Chemical and Biomolecular Engineering,  
Korea Advanced Institute of Science and Technology, Daejeon 305-701, Korea  
(Received 26 April 2013 • accepted 15 July 2013)

**Abstract**—The world will need greatly increased energy supply in the future for sustained economic growth, but the related CO<sub>2</sub> emissions and the resulting climate changes are becoming major concerns. CO<sub>2</sub> is one of the most important greenhouse gases that is said to be responsible for approximately 60% of the global warming. Along with improvement of energy efficiency and increased use of renewable energy sources, carbon capture and sequestration (CCS) is expected to play a major role in curbing the greenhouse gas emissions on a global scale. This article reviews the various options and technologies for CO<sub>2</sub> capture, specifically for stationary power generation sources. Many options exist for carbon dioxide capture from such sources, which vary with power plant types, and include post-combustion capture, pre-combustion capture, oxy fuel combustion capture, and chemical looping combustion capture. Various carbon dioxide separation technologies can be utilized with these options, such as chemical absorption, physical absorption, adsorption, and membrane separation. Most of these capture technologies are still at early stages of development. Recent progress and remaining challenges for the various CO<sub>2</sub> capture options and technologies are reviewed in terms of capacity, selectivity, stability, energy requirements, etc. Hybrid and modified systems hold huge future potentials, but significant progress is required in materials synthesis and stability, and implementations of these systems on demonstration plants are needed. Improvements and progress made through applications of process systems engineering concepts and tools are highlighted and current gaps in the knowledge are also mentioned. Finally, some recommendations are made for future research directions.

Key words: Carbon Capture Technologies, Absorption, Adsorption, Membranes, Process Systems Engineering

### INTRODUCTION

Carbon dioxide is claimed to be responsible for 60 percent of the global warming caused by greenhouse gases (GHGs) [3]. There are three ways to reduce CO<sub>2</sub> in the atmosphere: 1) More efficient use of energy, 2) Use of alternative fuels and energy sources, and 3) CO<sub>2</sub> capture and sequestration (CCS). The CCS process involves CO<sub>2</sub> separation (from either stack gas or other intermediate gas streams) followed by pressurization, transportation, and sequestration. According to the International Energy Agency's roadmap, 20 percent of the total CO<sub>2</sub> emissions should be removed by CCS by year 2050 [4]. A majority of current research efforts are devoted to the carbon dioxide removal from stationary power production sources, and understandably so. First, these sources are by far the most dominant contributors of the CO<sub>2</sub> emission, accounting for roughly 47 percent [5] of the total anthropogenic CO<sub>2</sub> emissions. In addition, they share many similarities with the existing processes, where carbon dioxide capture has been used for many decades, and hence technologies for capturing CO<sub>2</sub> from stationary sources are more mature than those for capture from mobile sources like transportation devices. Finally, due to the economies of scale, it is economically more attractive to implement CCS technologies on large-scale power plants, at least within some foreseeable future.

CO<sub>2</sub> capture is the most expensive part of CCS, accounting for

more than 75% of the estimated overall CCS cost [6]. There are several commercial technologies available for CO<sub>2</sub> separation. These were developed mainly for the production of pure CO<sub>2</sub> (for use in food processing and chemical manufacturing), the removal of CO<sub>2</sub> from natural gas, and hydrogen purification. In these cases, CO<sub>2</sub> was obtained as a valuable product and the capture process was relatively of small scale as compared to those needed for power plants. Therefore, when the existing separation technologies are implemented on large scale power plants, they are not cost effective [7], due to a much higher volumetric rate of low-pressure flue gases that need to be treated and the presence of impurities such as sulfur dioxide. Demonstration plants for most of the capture technologies are absent, and at present none of the technologies have been commercialized on such a large scale. When CCS is implemented in a typical pulverized coal power plant, the cost of electricity is estimated to increase by about 80% and the generating capacity decrease by 30%. The goal is to reduce this electricity cost increase to less than 35% for pulverized coal power plants, according to the US Department of Energy (DOE) [7].

This paper is intended to provide a review of the current status of technologies for carbon capture, both the traditional and the emerging. For the reasons stated above, we choose to focus on carbon dioxide capture from power production sources, including both coal and natural gas fired power plants. Our goal is to provide a glimpse into the current technology portfolio, compare the relative merits and demerits of the various options, highlight some promising directions, and identify shortcomings and challenges, especially those

<sup>†</sup>To whom correspondence should be addressed.  
E-mail: jayhlee@kaist.ac.kr

that can be overcome by further research and development efforts. By doing so, it is hoped that interests and understandings of the field among the chemical engineers will increase, and more researchers will become engaged in this important topic. Recently, several reviews on carbon dioxide capture have been published [8-14]. This review paper is intended to complement them by filling in some of the gaps left by the previous review papers. These include details of physical solvent processes and lithium based compounds, as well as applications of process systems engineering concepts and tools that can help speed up the progress by identifying the key parameters of CO<sub>2</sub> capture processes from the overall economics and operational feasibility.

Different options exist for carbon capture, and their viability and appropriate choice depend on the type of power plant. Main configurations being considered include: (1) post-combustion capture, (2) pre-combustion capture, (3) oxy fuel combustion capture, and (4) chemical looping combustion (CLC) capture. For a given configuration, a specific separation technology can be adopted for separating CO<sub>2</sub> from a targeted gas mixture stream (flue gas or fuel gas). Here again, a number of choices are available, some of which are being widely used these days, mainly in various industrial purifications, e.g., natural gas treatment, and production of hydrogen, ammonia, and other industrial chemicals [14]. Fig. 1 lists the various technical options for separation of CO<sub>2</sub> from a gas mixture stream, and they include chemical absorption, physical absorption, adsorption, cryogenics, and membranes.

Many of the CO<sub>2</sub> separation technologies are discussed extensively in the literature, including chemical absorption [15-21], physical absorption [22-24], adsorption [25-39], membrane separations [40-49] and some of the novel separation techniques [50-53]. The right choice of technology depends on the type of power plant (and thus the conditions of the gas stream to be treated, e.g., temperature, pressure and concentration of the CO<sub>2</sub>), targeted purity level, economics, reliability, etc.

One finds a broad range of maturity levels for the carbon dioxide capture technologies listed in Fig. 1. At the one end of the spectrum, mature commercialized technologies such as amine-based absorption can be found; present at the other end are newer concepts like modified membranes and adsorption, which hold high promise and have significant room for improvement but are yet to be tested beyond the setting of a research laboratory. Excellent performance and significant cost savings have been claimed for a number of advanced lab scale technologies, and hence these technologies are expected to be fully tested in near future. Many of the performance claims should be taken with caution as they often carry significant uncertainty at such an early stage of development. This should change as the new technologies advance towards maturity and commercialization.

In the remainder of the paper, relative advantages and disadvantages, important parameters, and key uncertainties are presented in depth for the above-mentioned current and promising technologies one by one. In addition, progress and improvement made through the application of process systems engineering concepts and tools, e.g., modeling/simulations, process optimization/integration, control/operation, and molecular simulations, are highlighted. Remaining issues and hurdles for these technologies to be used for CO<sub>2</sub> capture at commercial scales are also mentioned. At the end, some recommendations are also given.

Relative levels of progress and maturity vary greatly for the discussed technologies. For example, significantly more results for chemical absorption can be found in the literature because it is by far the most matured among them. Because of this, depth and quality of the review may seem somewhat unbalanced among the different technologies. In addition, most discussions given are of qualitative nature, though we try to provide quantitative data where possible. Finally, though we made our best attempt to provide a thorough review of the literature on the carbon capture technologies for point stationary sources, we inevitably may have overlooked some impor-

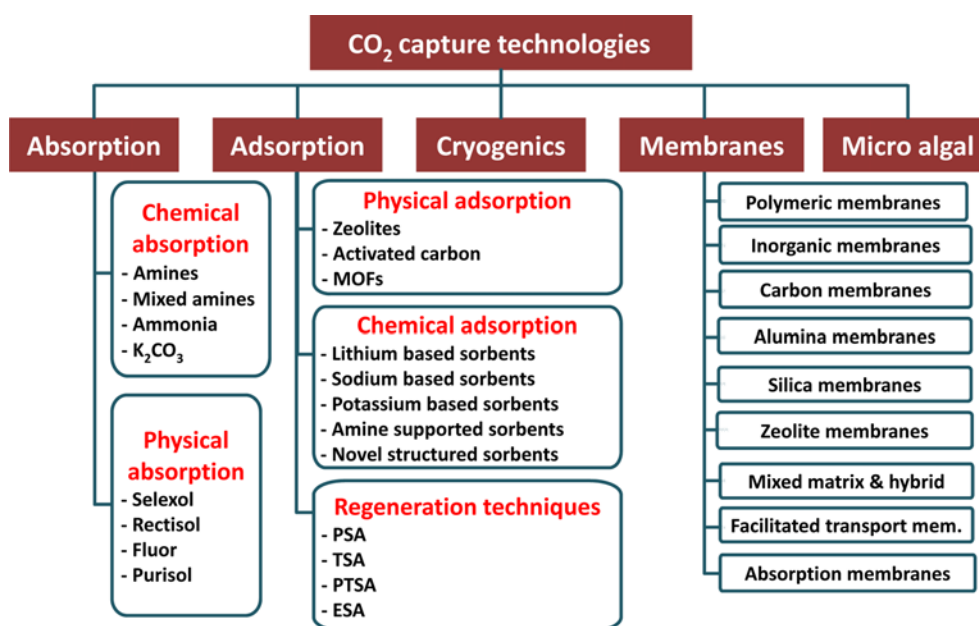

Fig. 1. Overview of carbon dioxide capture technologies (modified from A. B. Rao and S. Rubin, 2002 [2]).

tant works and we apologize for such omissions.

## CONTEXTS FOR CO<sub>2</sub> CAPTURE BASED ON TYPE OF POWER PLANTS

Several options exist for implementing carbon dioxide capture and they vary according to the type of power plant (type of fuel used, combined production of hydrogen, combustion type etc.). Carbon capture can broadly be classified into four major types: post-combustion capture, pre-combustion capture, oxy-combustion capture, and chemical looping combustion capture. Current status of these options can be found in the literature [1,14].

### 1. Post-combustion Capture

Post-combustion capture, shown in Fig. 2, involves capture of CO<sub>2</sub> from flue gas after the power generation step, and the separation of CO<sub>2</sub> is mainly from nitrogen and relatively little amounts of oxygen and water. Post-combustion CO<sub>2</sub> capture is mainly for pulverized coal (PC), oil-fired or gas-fired power plants, but it can also be applied to cases of IGCC and natural gas combined cycle (NGCC) flue gas capture. The advantages of post-combustion capture include: 1) all the existing power plants can be retrofitted without any or with only minor modifications, 2) energy demand of the power plant can be controlled by adjusting the CO<sub>2</sub> capture level, or by bypass-

ing the CO<sub>2</sub> capture step at the times of peak loads; and 3) it can be applied to capture CO<sub>2</sub> from industrial manufacturing, e.g., cement industry, steel industry [5].

Due to low concentrations (4-15% by volume) of carbon dioxide and low overall stream pressure in comparison to traditional sources of CO<sub>2</sub> where the feed gas is at high pressure, the partial pressure of CO<sub>2</sub> in flue gas is much lower. Since CO<sub>2</sub> at such a low concentration level cannot be captured effectively by physical absorption, chemical absorption is likely to be needed. This is because physical absorption depends on the partial pressure for absorption, whereas chemical absorption is less dependent on it. A large volume of low pressure steam is required for the regeneration of the chemical solvent, decreasing the generation capacity of the power plant. Reasons for all the inefficiencies of post-combustion capture include the low concentrations of CO<sub>2</sub> in flue gas, large volumes of flue gas to be treated, the requirement of compressing CO<sub>2</sub> from the atmospheric pressure to the storage pressure, and the relatively high temperature of flue gas, which needs to be cooled before the CO<sub>2</sub> capture. Temperature and pressure swing adsorption and membranes can also be used for separating CO<sub>2</sub> from nitrogen in post-combustion capture. However, flue gas contains contaminants such as sulfur dioxide that are problematic to remove (for the same reason as in CO<sub>2</sub> removal) and negatively impact the performance of many tech-

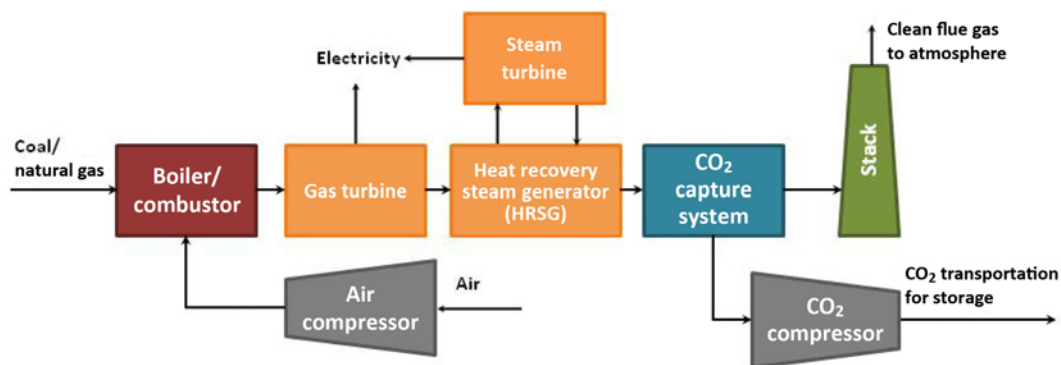

Fig. 2. Schematic of an amine-based post-combustion CO<sub>2</sub> capture system applied to a NGCC power plant (modified from peter folger, 2010 [1]).

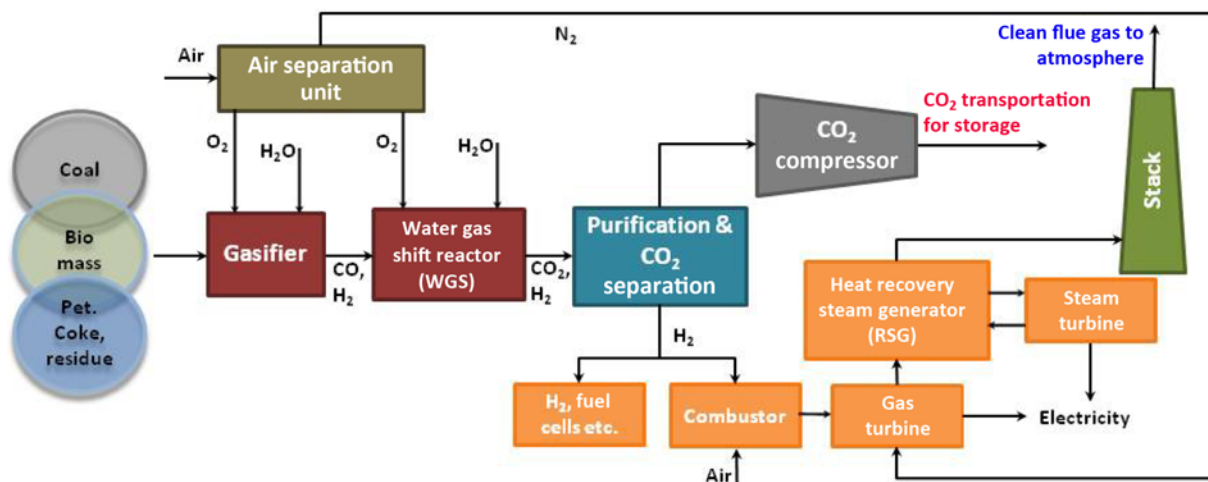

Fig. 3. Schematic of IGCC power plant with pre-combustion capture (modified from E. S. Rubin, 2008 [277]).

nologies (such as adsorption). In addition, the gas is almost saturated with water, which makes selective absorption or adsorption of  $\text{CO}_2$  relative to water critical.

## 2. Pre-combustion Capture

In coal-fired power plants, when coal reacts with oxygen and steam at high temperatures and pressures, it produces syngas (mixture of carbon monoxide and hydrogen) in a process called gasification. After the gasification step, syngas reacts with steam in the so-called water gas shift reactor, which converts the carbon monoxide to  $\text{CO}_2$ , producing a mixture of mainly  $\text{CO}_2$  and  $\text{H}_2$ . Pre-combustion capture involves the capture of  $\text{CO}_2$  from this fuel gas (mixture of  $\text{CO}_2$  and  $\text{H}_2$ ), leaving just hydrogen for the power generation. It therefore involves separation of hydrogen from  $\text{CO}_2$  along with minor amounts of water, carbon monoxide, and oxygen. This type of power plant shown in Fig. 3 is called an integrated gasification combined cycle (IGCC) power plant using coal, biomass, or their mixture. The sulfur compounds are removed from fuel gas prior to the  $\text{CO}_2$  capture. DOE's Fuel Cell Program includes an application to utilize hydrogen for solid oxide fuel cells (SOFC) that can further increase the overall efficiency of the plant [7]. When pre-combustion capture is applied to natural gas power plants, natural gas is first converted to syngas in the presence of oxygen and steam through a process called reforming.

As compared to the post-combustion capture, pre-combustion capture is much easier and cheaper, but fuel conversion steps are costly [1]. Physical absorption can be effective since the  $\text{CO}_2$  concentration and pressure are higher. However, the gas stream needs to be cooled before physical absorption can be performed. Fuel gas after the capture needs to be heated back up before being sent to the combustion chamber. Temperature and pressure swing adsorption and membranes can also be employed for the  $\text{CO}_2$  separation from hydrogen in pre-combustion capture.

## 3. Oxy-combustion Capture

Oxy fuel combustion capture, as shown in Fig. 4, is a kind of post-combustion capture, but the fuel is burnt with pure oxygen instead of air, so that the exhaust gases contain only  $\text{CO}_2$  and water. Therefore, the  $\text{CO}_2$  separation can be done by condensation of the water. A major advantage of oxy fuel combustion is that the cost of post-combustion capture is much lower. However, the air separation to generate pure oxygen required for combustion can be costly for a large scale power plant. Almost three times more oxygen is required

for an oxy-combustion power plant as compared to an IGCC power plant of equal size [1]. Another challenge is that temperatures for oxy fuel combustion are much higher than those for air-combustion; therefore, a large amount of inert flue gas must be recycled to the boiler to maintain operating temperatures at levels similar to in air-combustion [1]. Also, there is limited experience for this technology, since there is a lack of full scale demonstration power plants.

Flue gas of high  $\text{CO}_2$  concentration is produced in an oxy-combustion power plant and it is balanced with water, which is separated by condensing. Improvements are needed in the air separation by use of cryogenics and the development of alternative cost-effective oxygen production technologies. This technology can be applied to both new and existing plants. Oxy-combustion technology is still at an early stage of development, but some pilot plants are being built and there are advanced-stage plans for building commercial scale power plants [54].

## 4. Chemical Looping Combustion

A new sorbent-based oxygen production technology, called chemical looping combustion (CLC), has been developed and received much attention lately [55-58]. This technology can be viewed as a variation of oxy-fuel combustion with the promise of much lowered costs. It was originally proposed by Richter and Knoche (1983)[59] and then further developed by Ishida and Jin (1994) [60]. Chemical looping combustion is carried out in two fluidized beds: the 'air reactor' performing the oxidation reaction and the 'fuel reactor' performing the reduction reaction. The metal oxide releases  $\text{O}_2$  in the latter and the released  $\text{O}_2$  reacts with fuel. The reduced metal from the fuel reactor is recycled back to the air reactor where it forms metal oxide upon contact with air, as shown in Fig. 5. The terminologies of oxidation and reduction are with respect to metal and metal oxide. Hence, combustion products are  $\text{CO}_2$  and  $\text{H}_2\text{O}$ , and this simplifies the  $\text{CO}_2$  capture task as it is much easier to separate  $\text{CO}_2$  from  $\text{H}_2\text{O}$  or  $\text{H}_2$  than from  $\text{N}_2$  with current technologies [61]. An almost 100% pure stream of  $\text{O}_2$  can be produced for the combustion of fuel [62]. A number of  $\text{O}_2$  carrier materials are under consideration that include copper [63,64], iron [65,66], manganese [67], nickel [68,69], calcium [70], and various minerals [52,71].

A 120-kilowatt unit is being tested in Austria [51], and two chemical looping test facilities are currently funded by the US DOE, one by Alstom [72] based on calcium compounds as an  $\text{O}_2$  carrier, and second at the Ohio State University [55] based on an iron oxide  $\text{O}_2$

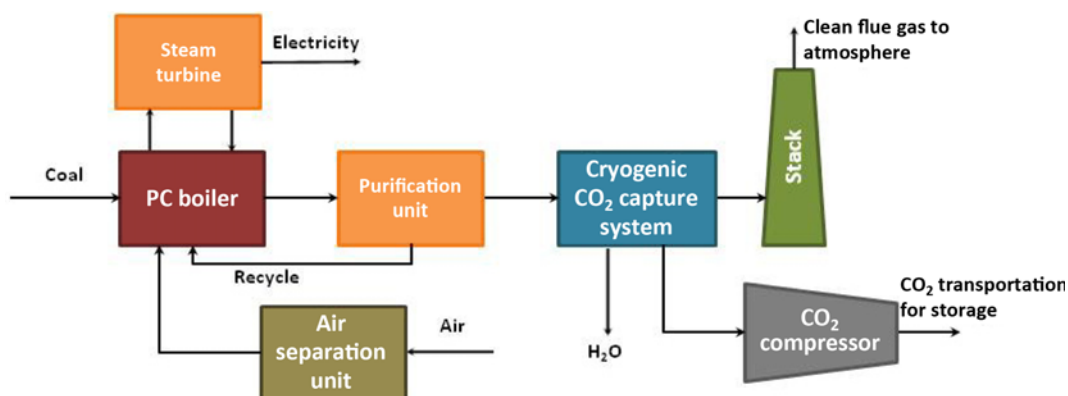

Fig. 4. Schematic of an oxy-combustion coal-fired power plant (modified from E. S. Rubin, 2008 [277]).

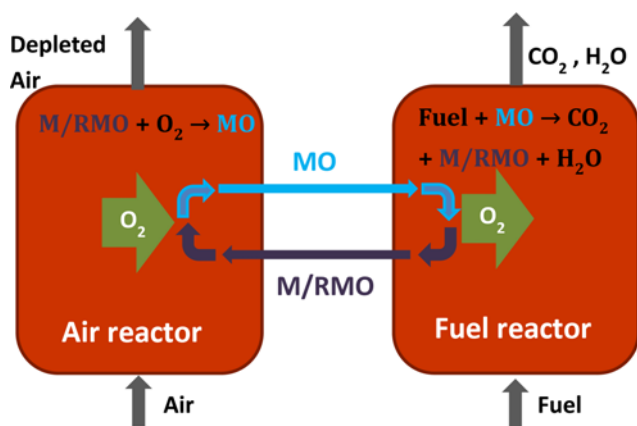

Fig. 5. Schematic of a chemical looping combustion (CLC) system.

carrier [14]. In chemical looping gasification (CLG), one loop is used to gasify the coal and produce syngas and the second loop performs the water gas shift reaction to convert CO into H<sub>2</sub> and CO<sub>2</sub>. CO<sub>2</sub> can then be released in the calcination step [5]. An initial cost analysis of CLC for carbon capture has shown that it could be very cost-effective [73]. Superior performance of CLC against IGCC with pre-combustion capture using physical absorption has been shown, such as 100% CO<sub>2</sub> removal compared to 86% for physical absorption in IGCC and specific CO<sub>2</sub> emissions of 7 kg/MWhe compared to 125 kg/MWhe [74]. Since metal particles experience repeated cycles of oxidation and reduction at high temperatures, mechanical and chemical stability are the main issues to be solved in order to minimize operational problems and the amount of makeups needed and to obtain a desired quantity and purity of pure O<sub>2</sub>. The operating temperature ranges from 800 °C to 1,200 °C [5]. Some amount of steam is required to be used along with the fuel so as to avoid deposit of carbon in the reduction reactor [5].

## CHEMICAL ABSORPTION

In chemical absorption, CO<sub>2</sub> present in the gas stream reacts with a chemical solvent to form some intermediate compound(s). As a result, CO<sub>2</sub> is removed from the exhaust flue gas. The solvent solution, which contains the intermediate compounds, is heated with low pressure steam for recovery and the released CO<sub>2</sub> is captured, pressurized, transported, and then stored. The recovered solvent, which contains just small amounts of dissolved CO<sub>2</sub> and its intermediate compounds, is then recycled back to the absorption process. When chemical solvents are used for a high gas stream flow with a relatively low partial pressure of CO<sub>2</sub>, challenges are of scale, efficiency, stability, and corrosion. A large amount of solvent is required that undergoes significant changes in its condition, and this leads to high capital investments and energy costs [75].

Chemical absorption by monoethanolamine (MEA) is by far the most mature technology for post-combustion capture. In spite of all the disadvantages, chemical absorption (MEA) is the only commercialized mature technology for post-combustion capture. Only minor improvements may be possible for the MEA process because much research has already been conducted during the past 60 years or so. On the other hand, the stability of the amines and energy consumption of the stripping process have large room for improvement.

Use of mixed amines (primary, secondary, and tertiary) has been reported to give improvements over individual amines, i.e., larger reactivity and stability, reduced circulation rates, and low regeneration costs.

### 1. Chemical Solvents

A number of chemical solvents can be used for CO<sub>2</sub> capture through chemical absorption, such as amines, ammonia, and potassium carbonate. Favorable properties of commercial absorbent for carbon dioxide separation from a gas stream include high absorption capacity, high absorption rates for CO<sub>2</sub>, high thermal and chemical stability, low regeneration energy requirements, low vapor pressure, low molecular weight, low viscosity and low corrosion rates.

#### 1-1. Amines

Monoethanolamine (MEA) is by far the most popular solvent for chemical absorption based CO<sub>2</sub> separation. CO<sub>2</sub> from the gas stream is absorbed into the solution of MEA and water. MEA reacts with CO<sub>2</sub> and forms amine protonate, bicarbonate, and carbamate. When enough CO<sub>2</sub> is loaded into this solution, the solution is heated with steam to a higher temperature, which releases CO<sub>2</sub> in relatively pure form for capture, compression, and storage. The liquid solution, which contains small remaining amounts of CO<sub>2</sub>, is then recycled back for further use in the CO<sub>2</sub> separation. Other impurities, such as sulfur, nitrogen oxides, and particulate matter, are removed prior to the separation of CO<sub>2</sub>, in order to avoid irreversible poisoning of the solvent and to increase the capacity of CO<sub>2</sub> for absorption. Due to the high enthalpy of reaction, MEA absorbs CO<sub>2</sub> at fast rates. On the other hand, a large amount of energy is required to remove the dissolved CO<sub>2</sub> and recover the solvent. In addition, oxygen present in the gas stream causes degradation of the solvent and produces corrosive products [76-79].

Amines can be classified as primary amines (monoethanolamine (MEA), diglycolamine (DGA)), secondary amines (diethanol amine (DEA), diisopropyl amine (DIPA)) and tertiary amines (triethanol amine (TEA), methyldiethanol amine (MDEA)). They have different reaction rates, absorption capacity, reaction enthalpy, stability and corrosion.

Some hindered amines as well as secondary and tertiary amines can be used for CO<sub>2</sub> capture, and these solvents possess good properties such as larger capacity of CO<sub>2</sub>, less corrosion, degradation resistance, and lower energy penalty for regeneration as compared to MEA [80]. Primary amines upon reacting with CO<sub>2</sub> form a carbamate amine and a protonated amine; theoretical capacity is limited to 0.5 moles of CO<sub>2</sub> per mole of amine. However, a different formulation (i.e., reaction products) in secondary and tertiary amines increases the theoretical capacity of CO<sub>2</sub>. Hence these advanced formulations and improved process designs have reduced the energy penalty to 2.9-3.2 MJ/kg of CO<sub>2</sub> capture as compared to 3.9-4.2 for MEA [19]. DEA has been found to possess good properties such as higher capacity for CO<sub>2</sub>, lower dependence on CO<sub>2</sub> partial pressure and energy savings since the stripper can be operated at a lower temperature level. This is because of the chemical structure and reactions of DEA [19]. Sterically hindered amines, e.g., 2-amino-2-hydroxymethyl-1,3-propanediol (AHPD), have shown similar capacity and less regeneration energy penalty than MEA. Solubilities of carbon dioxide in 10 mass% aqueous AHPD solution have been found to be higher when compared to those in 10 mass% aqueous MEA solutions above the partial pressure of 4 kPa at 298.15 K, but

the solubility behavior reversed below partial pressure of 4 kPa [81].

#### 1-2. Mixed Amines

When two or more amines are mixed, the performance of the blended amines is shown to combine the favorable properties of the individual amines as well as to overcome some of the unfavorable ones. An important factor here is the extra design degree of freedom afforded by mixing the amines in varying concentrations. Dramatic improvements have been reported in terms of reduced capital and operating costs and increased the flexibility for achieving desired separation for a specified gas stream [82]. Advantages of mixed amines are higher rates of reaction of the primary/secondary amines with carbon dioxide and lower heat of reaction of the tertiary amines. A mixture of AMP and MEA has been found to possess high absorption capacity, high absorption rates, good selectivity, and increased resistance to corrosion and degradation, when compared to the conventional amines [80].

#### 1-3. Ammonia

An aqueous ammonia solution has been shown to have significant advantages over the conventional amines including lower solvent costs, high absorption loadings, and less energy requirements for the solvent regeneration. However, the vapor pressure of ammonia is much higher, leading to significant solvent losses. Additional efforts are required to prevent or reduce the loss of solvent by cleanup, which increases the capital cost. However, it has been shown that ammonia escape can be controlled by adding some organic additives [83]. This technology is expected to become commercialized soon [84,85]. Significant improvements in the cost of electricity (COE) and CO<sub>2</sub> avoidance cost have been shown by using aqueous ammonia in a coal fired power plant, when compared to the MEA solution of 30% by weight [85]. Another advantage of ammonia is that it can be used to remove SO<sub>x</sub>, NO<sub>x</sub> and mercury from flue gas along with CO<sub>2</sub> capture. The higher capacity of aqueous ammonia found in the above studies is due to its favorable reaction towards bicarbonates over carbamates formulation.

Various ammonia based absorption processes are available, including the chilled ammonia process (Alstom Corp.), ECO2 process (Powerspan Corp.), the ammonia process developed by KIER-

KAIST (Korea), and the CSIRP process (CSIRO-Delta Electricity). These designs are based on the same absorption/desorption concept, but they differ in operating conditions (e.g., lean solvent concentration, temperatures of the liquid and gas streams, pressure). All these processes have relative advantages and disadvantages and their detailed descriptions can be found elsewhere [86,87].

Absorption of CO<sub>2</sub> in ammonia carbonate takes place near 20 °C in the so-called Alstom ammonia process; operation at this low temperature is favored as it prevents ammonia loss with cleaned flue gas. Energy requirement by this process for the regeneration of the solvent is significantly reduced as compared to the conventional MEA process and this contributes to the lower overall cost of the process. Being a proprietary process, little of its cost and performance data have been revealed for comparisons with other processes. The Powerspan ECO<sub>2</sub> capture process also uses ammonium carbonate for CO<sub>2</sub> capture, but this process operates at a higher temperature [1].

#### 1-4. Potassium Carbonate

Aqueous solution of potassium carbonate can be used for both post-combustion [88] and pre-combustion [89] carbon dioxide capture. A number of investigators have shown the solubility of CO<sub>2</sub> in aqueous potassium carbonate, at a relatively slow reaction rate and low regeneration energy requirements [88-91]. When 0.6 m piperazine was used as an additive in 20 wt% potassium carbonate, the equilibrium partial pressure was decreased by approximately 85% at the intermediate loadings and the rate of absorption was increased by an order of magnitude. The heat of absorption also increases from 15.54 to 42 kJ/mol, and capacity is comparable with other amines [90]. Addition of MEA in small quantities increased the overall absorption rate of CO<sub>2</sub> in potassium carbonate by more than an order of magnitude [88].

#### 1-5. Comparison

A brief comparison of the performance of the various chemical solvents, in terms of absorption capacity, absorption/reaction rates, and reaction enthalpy, is given in Table 1. MEA is the reference solvent for this comparison. PZ possesses almost twice higher absorption capacity for CO<sub>2</sub>, twice faster absorption rates and ~15%

**Table 1. Comparison of the performance of the various chemical solvents (amines, mixed amines and ammonia)**

| Solvent         | Absorption capacity<br>(mol CO <sub>2</sub> /kg amine+water) | Absorption rates (mol/s Pa m <sup>2</sup> )                            | Reaction enthalpy<br>(kJ/mol CO <sub>2</sub> ) |
|-----------------|--|--|--|
| MEA             | 0.47 [18]  | 4.3E-7 [18]  | 82 [18]  |
| Piperazine (PZ) | 0.79 [18]  | 2 to 3 times faster than MEA, 8.5E-7 [18]                              | 70 [18]  |
| N-methyl PZ     | 0.83 [18]  | 8.4E-7 [18]  | 67 [18]  |
| 2-methyl PZ     | 0.93 [18]  | 5.9E-7 [18]  | 72 [18]  |
| DEA             | 0.7 [19]   | Slow kinetics [19]   | 76.3 [19]                                      |
| DGA             | 0.38 [18] (10 to 20% less than MEA)                          | 3.6E-7 [18]  | 81 [18]  |
| MAPA            | 0.42 [18] (10 to 20% less than MEA)                          | 3.1E-7 [18]  | 84 [18]  |
| AMP             | 0.96 [18]  | 2.4E-7 [18]  | 73 [18]  |
| EDA             | 0.72 [279]   | 2 Times slower than MEA [279]  | 84 [279]                                       |
| MEA+PZ          | Higher than MEA  | Up to 2.5 times higher than MEA [280]                                  | Lower than MEA [280]                           |
| MEA+MDEA        | Higher than MEA [17]   | Acceptable rates [17]  | Lower than MEA [17]                            |
| MDEA+PZ         | 0.99 [18]  | 8.3E-7 [18]  | 70 [18]  |
| Aq. Ammonia     | 1.2 [281]  | Overall mass transfer coefficient 1.5 to 2 Times smaller than MEA [21] | 75% Less than MEA [281]                        |

less energy requirements as compared to MEA. Therefore, PZ is generally used as a blend with other amines. Blends of MDEA+PZ are found to give one of the highest absorption rates, and more than 15% less energy requirement. MDEA+PZ blend seems to possess excellent properties among all the amines and blends of amines. AMP has more than twice higher absorption capacity for CO<sub>2</sub>, almost 44% slower absorption rates, and about 10% less energy penalty for the solvent regeneration. Aqueous ammonia has found to possess the highest absorption rates among all the solvents given in Table 1, relatively fast kinetics, and to have a significant reduction in the energy penalty. However, due to much high vapor pressure of ammonia, a significant capital cost may be added for the process of cleaning up the solvent to avoid ammonia loss.

## 2. Applications of Process Systems Engineering (PSE) Concepts and Tools

### 2-1. Modeling and Simulations

Models of varying accuracy and complexity have been proposed, ranging from equilibrium based models to rate based models with enhancement factors and those with reaction kinetics in the bulk and liquid films. These models along with the researchers who proposed them are summarized in Table 2 and Table 3. Accuracy and complexity increase as we move from equilibrium based stages to rate based stages and from equilibrium reactions to bulk phase reaction kinetics (as in the enhancement factor approach) [92-103] or both the bulk phase and film reaction kinetics [91,104-109].

Mass transfer resistance and the effect of chemical reactions on the mass transfer can be taken into account accurately by adopting a rate based model. Separate balance equations for gas phase and liquid phase enable the modeler to take into account actual rates of mass and heat fluxes at the interface. In a rigorous rate based model, process hydrodynamics can be coupled with the mass transfer/reac-

tion phenomena by using correlations for holdups, pressure drops, mass transfer coefficients, interfacial areas, etc [105]. Such a model can be useful in optimizing scaled up designs [105]. On the other hand, these correlations are not reliable when they are applied to reacting systems, multi-component systems, and operating conditions outside of those used to develop these correlations [110]. Some of the proposed rate based models use a so-called enhancement factor. Here the enhancement of mass transfer due to reactions in the liquid film is represented by introducing an empirical factor, i.e., by assuming a pseudo-first-order reaction based on the Danckwerts approximation. These models give temperature profiles, concentration profiles, and partial pressure profiles of the entire column for both the film and bulk regions. They have been validated by comparison with published experimental data, and the validation showed good predictive capabilities in most cases.

Equilibrium based models where leaving streams of each stage are assumed to be in thermodynamic equilibrium are much simpler than the rigorous rate based models. An equilibrium based model will not contain the information of mass transfer and chemical kinetics directly. Height of a single stage is represented by 'height equivalent to theoretical plate (HETP)' and the height of the column can be obtained by multiplying it with the total number of equilibrium stages. In reality, equilibrium is seldom achieved for the stages. Hence, an equilibrium based model is oftentimes modified by using the term "tray efficiency," and all the properties including the hydrodynamics are lumped into this single parameter. However, an equilibrium based model has been shown to be quite accurate at times [111]. When an equilibrium based model was compared with a rate based model, some differences were seen in the steady state values, but dynamic responses were found to be surprisingly similar [107]. Since a stripper is operating at a high temperature, equilibrium based and

**Table 2. Steady state models for chemical absorption of carbon dioxide using MEA available in literature**

| Model used              | Description  | Modeling/Simulation environment | Solvent                                      | Reference |
|-------------------------|--|---------------------------------|--|-----------|
| Rate based model        | Mass transfer due to reactions in both bulk liquid phase and liquid film, specific features of electrolyte species | Aspen Custom Modeler®           | Amine  | [104]     |
| Rate based model        | Mass transfer due to reactions in both bulk liquid phase and liquid film, specific features of electrolyte species | DAE Solver Speed Up®            | Ammonia                                      | [105]     |
| Rate based model        | Pandya's procedure   | FORTRAN 90                      | AMP  | [282]     |
| Rate based model        | RateSep™ absorber model  | Aspen Plus®                     | MEA  | [106]     |
| Rate based model        | RateSep™ complete model of absorption/regeneration system  | Aspen Plus®                     | MEA, Ammonia, K <sub>2</sub> CO <sub>3</sub> | [91]      |
| Rate based model        | Enhancement factor approach  | -                               | MEA, DEA                                     | [93]      |
| Rate based model        | Enhancement factor approach  | -                               | MEA  | [94]      |
| Rate based model        | Enhancement factor approach  | Matlab                          | MEA  | [96]      |
| Rate based model        | Aspen Properties through CAPE-OPEN   | gPROMS                          | MEA  | [114]     |
| Rate based model        | Enhancement factor approach  | Matlab                          | MEA  | [97]      |
| Rate based model        | Enhancement factor approach, properties from Multiflash, Aspen Properties  | gPROMS                          | MEA  | [98]      |
| Equilibrium based model | Efficiency is used to remove discrepancies   | GAMS and CONOPT                 | MEA  | [121]     |
| Rate based model        | RateFrac™ absorber/stripper model  | Aspen Plus®                     | MEA  | [283]     |
| Rate based model        | -  | Aspen Plus®                     | MEA  | [284]     |

**Table 3. Dynamic models for Chemical absorption of carbon dioxide using MEA available in literature**

| Model used                           | Description  | Modeling/Simulation environment   | Solvent             | Reference |
|--------------------------------------|--|-----------------------------------|---------------------|-----------|
| Rate based model                     | Enhancement factor approach  | Matlab                            | MEA                 | [92]      |
| Rate based model                     | Mass transfer due to reactions in both bulk liquid phase and liquid film, specific features of electrolyte species | DAE Solver Speed Up <sup>®</sup>  | Ammonia             | [105]     |
| Equilibrium based & rate based model | Aspen Properties through CAPE-OPEN   | gPROMS                            | MEA                 | [107]     |
| Rate based model                     | Aspen Properties through CAPE-OPEN   | gPROMS                            | MEA                 | [108,109] |
| Rate based model                     | Enhancement factor approach  | gPROMS                            | MEA                 | [95]      |
| Rate based model                     | Enhancement factor approach  | Matlab                            | MEA                 | [96]      |
| Rate based model                     | Aspen Properties through CAPE-OPEN   | gPROMS                            | MEA                 | [114]     |
| Rate based model                     | Enhancement factor approach  | gPROMS                            | MEA                 | [97]      |
| Rate based model                     | Enhancement factor approach  | Aspen Custom Modeler <sup>®</sup> | MEA                 | [99]      |
| Rate based model                     | Enhancement factor approach  | Matlab/Simulink                   | MEA, DEA, MDEA, AMP | [100]     |
| Rate based model                     | Enhancement factor approach, properties from Multiflash, Aspen Properties  | gPROMS                            | MEA                 | [98]      |
| Rate based model                     | SAFT-VR EOS implemented in gPROMS for properties, MPC controller   | gPROMS                            | MEA                 | [112]     |
| Rate based model                     | SAFT-VR EOS implemented in gPROMS for properties   | gPROMS                            | MEA                 | [113]     |
| Rate based model                     | Reduced model based on enhancement factor approach was used. NMPC control  | Modelica                          | MEA                 | [101,102] |
| Rate based model                     | Self optimizing control, MPC   | UniSim Process Simulator          | MEA                 | [143,144] |
| Rate based model                     | Enhancement factor approach, Controllability issues using MPC  | Matlab                            | MEA                 | [285]     |
| Rate based model                     | Enhancement factor approach  | Matlab                            | MEA                 | [286]     |

rate based models give very similar desorption performance predictions [94].

Steady state chemical absorption models for MEA, AMP, DEA, DGA, DIPA, MDEA, PZ, TEA, NH<sub>3</sub>, and K<sub>2</sub>CO<sub>3</sub> are available in Aspen Plus and have been used by various researchers. The Electrolyte NRTL model has been used for calculating the VLE and other physiochemical properties. In [112,113], the SAFT-VR equation of state was implemented in gPROMS in developing a dynamic model. While some authors [98,107,108,114] used Aspen Properties via CAPE-OPEN for the property calculations, implementations of the dynamic process models were done in gPROMS. Performance of a capture plant has been evaluated with respect to height of packing in the absorber and different concentrations of the solvent, using a steady state model developed in gPROMS by [109]. Process Systems Enterprise [115] is developing a whole chain of CCS modeling tools named as gCCS using the gSAFT physical properties package for PC, IGCC Oxyfuel and NGCC power plants. Major features of these tools include high-fidelity models (equilibrium and rate based modeling), flowsheeting environment, steady state and dynamic simulation, and powerful solution capabilities via optimization.

Sensitivity of the model performance with respect to choice of physiochemical correlations has been reported by [96]. Heat loss to the surroundings was accounted for in this study. It has been shown that both equilibrium and rate based models predicted the behavior of the absorption process accurately [116]. It was suggested to use the rate based model for medium-high flow rates, however, because

the experimental data were more accurately predicted by this model. Sensitivity to choice of mass transfer correlations was also evaluated in this study. Recently, an equilibrium based model implemented in Aspen Plus was used to develop a novel ammonia based process, which can operate at the normal temperature and atmospheric pressure [86]. Simulation results showed that regeneration energy penalty can be reduced to 1.285 MJ/kg CO<sub>2</sub> and energy penalty for ammonia recovery was found to be 1.703 MJ/kg CO<sub>2</sub>. No additional energy for refrigeration is required since the process operates at room temperature. Hence the overall energy penalty was found to be less than that of the conventional MEA based process. Simulations in Aspen Plus for a chilled ammonia process integrated with a power plant have shown reduction in regeneration energy penalty, cost of electricity and CO<sub>2</sub> avoidance cost, as compared to the MEA based capture process [117].

## 2-2. Process Optimization and Integration

Various researchers have performed sensitivity analyses and optimizations to find optimal operating conditions with respect to the calculated operating and capital costs [118,119]. A number of variables have been shown to strongly affect the performance of the capture process, e.g., lean solvent loading, stripper pressure, L/G ratio, and lean solvent temperature. Unfortunately, these optimization efforts have shown that there is no economical way to reduce the reboiler energy requirement by more than 10% [118]. Process optimization has also been used to study the trade-off between the CO<sub>2</sub> capture efficiency and the operating cost. In [120], a mathe-

mathematical optimization algorithm was used to optimize a varying ratio of above-mentioned objective functions. Using an equilibrium based model, an optimization model was formulated to find the best operating conditions with respect to two different objective functions: the ratio between the total absorbed CO<sub>2</sub> and the total heating and cooling utilities, and the ratio between the total captured CO<sub>2</sub> and the total solvent flow rate [121]. In this study, we considered temperature, compositions, and flow rates of the solvent and flue gas streams together with the reboiler and condenser duties as the optimization variables.

Carbon capture efficiency of 90% is generally assumed, but Rao and Rubin [122] identified the most cost-effective level of CO<sub>2</sub> capture for an amine based process in a PC power plant utilizing an integrated modeling framework (IECM). The objective function used in this study was the cost of CO<sub>2</sub> avoided, which reflects the cost of reducing CO<sub>2</sub> emissions to the atmosphere while producing the same amount of power from a reference plant without CCS, as shown in the equation below. A tradeoff between total amount of CO<sub>2</sub> avoided and increase in the cost of electricity (COE) as compared to the reference plant is required. The relationship between the cost and capture level was found to be nonlinear. The optimal capture level was found to be not 90%; it was found to be a function of power plant size, ranging between 81% and 87% for 1,000 and 650 MW power plant sizes, respectively. It was also shown that cost-effectiveness of carbon capture can be improved by bypassing a portion of the flue gas and by treating only a portion of it at high capture efficiency.

Cost of CO<sub>2</sub> avoided (\$/tonne)

$$= \frac{(\text{COE}(\$/\text{kWh}))_{\text{ccs}} - (\text{COE}(\$/\text{kWh}))_{\text{ref}}}{(\text{CO}_2 \text{ emissions}(\text{tCO}_2/\text{kWh}))_{\text{ccs}} - (\text{CO}_2 \text{ emissions}(\text{tCO}_2/\text{kWh}))_{\text{ref}}}$$

In their next paper [123], they evaluated the effects of a number of factors, including variations in capital cost and fluctuation in prices of natural gas, variations in plant size, variations in quality of fuel such as bituminous, sub-bituminous and lignite coals. In another study [124], IECM has been used to investigate COE and CO<sub>2</sub> avoided cost; the effect of interest rates and plant life was analyzed for different CO<sub>2</sub> capture levels (85%, 90% and 95%). An optimization and parametric study for CO<sub>2</sub> capture with MEA from flue gas of 600 MW power plant was conducted using Aspen Plus [125]. The objective of this optimization study was to minimize the energy penalty for solvent regeneration with respect to various factors like CO<sub>2</sub> removal level, MEA concentration, lean solvent loading, stripper operating pressure, and lean solvent temperature. Lean solvent loading, amine solvent concentration, and stripper operating pressure were found to be important optimization variables. Recently, overall cost optimization study was performed using GAMS and the influences of different CO<sub>2</sub> emission reduction targets on the total annual cost, operating conditions, and dimensions of process units were investigated [126]. The total cost was shown to possess an approximately linear relationship with CO<sub>2</sub> removal target between 70% and 80%, while it increased exponentially for that between 80% and 95%.

Various process configurations including split flow configuration [127,128], vapor recompression [127,129], internal exchange of stripper [128], double stripper column [128,130], multipressure

stripper column [127-132], vacuum stripper column [131], flashing feed stripper [128], multistage flash [132] and compressor integration [127] have been studied and improvements in terms of the operating cost have been reported. Double pressure and multipressure column configurations have been found to be the most promising configurations for the MEA process. For the double column integration scheme, about 45% reduction in the reboiler energy requirement was achieved, whereas this figure was even lower at 54% for the multipressure column integration scheme [130]. However, in terms of equivalent work per unit time, the reductions were lower at 25.3 and 13.7% for the double pressure and multipressure column schemes, respectively. In another study [127], 28.2% reduction in the reboiler energy consumption and 6.25% reduction in the equivalent work were reported for the multipressure configuration, whereas total investment increased by 6.4%. The result also depends on the lean loading of carbon dioxide in the solvent recycled to the absorber. It has been found that use of a vacuum stripper is an attractive option for solvents with enthalpy of absorption less than 88 kJ/mol of CO<sub>2</sub>, while the multipressure stripper is favored for solvents having values of enthalpy of absorption greater than 88 kJ/mol of CO<sub>2</sub> [131].

In [128], performances of different alternative configurations have been ranked as double column>internal exchange>multipressure with split feed>flashing feed and the best solvent-configuration pair was found to be MDEA/PZ with the double pressure configuration, which gave 22% overall energy savings over the simple configuration. A three-stage flash configuration utilizing solar energy was found to reduce energy by 6% relative to the simple stripper configuration and optimally locating the intercooled stage can reduce 13% packing height [119]. In another study [127], different configurations were studied, including a split stream configuration, a multipressure stripper configuration, a vapor recompression configuration, and a compressor integration; it was shown that the vapor recompression configuration was the best choice because it gave the lowest total capture cost and CO<sub>2</sub> avoidance cost. For the vapor recompression configuration, complexity of the process does not increase very much.

In assessing the economics of these processes, important parameters are the operating cost, capital cost, and interest rate. Hence, the optimal choice of configuration can change with plant location, interest rate, energy and material costs, and plant complexity [127]. In addition, in comparing the various configurations, the degrees of freedom, e.g., lean solvent loadings, rich loadings, split fractions, stripper pressure(s), approach temperature in cross heat exchangers, need to be optimized separately for each configuration.

### 2-3. Control/Operation

Accurate and predictable steady state models are important for design and optimization purposes. On the other hand, dynamic models are required when information on operational challenges (transient conditions during start-ups, shut-downs and partial-load operations of the plant to match with grid demands) is desired. Various units of modern power plants are tightly integrated and their interactions strongly influence the operation of the process. For example, the exhaust gas flow rate changes due to the load variations in the upstream power plant; such variations in the exhaust gas flow rate can cause operating problems in the CO<sub>2</sub> capture plant. Hence, changes in the power plant's operating conditions will affect the operation

of the CO<sub>2</sub> capture plant, and vice versa. A dynamic model should allow the user to investigate the effect of various disturbances, to introduce advancements, to design and test a control system, and to perform optimization and state estimation [96].

Because experimental data from dynamic operations of capture plants are mostly lacking, validation of a dynamic model can be a challenge. As a first step, most of the authors compared steady state predictions from a dynamic model with the experimental data available in the literature. Recently, a dynamic model validation was performed with plant data logs from the University of Texas at Austin for three cases (the conventional process, and two cases with absorber intercooling) [114]. After comparison of the absorber temperature profile, capture level and reboiler duty, it was observed the model reasonably predicts the dynamic behavior of the pilot plant under multiple process inputs and disturbances. Also, higher water content had a negligible effect on the capture level, but significantly affected the temperature profile; therefore, water content was considered as an important parameter for dynamic validation. In another study [99], inlet temperatures of the flue gas and lean solvent were changed and validated against experimental data from CO<sub>2</sub>SEPPL test rig located at the Dürrohr power station.

A number of dynamic models and some control strategies of the amine-based chemical absorption process have been presented [95-102,107,108,112,113,133-144]. Dynamic behavior of the absorber has been studied in the presence of load variations [95,107], disturbances from the stripper [107], start-ups [95], and step changes in key variables, e.g., the reboiler duty [108,138], flue gas concentration [108], lean solvent rate, lean solvent loading [140], inlet flue gas flow [140], CO<sub>2</sub> concentrations, water concentrations, and CO<sub>2</sub> removal targets [140]. Dynamics of the capture system were investigated by [109] with respect to decreasing power plant output and increasing capture level varying from 90% to 95%. When the capture plant was integrated with the power plant, the dynamics of the absorption plant was found to be slower than the power plant response. Dynamic behavior of the capture plant during startups was studied, and the operation of the absorber column under varying operating conditions in the up-stream power plant and the downstream stripping column was investigated [96]. In another study [100], the dynamic behavior, absorption performance, and effect of the L/G ratio on the CO<sub>2</sub> absorption efficiency were investigated for four different solvents (MEA, DEA, MDEA and AMP). The dynamic performance of the capture system was investigated in presence of disturbance in the flow rate of flue gas and duty of the reboiler [98]. Changes in the flue gas flow rate and reboiler duty were found to significantly affect the lean loading, L/G ratio, and CO<sub>2</sub> removal efficiency. Lean loading is an important parameter for maintaining viable operation of the capture system. Very recently, [113] found the optimum value of CO<sub>2</sub> capture to be 95%. Sensible heat of solvent was found to contribute significantly to the energy penalty in the solvent regeneration, and this part of the energy penalty can be reduced through efficient heat integration and waste heat utilization. In this paper, we performed an optimization study, as opposed to a parametric study, using a validated dynamic model of a capture system, considering the cost associated with CO<sub>2</sub> capture vs. the cost associated with CO<sub>2</sub> emission.

In situations where the demand fluctuates considerably in the power supply network, advanced control systems can be important

tools for the power plant with a carbon capture system. In these cases, minimizing the energy penalty for the capture system is the main task for the advanced control system [101]. A dynamic model used for the control system design should predict the influence of disturbances from the power plant up-stream on the capture plant's operation, when the power plant is operating under varying load conditions. In addition, it should predict the influences of the units of the capture plant on one another. Furthermore, when a dynamic model is to be used directly inside a real-time optimizer or an optimization based controller (e.g., a model predictive controller (MPC)), the model should be computationally feasible (must be solvable in fractions of real-time). For this type of advanced control, simpler models are preferred and a trade-off between complexity of the model and its prediction accuracy may be needed. For this, in addition to the simplification of the process, use of simpler physiochemical property models can further simplify the overall model. In two consecutive papers [101,102], complexity reduction of an absorption model was addressed and the resulting reduced-complexity model was found to be ten-times faster with reasonable accuracy [101]. The model was formulated and solved [102] for use in nonlinear model predictive control (NMPC) in Modelica platform.

Absorber operation can be controlled during load variations by manipulating the L/G ratio to the absorber, as performance and operating conditions of the absorber are known to be much sensitive to the L/G ratio and lean solvent loading of CO<sub>2</sub> [107]. Best choices of controlled variables were identified by using the self-optimizing control approach [143,144]. Plant-wide control procedure discussed in this study consists of two parts: "a top-down analysis to optimize the process for various disturbances and identify primary self-optimizing controlled variables" [143], and "a bottom-up analysis to identify secondary controlled variables and find the structure of the control system (pairing)" [144]. In their previous paper [141], the control structure was designed using the self-optimizing control method for a fixed rate of 90% CO<sub>2</sub> removal with the objective of minimizing the energy penalty. In [143], carbon tax on the CO<sub>2</sub> emission was considered in order to obtain an optimal trade-off between CO<sub>2</sub> removal and energy requirement. In their last paper, dynamic simulations are used to validate the proposed control structures. For this, various control structures using decentralized controllers and model predictive controllers (MPCs) were considered [144]. A multi-level MPC structure (a low-level and a high-level) was proposed and developed for an amine based CO<sub>2</sub> capture system [112]. The low-level control regulated the solvent level inside the reboiler and the energy input to the system, whereas the high-level control regulated the extent of the solvent regeneration to minimize the energy requirements. It was concluded that, with the proposed control structure, safe operation could be guaranteed along with enhanced process flexibility. Up to 10% reduction in the regeneration energy cost was found to be possible with this technique. The low-level control was found to give good performance as compared to the control structure based on independent PIDs controllers. The MPC controller was found to deal with the multivariable interactions and constraints successfully and with enhanced flexibility.

Certain aspects of flexible operation of power plants need to be further investigated, including quick start-ups/shutdowns, quick changes in the output, effective operation at partial loads, increase in the maximum output, decrease in the minimum output, the ability to use dif-

ferent fuels, and the bypass to allow continued operation during fault conditions. Chemical absorption models for CO<sub>2</sub> capture are generally very complex, and therefore their simulations often run slower than those for the real time [139]. Models should strike a balance between accuracy and computational feasibility for use in control and online optimization, especially if they are to be used in real-time optimization and control.

## PHYSICAL ABSORPTION

Absorption of a solute molecule into a liquid solvent depends on the partial pressure of the solute in the gas phase. Physical absorption of acid gases (CO<sub>2</sub>+H<sub>2</sub>S) gives good performance when acid gases have high partial pressure. Hence physical absorption can be used for pre-combustion acid gases capture, as in an IGCC power plant. Physical absorption is a well-established process that has been used commercially for decades to remove acid gas from natural gas and to remove CO<sub>2</sub> from syngas (fuel gas) in the production of hydrogen, ammonia and methanol [13], but has not been used in IGCC power plants [7].

Absorption capacity of a physical solvent can be higher than that of a chemical solvent, since there is no stoichiometric limit as in the case of a chemical solvent [61]. Hence the circulation rate of a physical solvent may be less, mainly at a high acid gas partial pressure. Low temperature and high pressure are favorable for absorption in a physical solvent. The main problem with physical solvents is that it is necessary to cool the syngas before carbon capture, because they possess best capacity at low temperatures. Therefore, in the situation of pre-combustion capture in an IGCC power plant, cooling and then reheating of the stream before the gas turbine decreases the plant's thermal efficiency and thus increases the overall cost.

Since solubility depends both on temperature and pressure, an absorption-desorption process can be realized by temperature swings or pressure swings. Regeneration can be done by flash regeneration

with one or more flash stages, stripping with inert gas, e.g., nitrogen, thermal regeneration, or a combination of these methods. Generally, selective (separate H<sub>2</sub>S and CO<sub>2</sub>) or non-selective (combined H<sub>2</sub>S and CO<sub>2</sub>) configurations of these physical solvent processes may be used [24]. As compared to chemical absorption, physical absorption relies on weaker interactions between the solvent and the absorbed gas; hence, the regeneration energy requirements are usually much less. If a new solvent that can absorb CO<sub>2</sub> at higher temperatures can be developed, one could design the temperature swing process without cooling the gas stream to release the absorbed CO<sub>2</sub> at a higher pressure, thus reducing the energy penalty for the CO<sub>2</sub> compression and reheating of the fuel gas after the capture [145]. This would significantly improve the efficiency of IGCC when the carbon capture is needed. This benefit can be evaluated against the energy required for thermal regeneration and the stability of solvent at high temperature for regeneration [145]. If there is significant amount of H<sub>2</sub>S present, thermal regeneration may be required to achieve the complete stripping of the solvent.

The performance of physical solvent processes can be enhanced by the improvements such as: the development of a solvent that has acceptable capacity (high CO<sub>2</sub> loading) at a higher temperature, modifying the regeneration conditions to remove the CO<sub>2</sub> at a higher pressure, and improving the selectivity to reduce H<sub>2</sub> and other hydrocarbon losses [12]. Other desirable solvent properties include thermal stability to prevent degradation under thermal regeneration conditions, low vapor pressure to prevent or minimize solvent losses, low viscosity to lower the pumping cost, absence of unnecessary byproducts, and high regeneration efficiency [146]. Physical solvents require just carbon steel constructions because of their non-corrosive properties. Since synthesis gases do not contain significant amounts of hydrocarbons, physical solvents are suitable for the syngas treating.

### 1. Physical Solvents

Physical absorption technologies that could be applied to pre-combustion CO<sub>2</sub> capture include Selexol™ (dimethylether of poly-

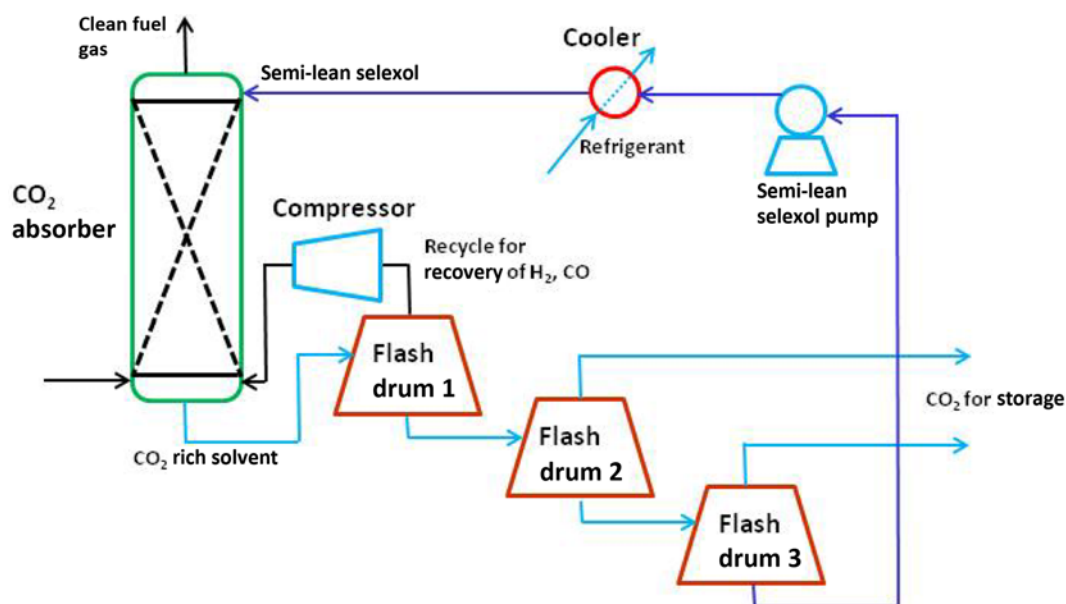

Fig. 6. Schematic diagram of the selexol™ process for a simultaneous removal of H<sub>2</sub>S & CO<sub>2</sub> (modified from Abass A. Olajire, 2010 [13]).

ethylene glycol), Rectisol® (methanol), glycol carbonate with high CO<sub>2</sub> selectivity and low capacity, Fluor (propylene carbonate), Purisol (N-methyl-2-pyrrolidone) and Sulfolane (2,3,4,5-tetrahydrothiophene-1,1-dioxide). Mixed physical and chemical solvents attempt to combine the attractive qualities of the two solvent types under special conditions. The best known mixed solvents for this purpose are Sulfinol (mixture of physical solvent Sulfolane and chemical solvent amines, e.g., MDEA, DIPA) and Amisol (mixture of physical solvent methanol and chemical solvent secondary amines) [61]. As said, the solvent can be regenerated by any of pressure reduction, inert gas stripping, and thermal regeneration.

#### 1-1. Selexol™

The Selexol™ solvent by Union Carbide is a physical solvent based on dimethylether polyethylene glycol [CH<sub>3</sub>(CH<sub>2</sub>CH<sub>2</sub>O)<sub>n</sub>CH<sub>3</sub>]; where n is between 3 and 9. The Selexol™ solvent based process is capable of capturing simultaneously (as in Fig. 6) or selectively (as in Fig. 7) H<sub>2</sub>S and CO<sub>2</sub> at higher concentrations. However, CO<sub>2</sub> is typically released at a low pressure near the atmospheric pressure and thus it requires compression to a higher pressure for transportation and storage.

For selective capturing of H<sub>2</sub>S and CO<sub>2</sub>, generally two stages for H<sub>2</sub>S and CO<sub>2</sub> are used as shown in Fig. 7. In the first absorber, the syngas enters and H<sub>2</sub>S is captured using a CO<sub>2</sub> rich solvent coming

from the CO<sub>2</sub> absorber. Exit gas from the H<sub>2</sub>S absorber enters the second absorber where CO<sub>2</sub> is removed using the lean solvent. The treated clean fuel gas from the CO<sub>2</sub> absorber is sent to the combined cycle gas turbine. The exit solvent from the CO<sub>2</sub> absorber is divided into two streams, one of which is sent to the H<sub>2</sub>S absorber and the other to a series of flash drums for regeneration. Since CO<sub>2</sub> is recovered from a series of flash drums at different pressure levels, the compression energy required for CO<sub>2</sub> is less as compared to in post-combustion capture [7]. Exit solvent from the H<sub>2</sub>S absorber, which is rich in both H<sub>2</sub>S/CO<sub>2</sub>, is sent to a stripper where the absorbed gases are released by heating in a reboiler. The first stage (sometimes the second stage as well) of the flash regeneration is operated at a high pressure and is used to recover absorbed H<sub>2</sub> and CO [147].

The Selexol™ solvent is non-reactive with the gas being treated and hence there is no formation of heat stable salts, which degrade the amine-based systems [147]. The Selexol™ solvent has a high viscosity, especially at low temperatures. The high viscosity decreases the mass transfer rates and thus increases the packing requirements. The operating temperature is usually kept low to increase the acid gas solubility and reduce the circulation rate, but this could be a disadvantage due to the higher viscosity at lower temperatures. Since the vapor pressure of the Selexol™ solvent is very low, no water

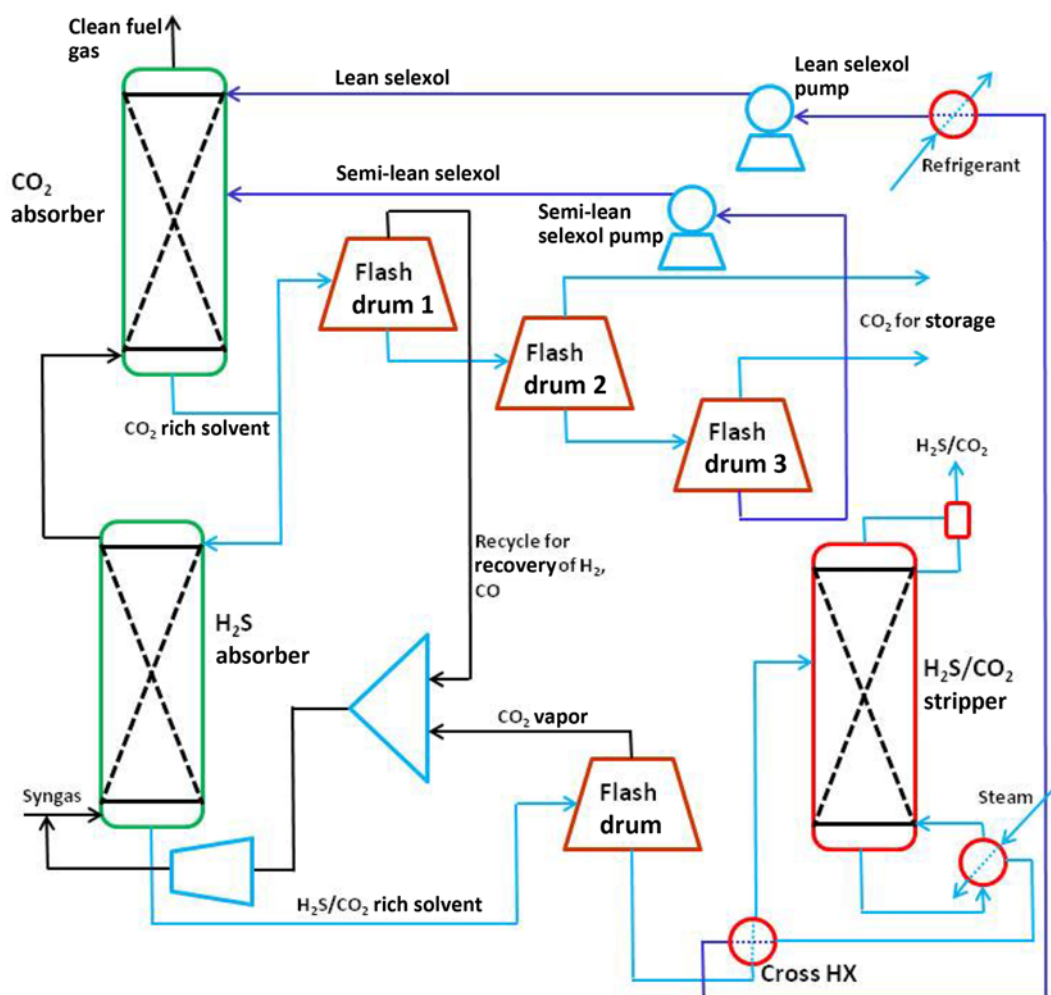

Fig. 7. Schematic diagram of the Selexol™ process for a selective removal of H<sub>2</sub>S & CO<sub>2</sub> (modified from DOE/NETL, 2010 [7]).

wash is required to recover the solvent. Operation of the Selexol™ solvent is suitable up to 175 °C and the minimum operating temperature is usually -18 °C [24]. Other advantages of Selexol™ solvent include high chemical and thermal stability, nontoxic, non-corrosive, non-foaming, and low regeneration energy requirements.

1-2. Rectisol®  
The rectisol process is based on methanol solvent which works under low temperature conditions. This too can be used for a simultaneous or selective removal of H<sub>2</sub>S and CO<sub>2</sub>. The operating temperature of the Rectisol® process is typically low (-40 to -80 °F) because of its high vapor pressure. Special recovery methods are required to prevent high solvent losses. Due to the low temperature operation, stainless steel can be used for constructing the Rectisol®, which accounts for 5% of the total materials [148]. Water washing is generally used to recover the methanol. The process is well suited where only negligible quantities of hydrocarbons syngas are present in the treated stream. The methanol solvent is widely available and cheap. This process is being used for CO<sub>2</sub> capture at the Dakota Gasification Company's natural gas plant, which is designed for the removal of approximately 1.5 million tons of CO<sub>2</sub> per year from syngas [7]. The Rectisol® process is very flexible, and therefore a number of different process configurations are possible. On the other hand, the Rectisol® process is much more complex than most other physical solvent processes. For example, it needs refrigeration due to the low temperature operation; hence, it is an expensive process.

The Rectisol® process for a selective removal of H<sub>2</sub>S and CO<sub>2</sub> is shown in Fig. 8. The feed gas is cooled with clean syngas and CO<sub>2</sub> product. Then, the condensed methanol is separated in a drum and the feed gas is sent to the CO<sub>2</sub> absorber. In the lower section of the CO<sub>2</sub> absorber, H<sub>2</sub>S is completely removed while CO<sub>2</sub> is removed in the upper part. Since the solubility of CO<sub>2</sub> in methanol is less than

that of H<sub>2</sub>S, the methanol flow in the CO<sub>2</sub> removal section is more than in the H<sub>2</sub>S removal section. The additional methanol is removed from the middle of the column, which contains only CO<sub>2</sub>, while the methanol leaving at the bottom of the absorber contains both CO<sub>2</sub> and H<sub>2</sub>S. The absorbed CO<sub>2</sub> is removed at an intermediate pressure by low pressure N<sub>2</sub> stripping in two columns. H<sub>2</sub>S is removed in a stripper by thermal regeneration. The water wash column is used for the methanol recovery from the CO<sub>2</sub> product and finally methanol is recovered from water in a methanol recovery column. Some of the process configurations and their descriptions can be found in [24,149,150].

1-3. Fluor

The Fluor solvent process, which is based on the physical solvent of propylene carbonate (C<sub>4</sub>H<sub>6</sub>O<sub>3</sub>), is suitable where the feed gas has a higher partial pressure of CO<sub>2</sub> and contains negligible or no H<sub>2</sub>S. This process is especially useful when loss of hydrocarbons and hydrogen in syngas needs to be avoided; therefore, it is suitable for pre-combustion carbon dioxide capture. Fluor solvent is a polar solvent that has a high affinity for CO<sub>2</sub> [13]. Solvent regeneration is achieved by pressure reduction because of the weaker bonding between CO<sub>2</sub> and Fluor solvent; however, high efficiency gas-liquid contactors are required [151]. The low solubility of hydrogen present in syngas translates into (1) reduction in the compression energy for the recycling of the gas flashed from the first stage of rich solvent at an intermediate pressure; and (2) reduction in fuel gas losses in the CO<sub>2</sub> vent gas stream. The intermediate pressure absorber to remove CO<sub>2</sub> is a recent improvement, which greatly reduces the amount of the recycle gas to be recompressed, and thus reduces the operating cost and hydrogen losses [152]. Feed gas chilling can further reduce the absorption of hydrocarbons and increase the solvent's CO<sub>2</sub> absorption capacity, which results in the reduction of solvent

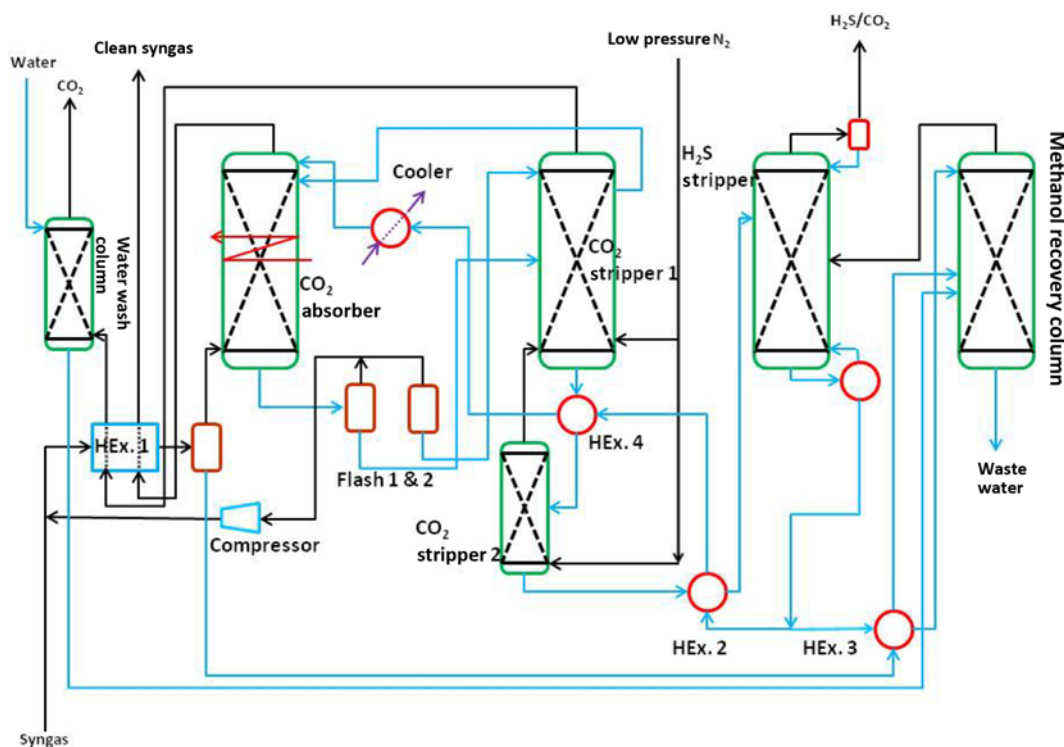

Fig. 8. Schematic diagram of rectisol® process for selective removal of H<sub>2</sub>S & CO<sub>2</sub> (modified form of Linde's AG process [183]).

circulation rate as well as in the plant cost [153].

At low temperatures, the Fluor solvent shows good mass transfer performance because it does not become too viscous [24]. Thermal regeneration is not possible for the Fluor solvent because it becomes unstable at high temperatures. High temperature stripping is required to completely remove H<sub>2</sub>S from the rich solvent. Hence the Fluor process is suitable only where H<sub>2</sub>S is 50 ppmv and improved vacuum stripping configuration should be used [24]. Fluor solvent has a higher vapor pressure as compared to DEPG; however, solvent losses are low and therefore water wash is not required. The solvent reacts with water and CO<sub>2</sub> near 90 °C [24]. The operating temperature of this process is less than 65 °C with the minimum of -18 °C [24]; therefore its process configuration is very similar to the Selexol<sup>TM</sup> process.

#### 1-4. Purisol

The Purisol process is based on the physical solvent, N-methyl-2-pyrrolidone (NMP) and it has higher selectivity for H<sub>2</sub>S over CO<sub>2</sub> than all other physical solvents [154]. Hence, it is suitable for selective removal of acid gases from syngas. It is generally used where most of the CO<sub>2</sub> needs to stay in the fuel gas for NOx control in the gas turbine [155]. The process configuration used for this solvent is very similar to that of the Selexol<sup>TM</sup> process. The absorption operation can be conducted either at an ambient temperature or at a sub-ambient temperature with refrigeration down to about -15 °C. This solvent has a higher vapor pressure than DEPG or PC, and a water wash is required for fuel gas and acid gas streams in the solvent recovery. Solvent recovery is not required when the process is operated at a sub-ambient temperature [154].

#### 1-5. Mixed Physical/Chemical Solvents

Mixed physical and chemical solvents attempt to combine the attractive qualities of the two solvent types under special conditions. The most important mixed solvents based processes are Sulfinol and Amisol [61]. The Sulfinol solvent is a mixture of a physical solvent Sulfolane and an amine-based chemical solvent. Generally, MDEA and DIPA amine based chemical solvents are used in this mixture. In Shell's Sulfinol process, a physical solvent Sulfolane and a chemical solvent DIPA mixed with 15% water are used. In its further development, Shell used MDEA instead of DIPA. The main advantage of Sulfinol is that it tolerates a much higher acid gas loading without becoming corrosive [156]. The Amisol process is based on a mixture of a physical solvent as methanol and a

**Table 4. Solubilities of gases in physical solvents relative to CO<sub>2</sub> [155]**

| Gas component    | DEPG at<br>25 °C | PC at<br>25 °C | NMP at<br>25 °C | MeOH at<br>25 °C |
|------------------|------------------|----------------|-----------------|------------------|
| Hydrogen         | 0.013            | 0.0078         | 0.0064          | 0.0054           |
| Nitrogen         | 0.020            | 0.0084         | -               | 0.012            |
| Oxygen           | -                | 0.026          | 0.035           | 0.020            |
| Carbon monoxide  | 0.028            | 0.021          | 0.021           | 0.020            |
| Carbon dioxide   | 1                | 1              | 1               | 1                |
| Hydrogen sulfide | 8.82             | 3.29           | 10.2            | 7.06             |
| Water            | 730              | 300            | 4000            | -                |

chemical solvent of either MEA or DEA, with a small amount of water. Another combination that is suitable for removal of large quantities of CO<sub>2</sub> uses MDEA instead of MEA or DEA [157]. However, there is no significant study regarding mixed physical and chemical solvents in open literature.

#### 1-6. Comparisons

Selexol<sup>TM</sup>, Rectisol<sup>®</sup>, and Purisol solvents are more selective for H<sub>2</sub>S over CO<sub>2</sub> and for CO<sub>2</sub> over other components than Fluor as shown in Table 4. Also, the Fluor solvent is unstable at temperature of 93 °C and therefore it is not suitable for selective H<sub>2</sub>S, which requires high temperature stripping to completely strip H<sub>2</sub>S from the rich solvent. The Fluor solvent can be used for selective H<sub>2</sub>S removal, if H<sub>2</sub>S is present in trace amounts [22]. The Fluor solvent process with improved stripping can be used for a removal of H<sub>2</sub>S from 200 ppmv to 4 ppmv [24].

Viscosity of the Selexol<sup>TM</sup> solvent is the highest and thus the process requires larger pumping power for solvent circulations, while the viscosity of Rectisol<sup>®</sup> solvent is the lowest among the studied physical solvents, as shown in Table 5. However, the vapor pressure of the Rectisol<sup>®</sup> solvent is much higher, and it requires refrigeration as the absorption must occur at a low temperature to avoid solvent loss. Additional energy is consumed in the Rectisol<sup>®</sup> process for heating before the cleaned syngas is sent to the gas turbine. The operating range for the Selexol<sup>TM</sup> process is larger as compared to the other physical solvents. The solubility of CO<sub>2</sub> does not vary much with the choice of physical solvents. On the other hand, the solubility of H<sub>2</sub>S in the Purisol solvent is more than three-times larger

**Table 5. Properties of physical solvent [23]**

| Solvent  | DEPG                                 | PC            | NMP     | MeOH                  |
|--|--------------------------------------|---------------|---------|-----------------------|
| Process name   | Selexol <sup>TM</sup> or coastal AGR | Fluor solvent | Purisol | Rectisol <sup>®</sup> |
| Viscosity at 25 °C (cP)                                      | 5.8                                  | 3.0           | 1.65    | 0.6                   |
| Specific gravity at 25 °C (kg/m <sup>3</sup> )               | 1030                                 | 1195          | 1027    | 785                   |
| Molecular weight   | 280                                  | 102           | 99      | 32                    |
| Vapor pressure at 25 °C (Pascal)                             | 0.0973                               | 11.332        | 53.329  | 16 665.298            |
| Freezing point (°C)  | -28                                  | -48           | -24     | -92                   |
| Boiling point at mmHg (°C)                                   | 275                                  | 240           | 202     | 65                    |
| Thermal conductivity (watt/meter/K)                          | 0.1902                               | 0.2075        | 0.1643  | 0.211                 |
| Maximum operating temperature (°C)                           | 175                                  | 65            | -       | -                     |
| Specific heat at 25 °C                                       | 0.49                                 | 0.339         | 0.4     | 0.566                 |
| CO <sub>2</sub> solubility (m <sup>3</sup> /US gal) at 25 °C | 0.01373                              | 0.01288       | 0.01351 | 0.01203               |

than in the Fluor solvent as shown in Table 4.

Advantages of the Rectisol<sup>®</sup> solvent include absorption capacity 9.7 times larger than NMP [149], high selectivity towards acid gases as shown in Table 4, less regeneration energy consumption due to its low boiling point, low viscosity, and excellent thermal and chemical stability.

## 2. Application of PSE Concepts and Tools

Since all the physical solvents discussed in this section are proprietary solvents, one does not find significant data in the open literature. Hence, only few papers can be mentioned with regard to applications of process systems engineering concepts and tools to physical absorption processes. Most of these papers are about carbon capture as a part of an IGCC power plant [74,158-163], where little information is given on the modeling/simulation of the carbon capture part. However, a few of them [24,149,150,164] include significant details for process configurations, simulations, and optimization. In addition, absorption models for Selexol<sup>™</sup>, Rectisol<sup>®</sup>, Purisol and Fluor solvent are available in commercially available software Aspen Plus.

Available literature studies include comparisons of different solvents and process configurations, and the details are discussed here. A simple solvent comparison study in terms of acid gas removal ability, equipment required and power consumptions has been conducted using the process simulation program ProMax<sup>®</sup> [24]. The study showed that Rectisol<sup>®</sup> process requires the least circulation rate and least net power, but involves more equipment than other solvent processes. The single stage and two stage process configurations for Rectisol<sup>®</sup> process have been simulated in Aspen Plus and comparison has been made in terms of capture ability, heat recovery, equipment requirement, power consumptions, and environment emissions/cost [149]. According to this study, the single stage configuration is preferred since it gives 2.4 times higher CO<sub>2</sub> recovery and consumes only about one-third of the refrigeration energy as compared to two-stage configuration. Performance of CO<sub>2</sub> removal from crude synthetic natural gas (SNG) has been studied by process simulations in Aspen Plus for the Selexol<sup>™</sup> process. In terms of energy consumption and CO<sub>2</sub> removal ability, the best performance was found at 20 bar pressure [164]. The performance of different solvents (MDEA, Selexol<sup>™</sup>, Rectisol<sup>®</sup> and Purisol) has been investigated in Aspen Plus, and the Selexol<sup>™</sup> solvent based process was found to be the best in terms of energy efficiency for pre-combustion carbon capture at the IGCC power plant feed conditions [150].

Techno-economic performance characteristics of four different capture technologies (physical absorption using Selexol<sup>™</sup>, a water-gas-shift reactor membrane, an IGCC integrated with a single stage chemical looping combustion (CLC), and an IGCC integrated with a two stage CLC) have been studied using the process simulator package called ECLIPSE, and the membrane based capture system was found to be the best [158]. Process simulations using Aspen Plus and GateCycle have been performed to compare the conventional physical absorption capture and CLC for pre-combustion carbon capture at an IGCC plant [74]. The CLC based pre-combustion capture was found to be more efficient than the conventional pre-combustion capture using physical absorption, as 100% capture was shown to be possible for the former.

Physical and chemical absorption processes as a part of an IGCC

power plant were modeled in Aspen Plus. After an initial selection based on the energy performance, three processes were selected for further study, which were Selexol<sup>™</sup>, Rectisol<sup>®</sup> and MDEA, and the Rectisol<sup>®</sup> process was found to be the most promising option for an advanced high pressure IGCC power plant [159]. In some other studies involving the Selexol<sup>™</sup> process as a part of an IGCC [160,163], the effect of the capture level on the energy performance was analyzed and the optimal level of CO<sub>2</sub> capture was found to be ~85 to 90% [163]. A solvent comparison study in an IGCC power plant using Selexol<sup>™</sup>, Rectisol<sup>®</sup> and MDEA has been performed; the main focus was on the evaluation of energy integration options [161]. A stochastic model [162] of an IGCC employing the Selexol<sup>™</sup> process was used to evaluate the effect of uncertainties in key process and cost parameters. In this study, we also investigated the effect of capture efficiency on the power requirements, efficiency, capital cost, cost of electricity (COE), and CO<sub>2</sub> avoidance cost. The lowest CO<sub>2</sub> avoidance cost was obtained at the 90% capture level.

## ADSORPTION

An adsorption process is basically composed of two steps, adsorption and regeneration, which operate on a repeated cycle. In the adsorption step, the gas stream is fed to a bed of solid adsorbent, which adsorbs CO<sub>2</sub> selectively until equilibrium is reached. An adsorption process possesses a number of advantages over the conventional absorption process including: low regeneration energy requirements, no liquid waste (the solid waste can be disposed with less environmental concern), and a much wider range of possible operating temperature (typically ranging from ambient temperature to 700 °C) [165]. The adsorption process for CO<sub>2</sub> capture has not been commercialized yet, but it is expected to play a major role in CO<sub>2</sub> capture if adsorbents with improved capacity, selectivity, and stability can be found. Adsorption processes can be categorized in terms of adsorbent bed types and process configurations as fixed bed, moving bed, and fluidized beds.

### 1. Physical Adsorption

Physical adsorption uses the affinity of CO<sub>2</sub> to material surfaces. No chemical bond is formed; instead, it relies on the weak van der Waals forces. CO<sub>2</sub> can be separated by solid adsorbents that attract it preferentially from a stream of gases at a high pressure. Highly selective adsorbent materials can capture CO<sub>2</sub> even in small concentrations. Chemical potential of CO<sub>2</sub> is higher in the solid phase as compared to the gas phase, and the adsorbent materials are capable of reversing the chemical potential of the solute gas component in the solid phase to release CO<sub>2</sub>. The chemical potential can be reversed either by changing the pressure or by stripping with inert gas or steam. Adsorption depends on the operating temperature and pressure, surface forces, and adsorbent pore size. Adsorption capacity increases with higher partial pressure of CO<sub>2</sub> and lower temperature. Low regeneration energy requirement and low time for regeneration, as it often can be done with pressure swings, are the main advantages of physical adsorption. Physical adsorbents offer the potential advantage of low heat of adsorption of CO<sub>2</sub>. On the other hand, high selectivity materials for CO<sub>2</sub>/N<sub>2</sub> are required. In addition, most physical adsorbents prefer H<sub>2</sub>O adsorption over CO<sub>2</sub> adsorption [166], and therefore, flue gas must be dried before being brought into contact with the physical adsorbent.

## 2. Chemical Adsorption

Chemical adsorption, as opposed to physical absorption, involves gas molecules forming chemical bonds with the surface of the adsorbent to form surface compounds, in a reversible reaction. The direction of the chemical reaction can be reversed in the regeneration step, generally performed at a high temperature. Regeneration by changing the temperature can potentially improve the efficiency if the temperature change needed is not too large [61]. On the other hand, the temperature swing may require a longer cycle time due to the heat capacity of the adsorbent material.

Dry regenerable solid sorbents are typically considered for CO<sub>2</sub> capture from flue gas in a chemical adsorption process. Chemicals such as amines, sodium carbonates, and potassium carbonates can be immobilized on the surface of solid support to create a solid regenerable sorbent. High surface area support materials used for this purpose include alumina or silica, while chemicals such as alkali carbonates react with CO<sub>2</sub> and water to form alkali bicarbonate. Another example is polyethylenimine (PEI) sorbent, which is a novel nanoporous polymer supported amine sorbent, called molecular basket sorbent (MBS). These structures offer a number of potential advantages including high sorption capacity and selectivity for CO<sub>2</sub>, high sorption/desorption rates, good regenerability and stability during the sorption/desorption cycles, low energy consumption, special functionality, promoting effect of moisture in the gas on sorption capacity (as presence of water in the feed is necessary for the formation of bicarbonate), and almost no or reduced corrosion [166]. They are typically implemented in a TSA process, producing pure CO<sub>2</sub>/water product which can be separated further via cooling and compression. Heat recovery from a solid adsorbent is more difficult than that from a liquid solvent, however, a fact that diminishes the heat capacity advantage of solid sorbents compared to the liquid amines. Chemical adsorbents typically have high heat of reaction with CO<sub>2</sub>.

## 3. Regeneration Techniques

The adsorbent material can be regenerated by using one of the following techniques: pressure swing adsorption (PSA), vacuum swing adsorption (VSA), hybrid vacuum-pressure swing adsorption (VPSA), temperature swing adsorption (TSA), electric swing adsorption (ESA), hybrid pressure-temperature swing adsorption (PTSA) and hybrid vacuum-temperature swing adsorption (VTSA). PSA and TSA have been used in H<sub>2</sub> production, O<sub>2</sub> separation, and CO<sub>2</sub> removal from natural gas, but not in large scale power plants. Significant literature is available in a review [32] for temperature and vacuum swing adsorbents including zeolites, carbon molecular sieves, metal organic frameworks, microporous polymers, and amine-modified sorbents.

### 3-1. Pressure Swing and Vacuum Swing Adsorption

PSA and VSA are attractive options given the low power consumption, fast regeneration, and simple operation [167,168]. They are used in most of the commercial adsorption applications. However, the main drawback in post-combustion CO<sub>2</sub> capture is the cooling and drying requirements of flue gas. In some cases, removal of SO<sub>x</sub> in order to avoid poisoning of the adsorbents is also required. Presence of water may lower the performance of the adsorbent, reducing the CO<sub>2</sub> capacity [167]. PSA is used where high purity is required as the lower vacuum level gives both high purity and recovery [169]. Various PSA and VSA cycles have been demonstrated for different cycle configurations and adsorbents.

Zeolite 13X has shown superior performance over activated carbons using the VPSA cycle, achieving purity up to 99%, and recovery rates of 53% and 70% for the low and high CO<sub>2</sub> flue gas concentrations, respectively [170]. The VSA process is a promising technology because it is highly flexible as compared to other processes in terms of cycle design, changes in fuel/flue gas conditions, targeted recovery/purity levels, and energy consumption. The effect of impurities and water in fuel/flue gas on the performance of the VSA process should be evaluated further [171].

### 3-2. Temperature Swing Adsorption

The adsorbent may also be regenerated by increasing the temperature of the adsorbent bed, and the process is called temperature swing adsorption (TSA). TSA has been evaluated for its potential in CO<sub>2</sub> capture, mainly in order to reduce the energy requirements. TSA may be applied on both physical and chemical adsorption, but water should be absent in TSA; however, water promotes the adsorption in alkali metal based adsorbents, i.e., chemical adsorption. Sensible and stripping energy requirements are lower as compared to the absorption process because large amount of water is not required to heat and cool in absorption/desorption cycle. Large energy is required to pressurize the captured CO<sub>2</sub> for transport and storage when PSA or VSA is applied as they release the CO<sub>2</sub> at low pressures [172]. In this sense, TSA and ESA can be an attractive alternative for the regeneration, but large regeneration time is the main drawback for TSA. The PSA process can regenerate the adsorbent in a few seconds, whereas TSA could take hours. Hence lowering the cycle time by lowering the heat capacity or increasing the cooling rate, e.g., through the use of adsorbents on hollow fibers, is one of the challenges. The main drawbacks of TSA are low productivity (large amount of adsorbent is required) and dilution of the desorbed gas by the addition of purge gas. By using indirect heating using internal heat exchanger, a TSA process may be designed to avoid these drawbacks [173,174]. Advantages of using purge gas are increased desorption rate as a result of the CO<sub>2</sub> component being pushed out and increased heat transfer coefficient, which in turn reduces the regeneration time [175].

### 3-3. Electric Swing Adsorption

In electric swing adsorption (ESA), the adsorbent is regenerated by passing a low-voltage electric current. The ESA process proposed in [157] requires less energy than other regeneration processes, but this process is not commercially ready yet. In the ESA process, carbon fiber composite molecular sieve (CFCMS) is used [157]. CO<sub>2</sub> adsorption from syngas has been tested by using the ESA process utilizing CFCMS with a monolithic structure; the regeneration is performed by applying low voltage across the carbon fiber adsorbent. In the ESA process, an activated honeycomb monolith is used to achieve high recovery (89%) with only 16% purity [31]. Due to low CO<sub>2</sub> adsorption capacity of activated carbon and an additional step of product rinsing to increase the purity is required, the authors suggested exploring an alternative adsorbent.

### 3-4. Hybrid Pressure and Temperature Swing Adsorption

A hybrid PTSA process has been studied by Tokyo Electric Power Company (TEPCO) and Mitsubishi Heavy Industries [176] using high capacity/selectivity adsorbent zeolite Ca-X( $\beta$ ). The study reported 11% reduction in the power consumption as compared with the conventional PSA. In another study for post-combustion capture, the purity of 99% and recovery of 90% were achieved using zeolites;

however, the energy penalty was high at 5.6 MJ/kg CO<sub>2</sub> [177].

#### 4. Types of Solid Sorbents

Adsorption is a surface phenomenon, in which atoms, ions, or molecules (it could be gas, liquid or dissolved solid) stick to the adsorbent surface. On the other hand, absorption is a bulk phenomenon (as it involves the entire volume of the absorbing substance) in which a fluid is dissolved by a liquid or a solid (absorbent). Solid sorbents can be classified into adsorbents (physical adsorption) and absorbents (chemical adsorption/dry absorption). Various solid sorbents have been proposed for removal of CO<sub>2</sub> from fuel/flue gas including carbonaceous materials/activated carbon, zeolite molecular sieves, and metal organic frameworks (MOFs) materials, which are adsorbents; and lithium zirconate, lithium silicate, sodium carbonate, potassium carbonate, amine supported sorbents, and metal oxides, which are absorbents.

The desirable features of the sorbent material are a high surface area to volume ratio, low energy requirements for adsorbent regeneration, low regeneration time, high adsorption capacity, resistance to attrition over multiple regeneration cycles, high selectivity, good performance at the high temperatures encountered in IGCC power plants, low cost raw materials, thermal and chemical stability, and low heat capacity.

##### 4-1. Physical Sorbents

###### 4-1-1. Molecular Sieve Adsorbent/Zeolites

Zeolites are specially designed and arranged molecular sieves with uniform-sized pores of molecular dimensions that are capable of separating molecules based on the difference of molecular weight or size. Zeolite materials are known to possess good adsorption properties, provide flexibility in operation, and be cost effective [178]. These materials can produce pure CO<sub>2</sub>, but they come with high energy penalties for vacuum pumps and dehumidifiers [33]. Some studies have shown high selectivity of certain zeolites at high temperatures (450-700 °C) for CO<sub>2</sub> capture. Experimental studies have shown the benefits of zeolite 5A and 13X over silica gel for CO<sub>2</sub> capture [37].

###### 4-1-2. Activated Carbon

Activated carbon materials have high surface areas and high CO<sub>2</sub> adsorption capacity. They are also water-resistant and cheaper than zeolites, and they can be easily formed into different shapes (monolith, bead, fiber, granular) [179]. Activated carbon can be used for both post-combustion [180] and pre-combustion [181] capture of CO<sub>2</sub>. A commercially activated carbon (Norit R2030CO2) has been tested for post-combustion capture and it has been shown to possess sufficient CO<sub>2</sub>/N<sub>2</sub> selectivity with maximum recovery of 97% [180]. This commercial adsorbent, when used for pre-combustion capture, has given maximum CO<sub>2</sub> capture capacity of 3.96 mol/kg adsorbent and breakthrough time of 10.50 minutes [181]. It has been shown that activated carbons possess lower adsorption capacity than zeolites at low pressures, but this is actually reversed at higher pressures [182]. The good fluidization properties, and minimum dust formation/attrition losses during the adsorption and regeneration (achieved by using spherical beads), can make this material a preferable choice over the zeolites [179]. Adsorption equilibrium and kinetics of CO<sub>2</sub> in activated carbon beads have been studied over a wide range of temperature and pressure [179].

###### 4-1-3. Molecular Organic Frameworks (MOFs)

Metal organic frameworks (MOFs) are emerging microporous

crystalline structures and are lately receiving much attention for use in post-combustion CO<sub>2</sub> capture. MOFs are 3-D structures formed by central metal cations with well-defined coordination geometry linked together by organic molecules (ligands) holding void spaces. The void spaces in such a structure can be used to adsorb large amounts of CO<sub>2</sub> with low energy penalty and cost [14]. Due to their ability to form various configurations based on the types of cation and organic molecules, a large number of MOFs can be synthesized. Therefore, important parameters such as pore size and topography can be easily tuned by selection of various combinations of cation and organic molecules. Presence of water vapor can damage their structure and impurities in flue gas can radically reduce the capacity of MOFs [184]. Adsorption capacity of MOFs decreases at high temperature, and also at low partial pressure of CO<sub>2</sub> it becomes lower as compared to zeolites and activated carbon [185]. However, at higher partial pressure of CO<sub>2</sub> their adsorption capacity was observed to be larger than zeolites and activated carbons [186]. It was reported that a container filled with MOF-177 at 35 bar can capture nine-times the amount of CO<sub>2</sub> when compared to a container without adsorbent, and about two-times the amount compared to that filled with zeolite or activated carbon [186]. These materials hold great potential for future applications in CO<sub>2</sub> capture; however, some major challenges such as high cost of materials and lack of experimental data for complete adsorption/desorption cycles limit their large-scale adoption at current time [184].

##### 4-2. Chemical Sorbents

Regenerable solid sorbent based processes hold high promise for being cost effective and energy efficient. They also can be used for the post-combustion CO<sub>2</sub> capture in existing coal-fired plants and be easily integrated into new power generation facilities. Sorbent materials like alkali metal carbonates are suitable for use in the coal-fired power plants, incorporating wet flue gas desulfurization, as sorption phenomena are enhanced by water present in the flue gas. Significant research efforts have been devoted to the development of this type of process by a number of worldwide research institutes, including the DOE/NETL, RTI, LSU in USA, the KNU, KEPRI, KIER in Korea, and the Southeast University in China [187]. The sorbents can be classified as natural sorbents (CaCO<sub>3</sub>, NaHCO<sub>3</sub>, MgCO<sub>3</sub>), which come with fast reaction kinetics and cheap prices; synthetic sorbents (LiZrO<sub>3</sub>, LiSiO<sub>4</sub>, K<sub>2</sub>CO<sub>3</sub>), which generally give slower carbonation kinetics and higher production costs but much longer durability [188]. The sorbents can also be classified as high calcination temperature sorbents (CaCO<sub>3</sub>, 930 °C) and low temperature sorbents (NaHCO<sub>3</sub>, 120-170 °C, K<sub>2</sub>CO<sub>3</sub>, 70-140 °C) [188]. High temperature sorbents are more suitable for heat integration of the capture process with the power plant cycle. These sorbents require support, for which various materials like Al<sub>2</sub>O<sub>3</sub>, activated carbons, TiO<sub>2</sub>, MgO, ZrO, and SiO<sub>2</sub> have been examined [189-192].

###### 4-2-1. Lithium Based Sorbents

Lithium zirconate [193-195] and lithium silicate [196-205] have been studied and found to be favorable for CO<sub>2</sub> capture since absorption based on these materials can be operated as TSA and the operating temperature can be made much nearer to the syngas temperature. Note that the phenomenon here is one of solid absorption as it occurs beyond the surface of the solid lithium compounds, which are typically prepared in the pallet form. On the other hand, many previous review papers have categorized them as adsorbents, perhaps

because they are used as solid beds in the process. In this paper, we chose to include them in the adsorption section following this practice.

This technology is based on the following reversible chemical reaction of the absorbent with CO<sub>2</sub>:

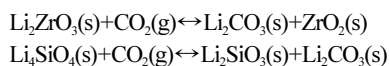

The reaction of lithium zirconate is reversible in the temperature range of 450 to 590 °C, and therefore absorbent can be regenerated using TSA. Here, the reaction accelerates the CO<sub>2</sub> absorption process. The equilibrium temperature of the lithium silicate is 720 °C [206] and absorbs CO<sub>2</sub> below this temperature and releases CO<sub>2</sub> above it. The lithium silicate based technology is a strong candidate to emerge as one of the winners among the competing CO<sub>2</sub> capture technologies, owing to its large capacity, rapid absorption rates, wide range of operating temperature and concentration of CO<sub>2</sub>, good stability, and attrition resistance. However, lithium based materials are expensive. The absorption rate in lithium silicate is roughly 30 times faster than in lithium zirconate [207], and also its absorption capacity is about four-times higher, reducing the weight of absorbent by 23% [208]. Also, the cost of raw material SiO<sub>2</sub>, required for lithium silicate, is lower than that of ZrO<sub>2</sub> for lithium zirconate [196]. This technology not only captures CO<sub>2</sub> but also promotes the water gas shift reaction and can also be used as sorbent enhanced water gas shift (SEWGS). Due to its promising properties, lithium silicate has also been considered for post-combustion capture. However, low absorption rates after some reaction time at a moderate temperature near the water gas shift temperature are a major problem.

A double shell model was proposed to represent the mechanism of CO<sub>2</sub> absorption on lithium silicate [197,209]. According to this model, the resultant molten lithium carbonate shell facilitates the CO<sub>2</sub> diffusion through the carbonate layer. Lithium carbonate and lithium metasilicate are formed when CO<sub>2</sub> diffuses to the surface of lithium silicate and reacts with Li<sup>+</sup> and O<sup>2-</sup>. Unreacted lithium silicate and lithium carbonate are then covered with a solid shell of lithium metasilicate, and also a solid shell is formed outside lithium metasilicate. For the reaction to proceed further, Li<sup>+</sup>, O<sup>2-</sup>, and CO<sub>2</sub> have to diffuse through the lithium carbonate shell. Hence, due to the continuous build-up of the product layer, the absorption rate begins to decrease. This resistance can be reduced significantly by doping potassium carbonate to lithium silicate, because lithium carbonate forms a eutectic melt with potassium carbonate and the liquid shell can decrease resistance to the CO<sub>2</sub> diffusion [194]. Synthesis methods are very important as lithium silicate materials with large surface areas should be prepared.

One of the problems with lithium silicate is the lithium sublimation as Li<sub>2</sub>O, as shown in the reaction below.

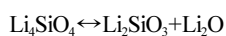

When the feed gas is supplied to the absorbent at a high temperature (>200 °C), the reaction between lithium zirconate and water does not occur [210]; this high temperature is also favorable for the absorption kinetics. Decomposition of lithium silicate did not take place at temperatures even above 900 °C; hence, there is no adverse effect of thermal decomposition [208].

Using different synthesis methods, different particles sizes of the lithium silicate absorbent can be obtained. The stability of lithium

silicate depends on particle sizes, and this happens due to the lithium sublimation, which is induced on small particles [211]. Also, particle sizes affect the kinetic parameters for the chemisorption and diffusion process [211]. Different multiple CO<sub>2</sub> absorption/desorption cycles were performed to investigate the durability. Sensitivities of CO<sub>2</sub> sorption capacity with respect to the sorption temperature, type of silica, and doping method with K<sub>2</sub>CO<sub>3</sub> have been investigated. The selected absorbent maintained its original capacity after operation of multiple absorptions/desorption cycles [212].

Reactivity of the lithium silicate with CO<sub>2</sub> can be improved by doping with metals such as aluminum or iron [212] and by using alkali carbonate promoters such as K<sub>2</sub>CO<sub>3</sub> [195]. Solid state doped lithium silicate was prepared by using different types of silica (amorphous and crystalline) and two doping methods (eutectic doping and 10 mol% K<sub>2</sub>CO<sub>3</sub>) for use in a condition of high temperature and low CO<sub>2</sub> concentration [212]. Pure lithium silicate powder was used to investigate the CO<sub>2</sub> absorption capacity by TGA (thermogravimetric analysis) and, the capacity change over multiple cycles was monitored. The absorbent's performance in terms of absorption rate and capacity was found to be improved significantly by using amorphous silica and the doping method [212].

The effect of feed rate, amount of absorbent and the suspension concentration on the CO<sub>2</sub> recovery was evaluated in a slurry bubble column using lithium silicate suspended in molten salt. This system can rapidly absorb and desorb CO<sub>2</sub> with no drop in CO<sub>2</sub> recovery with repeated cycles [213]. Lithium silicate suspended in molten salt was proposed and CO<sub>2</sub> solubility and mass transfer were investigated. The sensitivities of CO<sub>2</sub> recovery to the gas feed rate, quantity of absorbent, and suspension concentration were evaluated. It was concluded that the absorption rate was highly dependent on feed gas rate, but not on adsorbent quantity and suspension concentration. This system was found to be very promising, giving high efficiency in recovering. Nano crystalline lithium silicate prepared in micro emulsion has shown improved CO<sub>2</sub> absorption capacity and fast cycle time at high temperatures [214].

#### 4-2-2. Sodium Based Sorbents

Sodium carbonate can also be used for post-combustion CO<sub>2</sub> capture from flue gas by making use of the following reactions:

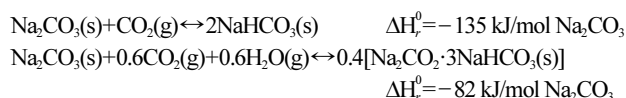

In this reaction, equal amounts of CO<sub>2</sub> and H<sub>2</sub>O in moles are produced during the regeneration step and then water is condensed to obtain relatively pure CO<sub>2</sub> for storage. Temperature ranges for CO<sub>2</sub> capture (60-70 °C) and regeneration (120-200 °C) for Na<sub>2</sub>CO<sub>3</sub> are very similar to those in the amine absorption [215]. A preliminary estimate showed that the regeneration energy needed is comparable or less than that for MEA regeneration. Laboratory studies indicate that 15% supported sodium carbonate sorbent will absorb significant quantities of CO<sub>2</sub> from simulated flue gas in a down-flow concurrent reactor system with a gas-solids contact time of approximately 15 seconds. The reaction occurs between 25 °C and 62 °C, and is favored by low temperatures and high sorbent-to-gas ratios [216].

Research Triangle Institute International (RTI) has been developing a sodium carbonate process and they have demonstrated this process on a pilot scale. Regeneration can be achieved by a tem-

perature swing of ~60 K [115]. RTI has developed and tested several types of sodium carbonate based sorbents, which are abundant and relatively cheap. Various methods of preparation have been tested to exploit the higher surface area and mechanical strength of these materials [187]. Besides sodium carbonate, sodium metazirconate  $\text{Na}_2\text{ZrO}_3$  has also been tested for sorption of  $\text{CO}_2$  in the presence of water vapor at low temperatures (30–70 °C). The theoretical  $\text{CO}_2$  absorption capacity on  $\text{Na}_2\text{ZrO}_3$  is 10.8 mol/kg, when water vapor is present in the gas stream, which is twice the capacity on sodium carbonate in dry conditions. The reaction mechanism and kinetic analysis have been studied for  $\text{Na}_2\text{ZrO}_3$  carbonation process in the presence of water [217].

In [219], a series of  $\text{Na}_2\text{CO}_3$ -based sorbents were studied by coating the  $\text{Na}_2\text{CO}_3$  material onto metal foils, with loading of  $\text{Na}_2\text{CO}_3$  on  $\text{Al}_2\text{O}_3$  in the range of 25–40 wt%. A fixed bed reactor was used to study the performance of these sorbents at various water concentrations and absorption temperatures. The performance of the sorbent coated metal foils was compared with a series of  $\text{Na}_2\text{CO}_3/\text{Al}_2\text{O}_3$  powder sorbents with same concentration of  $\text{Na}_2\text{CO}_3$  as in the case of foil samples. For most of the cases, the performance of powder based sorbent was better as compared to the foil based sorbents, but highest performance (~7.7 mol of  $\text{CO}_2/\text{kg}$  of  $\text{Na}_2\text{CO}_3$ ) was observed for the case of 35%  $\text{Na}_2\text{CO}_3/\text{Al}_2\text{O}_3$  sorbent coated on foil. The stability of the sorbent was tested for 500 cycles and found to be competitive with the existing methods [219].

#### 4-2-3. Potassium Based Sorbents

Extensive studies have been conducted using dry potassium-based sorbents in Korea (e.g., Kyungpook National University (KNU) [189-191,219-222], Korea Electric Power Research Institute (KEPRI), and Korea Institute of Energy Research (KIER)). KNU's research team has been developing various sorbent formulations, which are tested in a fixed bed reactor as powdered sorbents [189-191,219-222]. They have also tested absorption and regeneration properties of  $\text{K}_2\text{CO}_3$  and support materials such as activated carbons,  $\text{TiO}_2$ ,  $\text{Al}_2\text{O}_3$ ,  $\text{MgO}$ ,  $\text{SiO}_2$  and zeolites [189-191]. KEPRI has been working on synthesis of spherical particles for fluidized-bed reactors [223-227]. KIER has developed a capture process involving two fluidized-bed reactors [192,225-229] for testing the sorbents supplied by KEPRI.

Potassium carbonate absorbs  $\text{CO}_2$  according to the reaction:

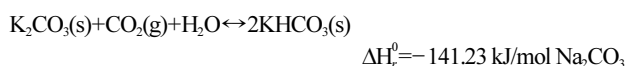

$\text{K}_2\text{CO}_3/\text{Al}_2\text{O}_3$  sorbents were tested for 60 days in a  $\text{CO}_2$  capture pilot plant built for unit 3 of Hadong thermal power station in Korea. The  $\text{SO}_x$  of 10–40 ppm in the flue gas reacted only with  $\text{K}_2\text{CO}_3$ , and not with  $\text{Al}_2\text{O}_3$ , to form  $\text{K}_2\text{SO}_4$ , which is quite stable in a wide range of temperature (i.e., 180–550 °C) [192].

Physical properties and reactivities of six potassium-based sorbents (35 wt%  $\text{K}_2\text{CO}_3$  in all sorbents) were tested to evaluate their applicability to a fluidized-bed capture process. All the sorbents have shown adequate attrition resistance and reactivity, and were regenerated almost completely at temperatures less than 140 °C [223]. They have been tested in a process composed of two fluidized-bed reactors. The effects of gas velocity, solid circulation, carbonation temperature, and water vapor content were evaluated for  $\text{CO}_2$  capture from flue gas. Carbonation temperature in the fast fluidized

reactor ranges from 70 to 90 °C.  $\text{CO}_2$  removal was found to improve with the increasing solid circulation rate and water vapor content and the decreasing gas velocity. The water vapor content in the flue gas was found to have a major effect on the overall  $\text{CO}_2$  removal [225].  $\text{K}_2\text{CO}_3$ -based sorbent with  $\alpha$ -alumina showed better regeneration properties compared to  $\text{K}_2\text{CO}_3$ -based sorbent using  $\gamma$ -alumina as support material. The reaction rate of  $\text{K}_2\text{CO}_3$  was found to be slower and the capture capacity reached only 80% of the theoretical value. The flow regime achieved in the fluidized bed was shown to have strong effects on the performance of  $\text{CO}_2$  capture. The turbulent fluidization provided a higher capacity of ~290 g  $\text{CO}_2/\text{kg}$   $\text{K}_2\text{CO}_3$  sorbent, when compared to the multiple bubbling and fast fluidization regimes, resulting in the capacities in the range of 210–230 g  $\text{CO}_2/\text{kg}$   $\text{K}_2\text{CO}_3$  sorbent [230]. Potassium based sorbent process has several advantages including good gas-liquid contact for smaller sorbent particles, ease in sorbent make-up handling, ease in control of carbonation temperature, and steady operation [223].

#### 4-2-4. Supported Amine Sorbents

Supported amine sorbents are composed of amine functional groups immobilized on or grafted onto the high surface area support. The performance of supported amine sorbents can be optimized by tuning support characteristics, amine type, and its loading. Activated carbons, zeolites, polymers, and silicas have been considered as support materials [231].

Upon contact with flue gas, supported amine sorbents chemically adsorb  $\text{CO}_2$  and water. High temperatures in the regeneration drive the reaction in the reverse direction to regenerate the amine while releasing  $\text{CO}_2$  and water. The amine surface is adequately stable to withstand the regeneration conditions. The supported amines exhibited the highest working  $\text{CO}_2$  capacities among the physical adsorbents studied for comparison with supported amine sorbents, although they can become poisoned by the presence of  $\text{SO}_2$  [232]. Silica-amine sorbent can contain large amounts of loaded amines, and a tradeoff is required between the amine loading and the remaining surface area of the support. When the pores of the support are filled with the amine,  $\text{CO}_2$  sorption capacity is large, but at the same time there is little room available within the composite for gas transport. Oxygen present in the flue gas can degrade amine-based sorbents [32].

TEPA supported silica and polymethylmethacrylate sorbents have been studied for post-combustion  $\text{CO}_2$  capture using a lab-scale circulating fluidized bed reactor. The amine loading and pore volume have significant influence on the sorbent  $\text{CO}_2$  capacity.  $\text{CO}_2$  was captured from dry flue gas with a difference of only 70 °C between the absorber and desorber temperatures (40 °C and 110 °C, respectively). High purity  $\text{CO}_2$  product above 90% was obtained [231]. High heat of  $\text{CO}_2$  absorption is required for amines and the inability of thermal exchange of many support materials can lead to increase in adverse heat effects during absorption. This in turn affects the absorption capacity of the different types of amine supported sorbents [233]. These heat effects can be avoided by employing novel support structures for efficient heat and mass transfer, as discussed in the next subsection of novel structured sorbents.

#### 4-2-5. Novel Structured Sorbents

Structured sorbent modules such as hollow fiber and monolithic sorbents can be an alternative for removing the deficiencies of the traditional fixed bed and fluidized bed configurations in both physical and chemical sorption processes. The advantages of structured

sorbents include low energy consumption, higher throughput, higher recovery and purity of product due to even flow distributions, low mass transfer resistance, and low pressure drop with reasonable sorption capacity [234]. Hollow fiber sorbents are such structured sorbent systems that can mitigate thermal effects associated with fixed bed sorption by allowing rapid heat and mass transfer; the heat transfer material can simply be steam or water [235]. Hollow polymeric fibers have been used with sorbent particles embedded in the porous fiber wall for post-combustion capture in a rapid TSA process. Cooling water is circulated during absorption to prevent temperature rise due to heat of absorption, while steam or hot water is circulated during desorption to desorb CO<sub>2</sub> rapidly. Kinetic limitations in these systems can be overcome by increasing the superficial gas velocity and fiber packing. Hollow fiber sorbent systems are well-suited for use with amine absorbents, as it has been shown using amine-polymer system (PEI) [236]. Further details of these structured sorbents can be found in the literature [237-239].

### 5. Applications of PSE Concepts and Tools

Applications of PSE concepts and tools to CO<sub>2</sub> capture using adsorption include multiscale simulations to investigate structural and physical properties of sorbent materials, modeling of adsorption isotherms, and process-level modeling for complete adsorption/desorption systems to find optimal operating conditions and cycle time.

#### 5-1. Multiscale Modeling/Simulations

Multiscale simulation, which is a powerful tool to investigate gas-solid interactions, can be used to match experiment in the design of new materials. Molecular force fields required for the Grand Canonical Monte Carlo (GCMC) simulations can be obtained either from empirical methods or from first-principles calculations. First principles force field-based GCMC calculations give significantly enhanced accuracy as well as additional information regarding the gas-solid interactions as compared to the conventional empirical force field-based GCMC methods. Whereas the lack of force field parameters for the empirical force field methods limits the study of adsorption for novel adsorbents at molecular level, multiscale simulations based on first principles or density function theory (DFT) calculations provide a general and efficient means of obtaining performance predictions. The development of accurate force field for material interactions is still a main issue in multiscale simulations. However, it is clear that use of molecular-level simulations along with experiments can significantly speed up the process of developing novel adsorbents for CO<sub>2</sub> capture [240].

Adsorption structures, adsorption energy, Gibb's free energies and bicarbonate formation rate constants of CO<sub>2</sub> and H<sub>2</sub>O adsorption on K<sub>2</sub>CO<sub>3</sub> were estimated using DFT calculations and strong adsorption of H<sub>2</sub>O as compared to CO<sub>2</sub> were predicted [241]. Molecular model based GCMC simulations were performed to investigate the structural (pore size distribution, XRD, atomic relative concentration, partial radial distribution, ring distribution, pore surface smoothness, etc.) and adsorption properties (adsorption isotherms and isosteric heats of pure N<sub>2</sub>, CO<sub>2</sub> and their mixture in flue gas) of the MCM-41. It was found that CO<sub>2</sub> adsorption behavior depends on the surface functional group while N<sub>2</sub> adsorption depends on the available pore volume. This model has been used to predict the structural and adsorption properties of novel amine (EDA, DETA, TETA, TEPA, PEHA, PEI and APTES) functionalized MCM-41 adsorbents [242]. GCMC simulations have also been used for studying adsorption of

CO<sub>2</sub> and N<sub>2</sub> in alkali metal cat-ion exchanged zeolites; the predicted adsorption isotherms and heats of adsorption data were found to be in good agreement with experimental results [243].

#### 5-2. Process-level Modeling/Simulations and Optimization

Performance analysis of an adsorption system is oftentimes confined to isotherms or pure component selectivities, but these can be poor indicators of an adsorption based capture process and can be misleading conclusions in many cases [244]. A complete process model for the adsorption/desorption cycle is required for an accurate performance evaluation.

A 1-D dynamic model of calcium looping process for post-combustion carbon capture was proposed using two interconnected fluidized bed reactors [245]. Capture efficiency and reactor temperature profiles were shown to give good agreement with experimental data from a laboratory scale test rig at INCAR-CSIR, Spain. It was found that good temperature control is necessary for the efficient operation of this plant. It was also observed that the process operation is affected by a number of parameters including the circulation ratio, fluidization conditions, cooling and heating, fuel feed, makeup flow, and solid inventory. Since the model is capable of handling hydrodynamics, reaction kinetics, and energy transfer, it can be used for scale-up studies [245]. The variable diffusivity model was used to consider the physically expanding product layer and two reacting zone, i.e., a high reactivity outer shell and a low reactivity inner core. An excellent fit with TGA experimental data at various operating conditions was found for a CO<sub>2</sub> capture process with potassium-promoted half-calcined dolomite adsorbent [246].

Rigorous rate-based and equilibrium based PSA models have been used in adsorption studies [247,248]. Simulation studies have been performed using such models, and performance has been analyzed with respect to the feed throughput, CO<sub>2</sub> purity and CO<sub>2</sub> recovery for various PSA cycle configurations over a range of process conditions. Optimal configurations and process conditions were also found. Both rigorous numerical simulations and equilibrium based theories were utilized in the analysis of [175]. Three basic PSA configurations were studied using rigorous PSA models. Activated carbon was chosen as a reference adsorbent, and the performance of this reference adsorbent was used as a bench mark in the comparison of other available adsorbents as well as newly developed ones. A sensitivity analysis for the efficiency of regeneration to non-uniform heating has been performed for 5A zeolite [249]. Temperature, loading, and CO<sub>2</sub> fluid phase mole fraction profiles were calculated. It has been shown that during the TSA regeneration cycle, strict heating controls and optimal placement/spacing of heating devices (in order that heat can be distributed evenly throughout) are required to achieve high regeneration efficiency. When the geometry of the adsorbent was altered, two times increment in the effective thermal conductivity and 55% increment in regeneration efficiency were reported [250]. Sensitivity analysis has been performed for a PSA/VSA post-combustion capture process to find the most important property parameters, providing some important insights for development of new adsorbents [244].

Amine immobilized on support materials was studied for use in fixed bed, isothermal fluidized bed, and adiabatic fluidized bed adsorption process. Fixed bed process was found to be most attractive option; the isothermal fluidized bed process can also be an attractive alternative but heat transfer can be a major challenge there [115].

A modified grain size model for CO<sub>2</sub> capture by calcium-magnesium based sorbent was proposed and a good agreement between model predictions and experimental data was observed. In that system, CaO adsorbent particles were supported on porous MgO called CGMG framework. The effect of various parameters (e.g., particle size, reaction temperature, CaO contents, and porosity) on the dynamics of CaO conversion inside the particle was evaluated [250].

A multi-objective optimization (with the objectives of CO<sub>2</sub> purity and recovery levels) was performed using the DIVPAG solver, and the results were presented as the so-called Pareto set. Various process configurations (different flow directions during depressurization steps and number of pressure equalization steps) and conditions were optimized and the Pareto sets were compared [251]. A calciner reactor model was proposed to find the calciner efficiency as a function of operating conditions such as solid inventory, calciner temperature, and solid circulation rate. It was found that typical solid inventories (8,000-12,000 mol of Ca/m<sup>2</sup>) and calciner temperature (1,173-1,183 K) gave high calciner efficiencies (95%) [252].

### MEMBRANE SEPARATION

Membranes are porous/semi-permeable materials that act as filters, and therefore can be used to separate CO<sub>2</sub> selectively from other gas components. Membrane surface permits the desired gas molecule to adsorb onto the surface of the high pressure side, and then this molecule passes through the interior of the membrane and reaches the low pressure side as shown in Fig. 9. In the conventional case, the membrane separates gas into two streams: the stream rich in CO<sub>2</sub> is called 'permeate' stream, while the clean gas stream is called 'retentate'. The pressure difference across the membrane is the driving force, and this driving force can be generated by pressurizing the gas stream on one side or by creating vacuum on the other side. Selectivity and permeability are two most important parameters determining the membrane efficiency. Selectivity, which is dependent on the material choice, determines the purity of CO<sub>2</sub> product. On

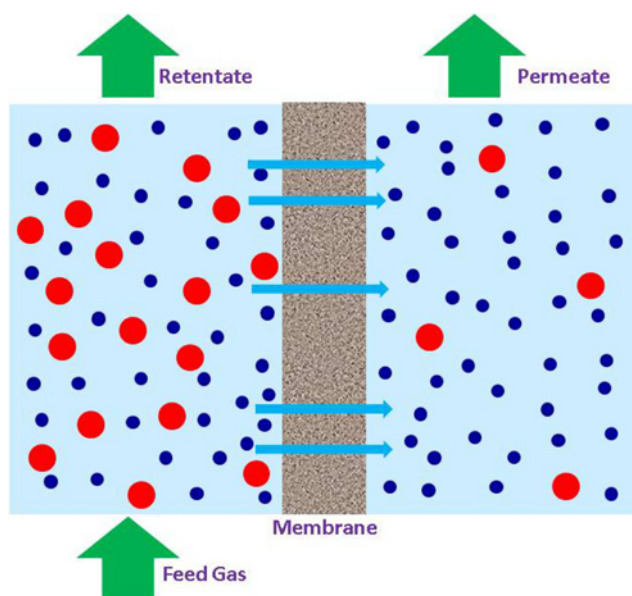

Fig. 9. Schematic of gas separation membrane.

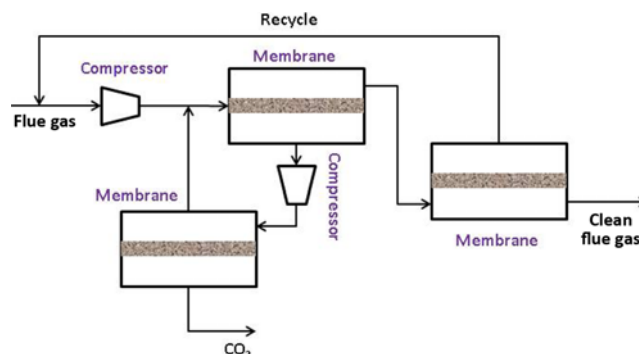

Fig. 10. Schematic of membrane separation process (modified from R. W. Baker, 2008 [278]).

the other hand, permeability reflects the flux of the transported stream and affects the membrane area required to achieve a given rate of separation. Since the selectivity of most membrane materials is such that it is not possible to achieve desired purities and recoveries in one pass, multiple stages and recycle streams are required as shown in Fig. 10. Use of multiple stages and recycles will increase the complexity of the process, energy penalty, and capital cost [7]. In addition, some tradeoff is required between recovery rate and purity.

Some studies have shown that membrane based CO<sub>2</sub> capture has the potential to offer significant reduction in energy penalty and cost as compared to the conventional amine based absorption systems. Other advantages of membranes include simple modular systems and no waste streams. However, challenges for commercialization of this technology include the various operational problems, e.g., membrane fouling, sensitivity to sulfur compounds and other trace elements, as well as scale-ups to large-scale power plant applications [1]. Since flue gas exits the power plant at low pressures, additional energy for pressurization is required to create the pressure driving force across the membrane. In the case of pre-combustion capture as in IGCC, CO<sub>2</sub> in fuel gas/syngas already has high partial pressure, and hence additional pressurization or creation of vacuum for this purpose is not required. Therefore, membrane separation may be particularly attractive for pre-combustion capture in IGCC. For effective performance of membrane separation in pre-combustion carbon capture, the membrane should not only have high permeability and selectivity for CO<sub>2</sub> but it should also be able to operate at high pressures and temperatures, which are the conditions of IGCC power plants. A vacuum or sweep gas is required on the permeate side because partial pressure of CO<sub>2</sub> in flue gas is low. Further separation is required when sweep gas is used and large energy penalty is incurred from the compression of CO<sub>2</sub> from vacuum to a high pressure for transportation and storage [12].

A number of membranes, including polymeric membranes, inorganic membranes, metallic membranes, and composite hollow fiber membranes, have been investigated. Other advanced types studied include mixed-matrix membranes (composed of polymeric matrix and inorganic zeolites), hybrid membranes (porous inorganic support material, which is surface-modified with chemicals having good affinity to CO<sub>2</sub>), and facilitated transport membranes. Membrane technology has been used at commercial scale for hydrogen recovery in ammonia synthesis, removal of CO<sub>2</sub> from natural gas, and nitrogen separation from air; however, it is yet to be used for CO<sub>2</sub>

capture in large scale power plants, and other industrial manufacturing processes requiring high purity CO<sub>2</sub> as products. Before the membrane technology can be commercialized for CO<sub>2</sub> capture in large scale power plants, much improvement is required in terms of selectivity, permeability, energy requirements, and materials stability. Combinations of different options, e.g., mixed-matrix membrane, provide some hope for future applications. In addition, combining the water gas shift reaction with membrane separation may be an excellent option for pre-combustion capture [10].

### 1. Types of Membranes

Membranes are classified on the basis of type of materials. They can be organic (polymeric membranes) or inorganic (carbon, ceramic, zeolite, metallic, etc.) and can be porous or non-porous. Membrane types for pre-combustion capture include polymeric membranes, inorganic microporous membranes, and palladium membranes [5, 7, 13, 61]. Pre-combustion capture membranes can be CO<sub>2</sub> selective or H<sub>2</sub> selective membranes.

#### 1-1. Polymeric Membranes

Polymeric membranes have been found to possess lower energy penalty and require less maintenance as compared to the pressure swing adsorption process [49, 253]. Energy penalty for polymeric membranes is significantly less as compared to conventional amine absorption, for a recovery ratio of less than 0.8 and CO<sub>2</sub> concentration of more than 0.2 mole fraction in the gas stream [254]. This level of CO<sub>2</sub> composition can be found in the cement industry, steel production, etc., but not in the post-combustion streams of power plants. Energy penalty can be reduced by producing a vacuum on the permeate side instead of compressing the feed stream [255] in post combustion capture. These membranes can also be used to separate CO<sub>2</sub> from H<sub>2</sub> in pre-combustion capture, but high temperature can destroy the membrane. Advantages of polymeric membranes include low cost, ease of synthesis, and mechanical stability [256]. The presence of water and SO<sub>2</sub> can also reduce the performance of polymeric membranes [257, 258].

Modifications of polymeric membrane can improve the CO<sub>2</sub> capture performance. One modified membrane developed in collaboration with the US DOE [259] has been claimed to give a ten-fold increase in permeability with CO<sub>2</sub>/N<sub>2</sub> selectivity of 50 at 30 °C as compared to the commercial CO<sub>2</sub> separation membranes. Optimizing polymeric composition and packing within membranes can improve the solubility and diffusion of CO<sub>2</sub>, respectively. Therefore, significant improvements in permeability and selectivity can be obtained by combining these two approaches (polymeric composition and packing within membranes) for CO<sub>2</sub> separation [13]. Thin film composite membrane named as EO-3 can achieve high recovery and purity and can be used for CO<sub>2</sub> capture from syngas and flue gas [46]. Polybenzimidazole (PBI) membranes developed at DOE's Los Alamos National Laboratory (LANL) have shown long term hydrothermal stability up to 400 °C, tolerance to sulfur compounds, and durability for over 400 days at 250 °C with reduction in the membrane thickness by less than 3 μm, when operated for CO<sub>2</sub> capture from syngas [84].

#### 1-2. Inorganic Membranes

Even though polymeric membranes are currently dominating industrial applications, significant research efforts are being devoted to the development and application of inorganic membranes owing to their demands in new fields, i.e., fuel cells, membrane reactors,

and large scale gas separations at high temperature [10]. Inorganic membranes are capable of operating at high temperatures. Inorganic membranes can be porous or non-porous. In non-porous membranes, high selectivities can be achieved. Porous metal or ceramic support can be used as a support where a thin top layer of nonporous membrane is casted. This support material provides mechanical strength with negligible mass transfer resistance. Porous membranes are cheaper but hold low selectivities. Since non-porous membranes possess low permeability, however, their applications are limited as compared to porous membranes [10]. Alumina, carbon, glass, silica, zeolite, and zirconia membranes are mainly used as porous inorganic membrane materials supported on different substrates.

Uniform-sized pores of molecular dimensions based on inorganic crystalline structures are called zeolites and also known as molecular sieves. MFI-type zeolite membranes supported on γ-alumina and stainless steel have been investigated for flue gas separation. ZSM-5 type zeolite membrane supported on porous stainless steel has been reported to give good performance with high selectivities of CO<sub>2</sub>/N<sub>2</sub> and high permeability [48]. Zeolites are very effective as shape- and size-selective materials for gas separations, because molecular size cavities and pores (0.3-1.0 nm) can be manufactured. The main advantage of zeolites for gas separation is their ability to preferentially adsorb CO<sub>2</sub> molecules by size and polarity [10]. In gas mixtures of CO<sub>2</sub>/N<sub>2</sub> and CO<sub>2</sub>/H<sub>2</sub>, CO<sub>2</sub> molecules permeate selectively because their molecular size is smaller [10].

Amorphous silica membranes are suitable for highly selective CO<sub>2</sub> separations. However, permeability is low for these membranes due to their narrow pores. Performance of silica membranes can be improved by controlling the pore size and the structure by a synthesis method [84]. Silica membranes possess good structural, chemical, and thermal stability in both oxidizing and reducing environments, and their structure can be modified easily [10].

For the mixtures of gases having similar mass such as CO<sub>2</sub>/N<sub>2</sub>, and the mixtures where the selectivity towards the heavier components is desired such as CO<sub>2</sub>/H<sub>2</sub>, alumina is not desirable membrane material due to its low selectivity. Mainly it can be used as a support material in gas separation because it possess good structural properties and, its chemical and hydrothermal stabilities beyond 1,000 °C, make it very desirable [10].

#### 1-3. Modified Membranes

In hybrid membranes or surface modified inorganic membranes, a porous inorganic support material is modified with chemicals having good affinity with CO<sub>2</sub> on the surface. These modified membranes have shown high flux and selectivity [45], as porous inorganic support materials allow large permeability and functional groups on the surface offer high selectivity. While in supported liquid membranes, CO<sub>2</sub> transport takes place through the liquid in the pores, therefore, offering the advantage of higher diffusivities in liquid phase as compared to in solid phase. In this way both selectivity and flux can be increased because porous inorganic allows large fluxes and liquid chemicals in the pores offer high selectivity [260]. These systems provide high surface area to volume ratio, resulting in a compact system. Generally, the membranes are not participating in the separation process; they only create a barrier between liquid and gaseous phases. Liquid supported membranes using ionic liquids can operate at elevated temperatures due to the very low vapor pressure of ionic liquids and excellent resistance to plasticization of poly-

mer material [53].

By incorporating a carrier agent into polymeric membrane, selectivity can be improved. CO<sub>2</sub> dissolved in the upstream part of the membrane where it reacts with the carrier agent inside the membrane and a complex is formed. This complex diffuses through the membrane and is released on the other side of the membrane, and the carrier agent is recovered as it diffuses back to the upstream side; these types of membranes are called facilitated transport membranes. The driving force for the facilitated transport membranes is the partial pressure of CO<sub>2</sub>. Carbonates, amines and molten salt hydrates can be used as the carriers for CO<sub>2</sub> separations [261]. Problems associated with the facilitated transport membranes include membrane stability and chemical volatility. By increasing the partial pressure on the feed side, flux increases while the selectivity decreases. This is due to a saturation of the carrier and increased permeation of unwanted components [5]. A facilitated transport membrane study in collaboration with US DOE [259] has shown that a membrane with CO<sub>2</sub> permeance of more than 1,000 GPU and CO<sub>2</sub>/N<sub>2</sub> selectivity of 50 has been developed. The permeance of 1,000 GPU is ten times higher than available commercial CO<sub>2</sub> membranes and the selectivity is also reasonable. These membranes in combination with a novel process design, improved process integrations, and use of sweep gas to generate driving force are expected to meet the US DOE capture cost targets [259].

Mixed-matrix membranes can show superior performance by combining the advantages of inorganic and polymeric membrane materials. However, the processability of these membranes is a challenge in many cases. Mixed-matrix of zeolites (molecular sieves) and polymeric materials can provide advantages of both processability of polymers and selectivity of zeolites [47]. Another potential problem with this membrane type is the poor contact at the interface of two materials [260]. Around the solid particles at the interface, gases may pass through non-selectively. Suitable choice of polymeric matrix and inorganic zeolite, and the removal of interface defects are the main challenges for improving their performance.

Membranes can also be used to provide contact area in an absorber, thus reducing the size of absorber and hence capital cost. It has been shown that doing so can reduce the absorber size by 72% as compared to the conventional column [262]. Operational problems including foaming, flooding, entrainment, and channeling can be avoided, thus relaxing restrictions on gas or liquid flow rates. Choice of solvent and membrane is very important. Membranes can also be used in the desorption step.

A shell and tube type membrane modification has been proposed, in which flue gas flows through a bundle of membrane tubes, while amine solution flows through the shell side [84]. CO<sub>2</sub> gets absorbed into the amine solution after passing through the membrane. Significant reduction in the amine loss can be achieved because impurities will not pass through the membrane. Then the amine solution is regenerated and recycled for further separation of CO<sub>2</sub>. Similarly, by modifying the membrane with amine functional group in the pores, selective diffusion of CO<sub>2</sub> through the pore wall can be improved, and the blockage of impurities can lead to higher selectivity and less solvent loss.

Further enhancements in the existing modification methods as well as development of new modification techniques that can improve the long-term stability and performance at elevated tempera-

tures will accelerate the commercialization [13].

## 2. Applications of PSE Concepts and Tools

PSE tools and concepts applied on membrane systems include molecular calculations [263,264], cost analysis [259,265-269], sensitivity analysis [259,265,268,270,271], uncertainty analysis [268], process integration/configuration [265,270,272], and process optimization [265,272]. Since the focus of the research in this area has been on developing membranes with high permeability and selectivity, only a small number of studies of this type are available. Most of the investigations were performed for process integrations and overall performance analysis of the power plants; however, some papers presented future improvements required in the membrane properties (permeance and selectivity) to meet the capture cost targets using sensitivity analysis.

### 2-1. Multiscale Modeling/Simulations

Metal-metal matrix membranes can be made in various possible combinations, and candidates for the most suitable combination of the metals can be identified by using a modeling approach. For this purpose, DFT calculations can be used to predict the behaviors of H<sub>2</sub> or gas mixture. These modeling studies not only predict the performance of the membranes but also suggest improvement of the poisoning resistance by introduction of additives [263]. The CO<sub>2</sub>/N<sub>2</sub> permeation from flue gas in carbon nanotube (CNT) membrane was evaluated using molecular simulations [264]. The GCMC method was used to calculate the adsorption isotherm, and much higher loading of pure CO<sub>2</sub> as compared to pure N<sub>2</sub> was found, while the similar loading was found for CO<sub>2</sub>/N<sub>2</sub> mixtures. Results of molecular dynamics have shown diffusion of N<sub>2</sub> to be faster than that of CO<sub>2</sub>. Their diffusion coefficients become identical at high concentrations due to the slowdown of the fast moving species and speed up of the slow moving species. It was suggested to consider additional functionalization of CNT such as amino functionalization based on the facilitated transport phenomenon for further improvements.

### 2-2. Process-level Modeling/Simulations

US DOE's NETL, in collaboration with various other organizations, is working on carbon capture system modeling and simulations to develop a comprehensive, integrated package of validated computational models in a virtual power plant setting. When new technologies are introduced, this initiative will reduce the risk by speeding up the development cycle and letting the user examine various optimized designs along with their confidence levels [7]. For example, a modeling study has shown that the sorption-enhanced water gas shift reaction could reduce the cost significantly for a natural gas power plant with carbon capture [50]. Performance comparisons between membranes and amine based separation for CO<sub>2</sub> capture from flue gas have been presented in several modeling studies [254, 273,274]. Since the utilization of low pressure or vacuum to increase the driving force across the membrane is very expensive, usage of sweep gas has been suggested to achieve separation without extra energy consumption. The effect of the sweep gas on the required membrane area and the degree of CO<sub>2</sub> separation was evaluated. A cost analysis showed that, with the use of sweep gas, an efficiency loss of 3.8 percent points was expected for a 600 MW reference power plant with a 70% CO<sub>2</sub> separation [269]. A preliminary cost analysis indicated that a facilitated transport membrane process can capture 90% of CO<sub>2</sub> from flue gas, using roughly 16% of the plant energy at the capture cost of \$23/t CO<sub>2</sub> [259].

Influence of different operating conditions has been evaluated for a single stage membrane treating humidified flue gas using PRO/II software [275]. A polymeric (polyvinyl amine/polyvinyl alcohol blend) facilitated transport membrane and a glassy Polybenzimidazole were used for this purpose. Sensitivity analysis has been performed with [267] and without sweep gas [265] to evaluate the effect of permeance, selectivity, and membrane cost on the capture cost. In [267], a detailed modeling and cost-sensitivity study was presented for a membrane based process using air sweep for carbon capture from flue gas. The effects of membrane parameters (selectivity and permeance) on the energy and capture costs were determined. For a scenario of low membrane module price of 27 USD/m<sup>2</sup>, CO<sub>2</sub>/N<sub>2</sub> selectivity of about 140 and high permeance of 3,000 GPU was chosen; the study estimated a 33% increase in COE and less than 24 USD/t CO<sub>2</sub> capture cost, in order to achieve 90% CO<sub>2</sub> recovery and 95% purity of CO<sub>2</sub> product [267]. Although these membrane properties used have not been achieved yet, it revealed the level of improvement needed in the properties of membrane. A sensitivity analysis was done to suggest important improvements [259]; suggested improvements included compression of the feed gas (giving less membrane areas but higher energy requirements) and use of vacuum (larger membrane areas but low energy requirements). In addition, the study claimed that future research should focus on developing membranes with higher permeance rather than higher selectivity [259]. Influences of process parameters on the energy demand and the flue gas processing cost have been evaluated for the facilitated transport membrane process for CO<sub>2</sub> capture from flue gas using Aspen Hysys [270]. It was concluded that this membrane system competes well with the amine-based absorption in terms of energy requirements.

### 2-3. Process Optimization and Integration

Process optimization using mass and energy balances has been performed for carbon capture from flue gas utilizing multi-stage membrane systems [272]. The process was optimized for minimum energy consumption for different scenarios such that recirculation of flue gas, variation of feed gas pressure, and variation of the vacuum on the permeate side. PRO/II software was used for the simulations [272]. In another study, three membrane configurations (single stage and two stage membrane systems with and without retentate recycle) were investigated by using the cross flow model [265]. The proposed system under 1.5 bar flue gas pressure and 0.08 bar permeate vacuum was shown to achieve a 35% reduction in the CO<sub>2</sub> avoidance cost compared to the pressurized feed membrane process.

In collaboration with the Energy Technology Partnership (ETP) and Scottish Power, an extensive study on modeling and simulations of membranes has been conducted [276]. The performance of membranes in terms of purity and recovery of CO<sub>2</sub> for various flow patterns and membrane module configurations was compared with a fixed membrane area and under same operating conditions. Honeywell's process flowsheet simulator UniSim Design® was used to find the optimal process in terms of purity, energy consumption and membrane area.

For a Pd/Au based membrane reactor integrated into an IGCC power plant, an economic performance model was developed and economic risks were analyzed in the presence of various uncertainties in the market and operating environment (technological and operational uncertainties) [268]. In the net present value (NPV) model,

the Monte Carlo method was used to evaluate the effect of the uncertainties on the process economic performance. This method enables the propagation of uncertain inputs to an economic model, and the process performance variable's value can be expressed as a more realistic probability distribution rather than a single point [268].

## CONCLUSION AND RECOMMENDATIONS

Efforts on carbon capture have ramped up significantly in the last few years; however, most of the technologies being developed are still at the early stages. Some carbon capture technologies, e.g. amine, Selexol™, etc., are quite mature, but their applications on large scale power generation emission sources are not cost effective, unless these technologies can be significantly improved. The amine-based absorption process is by far the most mature option and can be applied for post-combustion capture. At the present time, it is not cost effective although some improvements have been made in terms of additives, mixed solvents, alternative configurations, and process integrations.

Higher hopes are being held for some of the novel materials based technologies, e.g., adsorption, membrane separation. Modified membranes and modified adsorbents have shown the greatest future potential, but these technologies are still at early stages of development and need improvements in stability and synthesis methods. Also, demonstration plants are lacking. Readers should be cautioned that performance and cost data reported in the literature carry significant uncertainties in the case of the emerging technologies, because their fundamentals are still not fully understood and scale ups have not been verified. These uncertainties also arise from the lack of real engineering cost data, inconsistencies in the reporting of estimated cost data, and the confidentiality of industrial data.

Recommendations for future research include:

- Short-term focus should be on mixed chemical solvents, stability of membranes and adsorbents, and synthesis methods for membranes and adsorbents, whereas long-term efforts should include pilot-scale testing of modified adsorbents and membranes and commercial-scale demonstrations for these as well as alternative chemical solvents, and mixed solvents. The latter should be connected directly with power plants, in order to reduce the uncertainty in the cost analysis and to obtain necessary operational experiences.
- For oxy-fuel combustion, short-term focus should be on improving the cryogenic air separation techniques, while long-term efforts should be given to development of new air separation techniques (e.g., oxygen transport membranes).
- For chemical looping combustion, the main focus should be on improving the stability of metal oxides and developing demonstration plants.
- Significant further improvements are possible by applying various PSE concepts and tools.
  - Short-term efforts should focus on exploring opportunities for process integrations and studying operation/control issues for relatively mature technologies (e.g., chemical absorption combined with post-combustion capture in power plants; physical absorption, membranes and adsorption combined

with IGCC power plants).

- Short-term efforts should also include heat integration of the adsorption process with the power plant.
- Molecular simulation studies should continue to search for novel adsorbent materials such as MOFs and molecular sieves.
- Long-term research efforts should include modeling/simulations, optimizations, and cost analysis for new emerging technologies (modified membranes and modified adsorbents combined with post and pre-combustion power plants, and advanced energy production systems, e.g., oxy-fuel combustion and chemical looping combustions power plants) based on improved plant data.
- Additional regulations and incentives are required for initial applications of CCS technologies to large scale power generation sources to lower the investment barrier for the investors. In addition, collaborations among industry, government, environmental protection agencies and academia should be expanded so that their knowledge and experience can be shared and integrated.

### ACKNOWLEDGEMENT

This research was supported by the Basic Science Research Program through the National Research Foundation of Korea (NRF) funded by the Ministry of Education, Science and Technology (2011-0006839) and by the Advanced Biomass R&D Center (ABC) of Global Frontier Project funded by the Ministry of Education, Science and Technology (ABC-0031354) of Rep. of Korea

### REFERENCES

1. P. Folger, *Carbon capture: A technology assessment, Congressional Research Service Report, University of Nebraska - Lincoln* (2010).
2. A. B. Rao and E. S. Rubin, *Environ. Sci. Technol.*, **36**(20), 4467 (2002).
3. J. T. Houghton, Y. Ding, D. J. Griggs, M. Noguer, P. J. van der Linden, X. Dai, K. Maskel and C. A. Johnson, *Climate Change 2001: The scientific basis*, Cambridge, UK (2001).
4. *Energy Technology Perspectives 2008, Scenarios & Strategies to 2050*, IEA (2008).
5. *IPCC special report on carbon dioxide capture and storage* (2005).
6. P. H. M. Feron and C. A. Hendriks, *Oil. Gas Sci. Tech. - Rev. IFP*, **60**(3), 451 (2005).
7. *DOE/NETL carbon dioxide capture and storage RD&D roadmap, Proceedings of the Laurance Reid gas Conditioning Conference* (2010).
8. D. Aaron and C. Tsouris, *Sep. Sci. Technol.*, **40**(1-3), 321 (2005).
9. M. M. Hossain and H. I. de Lasa, *Chem. Eng. Sci.*, **63**(18), 4433 (2008).
10. H. Yang, Z. Xu, M. Fan, R. Gupta, R. B. Slimane, A. E. Bland and I. Wright, *J. Environ. Sci.*, **20**(1), 14 (2008).
11. M. R. Othman, Martunus, R. Zakaria and W. J. N. Fernando, *Energy Pol.*, **37**(5), 1718 (2009).
12. S. I. Plasynski, J. T. Litynski, H. G. McIlvried and R. D. Srivastava, *Crit. Rev. Plant Sci.*, **28**(3), 123 (2009).
13. A. A. Olajire, *Energy*, **35**(6), 2610 (2010).
14. E. S. Rubin, H. Mantripragada, A. Marks, P. Versteeg and J. Kitchin, *Prog. Energy Combust. Sci.*, **38**(5), 630 (2012).
15. R. Idem, M. Wilson, P. Tontiwachwuthikul, A. Chakma, A. Veawab, A. Aroonwilas and D. Gelowitz, *Ind. Eng. Chem. Res.*, **45**(8), 2414 (2005).
16. S. Ma'mun, J. P. Jakobsen, H. F. Svendsen and O. Juliussen, *Ind. Eng. Chem. Res.*, **45**(8), 2505 (2005).
17. N. Ramachandran, A. Aboudheir, R. Idem and P. Tontiwachwuthikul, *Ind. Eng. Chem. Res.*, **45**(8), 2608 (2006).
18. X. Chen, F. Cloosmann and G. T. Rochelle, *Energy Procedia*, **4**, 101 (2011).
19. P. Galindo, A. Schäffer, K. Brechtel, S. Unterberger and G. Scheffknecht, *Fuel*, **101**, 2 (2012).
20. D. A. Glasscock, J. E. Critchfield and G. T. Rochelle, *Chem. Eng. Sci.*, **46**(11), 2829 (1991).
21. G. Puxty, R. Rowland and M. Attalla, *Chem. Eng. Sci.*, **65**(2), 915 (2010).
22. R. W. Bucklin and R. L. Schendel, *Comparison of physical solvents used for gas processing, in acid and sour gas treating processes*, S. A. Newman, Gulf Publishing Co., Houston, TX (1985).
23. R. W. Bucklin and R. L. Schendel, *Energy Progress*, **4**(3), 137 (1984).
24. B. Barry and L. Lili, *A comparison of physical solvents for acid gas removal*, Bryan Research & Engineering, Inc., Bryan, Texas, U.S.A.
25. M. L. Gray, Y. Soong, K. J. Champagne, H. Pennline, J. P. Baltrus, R. W. Stevens Jr., R. Khatri, S. S. C. Chuang and T. Filburn, *Fuel Process. Technol.*, **86**(14-15), 1449 (2005).
26. G. P. Knowles, J. V. Graham, S. W. Delaney and A. L. Chaffee, *Fuel Process. Technol.*, **86**(14-15), 1435 (2005).
27. G. P. Knowles, S. W. Delaney and A. L. Chaffee, *Ind. Eng. Chem. Res.*, **45**(8), 2626 (2006).
28. X. Xu, C. Song, B. G. Miller and A. W. Scaroni, *Fuel Process. Technol.*, **86**(14-15), 1457 (2005).
29. H. Y. Huang, R. T. Yang, D. Chinn and C. L. Munson, *Ind. Eng. Chem. Res.*, **42**(12), 2427 (2002).
30. X. Xu, C. Song, J. M. Andresen, B. G. Miller and A. W. Scaroni, *Energ. Fuel.*, **16**(6), 1463 (2002).
31. C. A. Grande and A. E. Rodrigues, *Int. J. Greenhouse Gas Control*, **2**(2), 194 (2008).
32. N. Hedin, L. Andersson, L. Bergström and J. Yan, *Appl. Energy*, **104**, 418 (2013).
33. M. Ishibashi, K. Otake, S. Kanamori and A. Yasutake, *Study on CO<sub>2</sub> removal technology from flue gas of thermal power plant by physical adsorption method*, B. E. P. Riemer and A. Wokaun, Elsevier Science, Ltd., London (1999).
34. N. Konduru, P. Lindner and N. M. Assaf-Anid, *AIChE J.*, **53**(12), 3137 (2007).
35. J. Mérel, M. Clausse and F. Meunier, *Environ. Prog.*, **25**(4), 327 (2006).
36. B.-K. Na, K.-K. Koo, H.-M. Eum, H. Lee and H. Song, *Korean J. Chem. Eng.*, **18**(2), 220 (2001).
37. Y. Wang and M. D. LeVan, *J. Chem. Eng. Data*, **54**(10), 2839 (2009).
38. X. Xu, C. Song, J. M. Andrésen, B. G. Miller and A. W. Scaroni, *Micropor. Mesopor. Mater.*, **62**(1-2), 29 (2003).
39. H. Yoshitake, T. Yokoi and T. Tatsumi, *Chem. Mater.*, **14**(11), 4603 (2002).
40. C. E. Powell and G. G. Qiao, *J. Membr. Sci.*, **279**(1-2), 1 (2006).
41. G. Illing, K. Hellgardt, R. J. Wakeman and A. Jungbauer, *J. Membr. Sci.*, **184**(1), 69 (2001).

42. Z.-K. Xu, C. Dannenberg, J. Springer, S. Banerjee and G. Maier, *J. Membr. Sci.*, **205**(1-2), 23 (2002).
43. Ş. B. Tantekin-Ersolmaz, Ç. Atalay-Oral, M. Tatlıyer, A. Erdem-Şenatarlar, B. Schoeman and J. Sterte, *J. Membr. Sci.*, **175**(2), 285 (2000).
44. S. Husain and W. J. Koros, *J. Membr. Sci.*, **288**(1-2), 195 (2007).
45. D. Luebke, C. Myers and H. Pennline, *Energy Fuels*, **20**(5), 1906 (2006).
46. S. Li, Z. Wang, C. Zhang, M. Wang, F. Yuan, J. Wang and S. Wang, *J. Membr. Sci.*, **436**, 121 (2013).
47. M. Nomura, T. Yamaguchi and S.-i. Nakao, *Ind. Eng. Chem. Res.*, **36**(10), 4217 (1997).
48. V. Sebastián, I. Kumakiri, R. Bredesen and M. Menéndez, *J. Membr. Sci.*, **292**(1-2), 92 (2007).
49. J. Zou and W. S. W. Ho, *J. Membr. Sci.*, **286**(1-2), 310 (2006).
50. A. Wright, V. White, J. Hufton, E. v. Selow and P. Hinderink, *Energy Procedia*, **1**(1), 707 (2009).
51. P. Kolbitsch, T. Pröll, J. Bolhar-Nordenkamp and H. Hofbauer, *Energy Procedia*, **1**(1), 1465 (2009).
52. M. Rydén, A. Lyngfelt, T. Mattisson, D. Chen, A. Holmen and E. Bjørgum, *Int. J. Greenhouse Gas Control*, **2**(1), 21 (2008).
53. J. Ikonich, C. Myers, H. Pennline and D. Luebke, *J. Membr. Sci.*, **298**(1-2), 41 (2007).
54. *CO2 capturing*, IEA Greenhouse Gas R&D Programme (2007).
55. H. R. Kim, D. Wang, L. Zeng, S. Bayham, A. Tong, E. Chung, M. V. Kathe, S. Luo, O. McGiveron, A. Wang, Z. Sun, D. Chen and L.-S. Fan, *Fuel*, **108**, 370 (2013).
56. D. P. Connell, D. A. Lewandowski, S. Ramkumar, N. Phalak, R. M. Statnick and L.-S. Fan, *Fuel*, **105**, 383 (2013).
57. W. Wang, S. Ramkumar, D. Wong and L.-S. Fan, *Fuel*, **92**(1), 94 (2012).
58. W. Wang, S. Ramkumar and L.-S. Fan, *Fuel*, **104**, 561 (2013).
59. H. J. Richter and K. Knoche, *ACS Symposium series*, **235**, 71 (1983).
60. M. Ishida and H. Jin, *Energy*, **19**(4), 415 (1994).
61. *An assessment of carbon capture technology and research opportunities*, GCEP Energy Assessment Analysis, Spring (2005).
62. A. Lyngfelt, B. Kronberger, J. Adanez, J. X. Morin and P. Hurst, *The grace project: Development of oxygen carrier particles for chemical-looping combustion. Design and operation of a 10 kW chemical-looping combustor*, E. S. Rubin, et al., Elsevier Science Ltd., Oxford (2005).
63. S. Y. Chuang, J. S. Dennis, A. N. Hayhurst and S. A. Scott, *Combust. Flame*, **154**(1-2), 109 (2008).
64. A. Abad, J. Adánez, F. García-Labiano, L. F. de Diego and P. Gayán, *Combust. Flame*, **157**(3), 602 (2010).
65. A. Abad, T. Mattisson, A. Lyngfelt and M. Johansson, *Fuel*, **86**(7-8), 1021 (2007).
66. F. He, H. Wang and Y. Dai, *J. Nat. Gas Chem.*, **16**(2), 155 (2007).
67. A. Abad, T. Mattisson, A. Lyngfelt and M. Rydén, *Fuel*, **85**(9), 1174 (2006).
68. P. Gayán, L. F. de Diego, F. García-Labiano, J. Adánez, A. Abad and C. Dueso, *Fuel*, **87**(12), 2641 (2008).
69. M. Ishida, M. Yamamoto and T. Ohba, *Energy Convers. Manage.*, **43**(9-12), 1469 (2002).
70. L. Shen, M. Zheng, J. Xiao and R. Xiao, *Combust. Flame*, **154**(3), 489 (2008).
71. H. Leion, A. Lyngfelt, M. Johansson, E. Jerndal and T. Mattisson, *Chem. Eng. Res. Des.*, **86**(9), 1017 (2008).
72. H. E. Andrus, J. H. Chiu, P. R. Thibeault and A. Brautsch, *Alstom's calcium oxide chemical looping combustion coal power technology development*, 34<sup>th</sup> International Technical Conference on Clean Coal & Fuel Systems, Florida, USA (2009).
73. J. Yu, A. B. Corripio, D. P. Harrison and R. J. Copeland, *Adv. Environ. Res.*, **7**(2), 335 (2003).
74. B. Erlach, M. Schmidt and G. Tsatsaronis, *Energy*, **36**(6), 3804 (2011).
75. S. Ma'mum, H. F. Svendsen, K. A. Hoff and O. Juliussen, *Selection of new absorbents for carbon dioxide capture*, E. S. Rubin, et al., Elsevier Science Ltd., Oxford (2005).
76. A. Bello and R. O. Idem, *Ind. Eng. Chem. Res.*, **45**(8), 2569 (2005).
77. G. S. Goff and G. T. Rochelle, *Ind. Eng. Chem. Res.*, **45**(8), 2513 (2005).
78. A. O. Lawal and R. O. Idem, *Ind. Eng. Chem. Res.*, **45**(8), 2601 (2006).
79. T. Supap, R. Idem, P. Tontiwachwuthikul and C. Saiwan, *Ind. Eng. Chem. Res.*, **45**(8), 2437 (2005).
80. J. Xiao, C.-W. Li and M.-H. Li, *Chem. Eng. Sci.*, **55**(1), 161 (2000).
81. J.-Y. Park, S. J. Yoon and H. Lee, *Environ. Sci. Technol.*, **37**(8), 1670 (2003).
82. E. B. Rinker, S. S. Ashour and O. C. Sandall, *Ind. Eng. Chem. Res.*, **39**(11), 4346 (2000).
83. S. Ma, H. Song, M. Wang, J. Yang and B. Zang, *Chem. Eng. Res. Des.*, **91**(7), 1327 (2013).
84. J. D. Figueroa, T. Fout, S. Plasynski, H. Mcllvried and R. D. Srivastava, *Int. J. Greenhouse Gas Control*, **2**(1), 9 (2008).
85. P. D. Jared P. Ciferno and Thomas Tarka, *An economic scoping study for CO2 capture using aqueous ammonia*, US DOE/NETL, Pittsburgh, PA (2005).
86. Z. Niu, Y. Guo, Q. Zeng and W. Lin, *Fuel Process. Technol.*, **108**, 154 (2013).
87. K. Han, C. K. Ahn, M. S. Lee, C. H. Rhee, J. Y. Kim and H. D. Chun, *Int. J. Greenhouse Gas Control*, **14**, 270 (2013).
88. H. Thee, Y. A. Suryaputradinata, K. A. Mumford, K. H. Smith, G. d. Silva, S. E. Kentish and G. W. Stevens, *Chem. Eng. J.*, **210**, 271 (2012).
89. K. H. Smith, C. J. Anderson, W. Tao, K. Endo, K. A. Mumford, S. E. Kentish, A. Qader, B. Hooper and G. W. Stevens, *Int. J. Greenhouse Gas Control*, **10**, 64 (2012).
90. J. T. Cullinane and G. T. Rochelle, *Chem. Eng. Sci.*, **59**(17), 3619 (2004).
91. A. Kohandaraman, *Carbon dioxide capture by chemical absorption: A solvent comparison study*, PhD Thesis, MIT, USA (2010).
92. T. Greer, A. Bedelbayev, J. M. Igreja, J. F. Gomes and B. Lie, *Environ. Technol.*, **31**(1), 107 (2010).
93. N. A. Al-Baghli, S. A. Pruess, V. F. Yesavage and M. S. Selim, *Fluid Phase Equilibria*, **185**(1-2), 31 (2001).
94. F. A. Tobiesen, O. Juliussen and H. F. Svendsen, *Chem. Eng. Sci.*, **63**(10), 2641 (2008).
95. H. M. Kvamsdal, J. P. Jakobsen and K. A. Hoff, *Chem. Eng. Process. Process Intensif.*, **48**(1), 135 (2009).
96. S. A. Jayarathna, B. Lie and M. C. Melaaen, *Comput. Chem. Eng.*, **53**, 178 (2013).
97. S. A. Jayarathna, B. Lie and M. C. Melaaen, *Int. J. Greenhouse Gas Control*, **14**, 282 (2013).

98. N. Harun, T. Nittaya, P. L. Douglas, E. Croiset and L. A. Ricardez-Sandoval, *Int. J. Greenhouse Gas Control*, **10**, 295 (2012).
99. S. Posch and M. Haider, *Chem. Eng. Res. Des.*, **91**(6), 977 (2013).
100. J. Gaspar and A.-M. Cormos, *Int. J. Greenhouse Gas Control*, **8**, 45 (2012).
101. K. Prölb, H. Tummescheit, S. Velut and J. Åkesson, *Energy Procedia*, **4**, 2620 (2011).
102. J. Åkesson, C. D. Laird, G. Lavedan, K. Prölb, H. Tummescheit, S. Velut and Y. Zhu, *Chem. Eng. Tech.*, **35**(3), 445 (2012).
103. A. J. Sexton, *Amine oxidation in CO<sub>2</sub> capture processes*, PhD Thesis, The University of Texas at Austin (2008).
104. L. Kucka, I. Müller, E. Y. Kenig and A. Górak, *Chem. Eng. Sci.*, **58**(16), 3571 (2003).
105. E. Y. Kenig, R. Schneider and A. Górak, *Chem. Eng. Sci.*, **56**(2), 343 (2001).
106. R. Dugas, P. Alix, E. Lemaire, P. Broutin and G. Rochelle, *Energy Procedia*, **1**(1), 103 (2009).
107. A. Lawal, M. Wang, P. Stephenson and H. Yeung, *Fuel*, **88**(12), 2455 (2009).
108. A. Lawal, M. Wang, P. Stephenson, G. Koumpouras and H. Yeung, *Fuel*, **89**(10), 2791 (2010).
109. A. Lawal, M. Wang, P. Stephenson and O. Obi, *Fuel*, **101**, 115 (2012).
110. B. Hanley and H. Shethna, *Improved mass transfer correlations for random and structured packings*, AIChE Spring Meeting & 6<sup>th</sup> Global Congress on Process Safety (2010).
111. E. Y. Kenig, L. Kucka and A. Górak, *Chem. Ing. Tech.*, **74**(6), 745 (2002).
112. A. Arce, N. Mac Dowell, N. Shah and L. F. Vega, *Int. J. Greenhouse Gas Control*, **11**, 236 (2012).
113. N. Mac Dowell and N. Shah, *Int. J. Greenhouse Gas Control*, **13**, 44 (2013).
114. C. Biliyok, A. Lawal, M. Wang and F. Seibert, *Int. J. Greenhouse Gas Control*, **9**, 428 (2012).
115. G. D. Pirngruber, F. Guillou, A. Gomez and M. Clausse, *Int. J. Greenhouse Gas Control*, **14**, 74 (2013).
116. P. Mores, N. Scenna and S. Mussati, *Int. J. Greenhouse Gas Control*, **6**, 21 (2012).
117. G. Valenti, D. Bonalumi and E. Macchi, *Fuel*, **101**, 74 (2012).
118. S. Freguia and G. T. Rochelle, *AIChE J.*, **49**(7), 1676 (2003).
119. J. M. Plaza, D. V. Wagener and G. T. Rochelle, *Energy Procedia*, **1**(1), 1171 (2009).
120. I. Halim and R. Srinivasan, *A simulation-optimization framework for efficient CO<sub>2</sub> capture using amine absorption*, *Proceedings of 12<sup>th</sup> Conference on Process Integration, Modelling and Optimisation for Energy Saving and Pollution Reduction*, Rome, Italy: Chemical Engineering Transactions (2009).
121. P. Mores, N. Scenna and S. Mussati, *Chem. Eng. Res. Des.*, **89**(9), 1587 (2011).
122. A. B. Rao and E. S. Rubin, *Ind. Eng. Chem. Res.*, **45**(8), 2421 (2006).
123. E. S. Rubin, C. Chen and A. B. Rao, *Energy Pol.*, **35**(9), 4444 (2007).
124. J. Klemeš, I. Bulatov and T. Cockerill, *Comput. Chem. Eng.*, **31**(5-6), 445 (2007).
125. M. R. M. Abu-Zahra, L. H. J. Schneiders, J. P. M. Niederer, P. H. M. Feron and G. F. Versteeg, *Int. J. Greenhouse Gas Control*, **1**(1), 37 (2007).
126. P. Mores, N. Rodríguez, N. Scenna and S. Mussati, *Int. J. Greenhouse Gas Control*, **10**, 148 (2012).
127. M. Karimi, M. Hillestad and H. F. Svendsen, *Chem. Eng. Res. Des.*, **89**(8), 1229 (2011).
128. B. A. Oyenekan and G. T. Rochelle, *AIChE J.*, **53**(12), 3144 (2007).
129. M. S. Jassim and G. T. Rochelle, *Ind. Eng. Chem. Res.*, **45**(8), 2465 (2005).
130. L. A. Pellegrini, S. Moiola and S. Gamba, *Chem. Eng. Res. Des.*, **89**(9), 1676 (2011).
131. B. A. Oyenekan and G. T. Rochelle, *Ind. Eng. Chem. Res.*, **45**(8), 2457 (2005).
132. D. H. Van Wagener and G. T. Rochelle, *Chem. Eng. Res. Des.*, **89**(9), 1639 (2011).
133. J. Gáspár and A.-M. Cormos, *Comput. Chem. Eng.*, **35**(10), 2044 (2011).
134. A. Ghaemi, S. Shahhosseini and M. G. Maragheh, *Chem. Eng. J.*, **149**(1-3), 110 (2009).
135. R. Schneider, F. Sander and A. Górak, *Chem. Eng. Process. Process Intensif.*, **42**(12), 955 (2003).
136. S. A. Jayarathna, B. Lie and M. C. Melaaen, *Energy Procedia*, **4**, 1797 (2011).
137. H. Chalmers, M. Lucquiaud, J. Gibbins and M. Leach, *J. Environ. Eng.*, **135**(6), 449 (2009).
138. S. Ziaii, G. T. Rochelle and T. F. Edgar, *Ind. Eng. Chem. Res.*, **48**(13), 6105 (2009).
139. S. Ziaii, S. Cohen, G. T. Rochelle, T. F. Edgar and M. E. Webber, *Energy Procedia*, **1**(1), 4047 (2009).
140. Y.-J. Lin, T.-H. Pan, D. S.-H. Wong, S.-S. Jang, Y.-W. Chi and C.-H. Yeh, *Ind. Eng. Chem. Res.*, **50**(3), 1338 (2010).
141. M. Panahi, M. Karimi, S. Skogestad, M. Hillestad and H. F. Svendsen, *Self-optimizing and control structure design for a CO<sub>2</sub> capturing plant*, *Proceedings of the 2<sup>nd</sup> Annual Gas Processing Symposium*, Amsterdam, Elsevier (2010).
142. A. Behroozsarand and S. Shafiei, *J. Nat. Gas Sci. Eng.*, **2**(6), 284 (2010).
143. M. Panahi and S. Skogestad, *Chem. Eng. Process. Process Intensif.*, **50**(3), 247 (2011).
144. M. Panahi and S. Skogestad, *Chem. Eng. Process. Process Intensif.*, **52**, 112 (2012).
145. H. W. Pennline, D. R. Luecke, K. L. Jones, C. R. Myers, B. I. Morsi, Y. J. Heintz and J. B. Ilconich, *Fuel Process. Technol.*, **89**(9), 897 (2008).
146. D. R. L. Henry W. Pennline, Kenneth L. Jones, Badie I. Morsi, Yannick J. Heintz and Jeffery B. Ilconich, *Carbon dioxide capture and separation techniques for gasification-based power generation point sources*, 100<sup>th</sup> AWMA Annual Conference and Exhibition, Pittsburgh, PA (2007).
147. A. H. William Breckenridge, James O. Y. Ong and Curtis Sharp, *Use of SELEXOL process in coke gasification to ammonia project*, *Gas treating technical paper*, Laurance Reid Gas Conditioning Conference, The University of Oklahoma Norman, Oklahoma (2000).
148. D. R. S. Nick Korens and Donald J. Wilhelm, *Process screening analysis of alternative gas treating and sulfur removal for gasification*, U.S. DOE, NETL Pittsburgh (2002).
149. L. Sun and R. Smith, *J. Cleaner Prod.*, **39**, 321 (2013).
150. A. Padurean, C.-C. Cormos and P.-S. Agachi, *Int. J. Greenhouse*

- Gas Control*, **7**, 1 (2012).
151. Midwest Geological sequestration consortium (MGSC), National energy technology laboratory (2004).
  152. E. Freireich and R. N. Tennyson, *Increased natural gas recovery from physical solvent gas treating systems*, *Proceedings of the Laurance Reid Gas Conditioning Conference*, Norman (1977).
  153. J. Mak, D. Nielsen and D. Schulte, *An update of the Fluor solvent process*, *Proceedings of the Laurance Reid Gas Conditioning Conference*, Norman (2007).
  154. M. Kriebel, *Ullmann's Encyclopedia of Industrial chemistry, Gas Purification*, Weinheim, Germany (1989).
  155. N. Otter, *Carbon dioxide capture and storage, Report of DTI international technology service mission to the USA and Canada*, Advanced Power Generation Technology Forum (2001).
  156. C. A.-G. Collot, *Draft-Prospects for hydrogen from coal*, IEA Coal Research, The Clean Coal Centre, UK (2003).
  157. M. Gupta, I. Coyle, K. Thambimuthu and C. E. T. Centre, *CO<sub>2</sub> Capture Technologies and Opportunities in Canada: "Strawman Document for CO<sub>2</sub> Capture and Storage (CC & S) Technology Roadmap."*, CANMET Energy Technology Centre, Natural Resources Canada (2003).
  158. S. Rezvani, Y. Huang, D. McIlveen-Wright, N. Hewitt and J. D. Mondol, *Fuel*, **88**(12), 2463 (2009).
  159. M. Kanniche and C. Bouallou, *Appl. Therm. Eng.*, **27**(16), 2693 (2007).
  160. C. Descamps, C. Bouallou and M. Kanniche, *Energy*, **33**(6), 874 (2008).
  161. C.-C. Cormos, *Int. J. Hydrog. Energy*, **35**(14), 7485 (2010).
  162. C. Chen and E. S. Rubin, *Energy Pol.*, **37**(3), 915 (2009).
  163. C. Chen, *A technical and economic assessment of CO<sub>2</sub> capture technology for IGCC power plants*, PhD Thesis, Carnegie Mellon University, Pttsburgh (2005).
  164. W. Guo, F. Feng, G. Song, J. Xiao and L. Shen, *J. Nat. Gas Chem.*, **21**(6), 633 (2012).
  165. D. P. Harrison, *The role of solids in CO<sub>2</sub> capture: A mini review*, Department of Chemical Engineering, Louisiana State University, Baton Rouge, Louisiana 70803.
  166. B. G. Miller, *10 - CO<sub>2</sub> Capture and Storage*, Butterworth-Heinemann, Boston (2011).
  167. G. Li, P. Xiao, P. Webley, J. Zhang, R. Singh and M. Marshall, *Adsorption*, **14**(2-3), 415 (2008).
  168. J. Zhang and P. A. Webley, *Environ. Sci. Technol.*, **42**(2), 563 (2008).
  169. J. Zhang, P. Xiao, G. Li and P. A. Webley, *Energy Procedia*, **1**(1), 1115 (2009).
  170. K. T. Chue, J. N. Kim, Y. J. Yoo, S. H. Cho and R. T. Yang, *Ind. Eng. Chem. Res.*, **34**(2), 591 (1995).
  171. J.-H. Park, H.-T. Beum, J.-N. Kim and S.-H. Cho, *Ind. Eng. Chem. Res.*, **41**(16), 4122 (2002).
  172. T. C. Drage, A. Arenillas, K. M. Smith and C. E. Snape, *Micropor. Mesopor. Mater.*, **116**(1-3), 504 (2008).
  173. J. Bonjour, J.-B. Chalfen and F. Meunier, *Ind. Eng. Chem. Res.*, **41**(23), 5802 (2002).
  174. M. Clausse, J. Bonjour and F. Meunier, *Adsorption*, **9**(1), 77 (2003).
  175. A. D. E. James A. Ritter, Steven P. Reynolds, Hai Du and Amal Mehrotra, *New adsorption cycles for carbon dioxide capture and concentration*, University of South Carolina, Department of Chemical Engineering, Columbia, SC 29208 (2009).
  176. S. Irene, *CO<sub>2</sub> reduction-prospects for coal*, IEA-Coal, CCC/26 (1999).
  177. M. Ishibashi, H. Ota, N. Akutsu, S. Umeda, M. Tajika, J. Izumi, A. Yasutake, T. Kabata and Y. Kageyama, *Energy Convers. Manage.*, **37**(6-8), 929 (1996).
  178. C. Stewart and M.-A. Hessami, *Energy Convers. Manage.*, **46**(3), 403 (2005).
  179. C. Shen, C. A. Grande, P. Li, J. Yu and A. E. Rodrigues, *Chem. Eng. J.*, **160**(2), 398 (2010).
  180. M. G. Plaza, S. Garcia, F. Rubiera, J. J. Pis and C. Pevida, *Chem. Eng. J.*, **163**(1-2), 41 (2010).
  181. S. Garcia, M. V. Gil, C. F. Martín, J. J. Pis, F. Rubiera and C. Pevida, *Chem. Eng. J.*, **171**(2), 549 (2011).
  182. R. V. Siriwardane, M.-S. Shen, E. P. Fisher and J. A. Poston, *Energy Fuel*, **15**(2), 279 (2001).
  183. Linde AG, Engineering Division, *Rectisol Wash* (2007). Available from: [http://www.linde-engineering.com/en/process\\_plants/hydrogen\\_and\\_synthesis\\_gas\\_plants/gas\\_processing\\_plants/rectisol\\_wash/index.html](http://www.linde-engineering.com/en/process_plants/hydrogen_and_synthesis_gas_plants/gas_processing_plants/rectisol_wash/index.html).
  184. B. P. Spigarelli and S. K. Kawatra, *Journal of CO<sub>2</sub> Utilization*, **1**, 69 (2013).
  185. B. Arstad, H. Fjellvåg, K. O. Kongshaug, O. Swang and R. Blom, *Adsorption*, **14**(6), 755 (2008).
  186. A. R. Millward and O. M. Yaghi, *J. Am. Chem. Soc.*, **127**(51), 17998 (2005).
  187. C. Zhao, X. Chen, E. J. Anthony, X. Jiang, L. Duan, Y. Wu, W. Dong and C. Zhao, *Prog. Energy Combust. Sci.*, DOI:10.1016/j.pecs.2013.05.001 (2013).
  188. Y. Lara, P. Lisbona, A. Martínez and L. M. Romeo, *Energy Procedia*, **1**(1), 1359 (2009).
  189. S. Lee and J. Kim, *Catal. Surv. Asia*, **11**(4), 171 (2007).
  190. S. C. Lee, B. Y. Choi, T. J. Lee, C. K. Ryu, Y. S. Ahn and J. C. Kim, *Catal. Today*, **111**(3-4), 385 (2006).
  191. S. C. Lee, Y. M. Kwon, C. Y. Ryu, H. J. Chae, D. Ragupathy, S. Y. Jung, J. B. Lee, C. K. Ryu and J. C. Kim, *Fuel*, **90**(4), 1465 (2011).
  192. K. Kim, S. Yang, J. B. Lee, T. H. Eom, C. K. Ryu, S.-H. Jo, Y. C. Park and C.-K. Yi, *Int. J. Greenhouse Gas Control*, **9**, 347 (2012).
  193. A. Iwan, H. Stephenson, W. C. Ketchie and A. A. Lapkin, *Chem. Eng. J.*, **146**(2), 249 (2009).
  194. E. Ochoa-Fernández, M. Rønning, T. Grande and D. Chen, *Chem. Mater.*, **18**(6), 1383 (2006).
  195. T. Ohashi and K. Nakagawa, *MRS Online Proceedings Library*, **547**, 249 (1998).
  196. M. Kato and K. Nakagawa, *J. Ceram. Soc. Jpn.*, **109**(1275), 911 (2001).
  197. M. Kato, Nakagawa, K., Ohashi, T., Yoshikawa and S., Essaki, K. U. Patent, US006387845B1 (2002b).
  198. K. Essaki, K. Nakagawa, M. Kato and H. Uemoto, *J. Chem. Eng. Jpn.*, **37**(6), 772 (2004).
  199. N. K. Essaki Kenji, Kato Masahiro and Uemoto Hideo, *J. Chem. Eng. Jpn.*, **37**(6), 772 (2004).
  200. K. Essaki, M. Kato and H. Uemoto, *J. Mater. Sci.*, **40**(18), 5017 (2005).
  201. D. Cruz, S. Bulbulian, E. Lima and H. Pfeiffer, *J. Solid State Chem.*, **179**(3), 909 (2006).
  202. M. K. a. K. N. Kenji Essaki, *J. Ceram. Soc. Jpn.*, **114**(9), 739

- (2006).
203. T. Yamaguchi, T. Niitsuma, B. N. Nair and K. Nakagawa, *J. Membr. Sci.*, **294**(1-2), 16 (2007).
204. K. Essaki, T. Muramatsu and M. Kato, *Int. J. Hydrog. Energy*, **33**(22), 6612 (2008).
205. M. Olivares-Marín, T. C. Drage and M. M. Maroto-Valer, *Int. J. Greenhouse Gas Control*, **4**(4), 623 (2010).
206. K. Essaki, T. Muramatsu and M. Kato, *Int. J. Hydrog. Energy*, **33**(17), 4555 (2008).
207. M. Kato, S. Yoshikawa and K. Nakagawa, *J. Mater. Sci. Lett.*, **21**(6), 485 (2002).
208. B. N. Nair, R. P. Burwood, V. J. Goh, K. Nakagawa and T. Yamaguchi, *Prog. Mater. Sci.*, **54**(5), 511 (2009).
209. R. Xiong, *Novel inorganic sorbent for high temperature carbon dioxide separation*, Master of Science, University of Cincinnati (2003).
210. K. Nakagawa and T. Ohashi, *J. Electrochem. Soc.*, **145**(4), 1344 (1998).
211. M. J. Venegas, E. Fregoso-Israel, R. Escamilla and H. Pfeiffer, *Ind. Eng. Chem. Res.*, **46**(8), 2407 (2007).
212. M. Seggiani, M. Puccini and S. Vitolo, *Int. J. Greenhouse Gas Control*, **5**(4), 741 (2011).
213. K. Terasaka, Y. Suyama, K. Nakagawa, M. Kato and K. Essaki, *Chem. Eng. Technol.*, **29**(9), 1118 (2006).
214. R. B. Khomane, B. K. Sharma, S. Saha and B. D. Kulkarni, *Chem. Eng. Sci.*, **61**(10), 3415 (2006).
215. Y. Liang, D. P. Harrison, R. P. Gupta, D. A. Green and W. J. McMichael, *Energy Fuel*, **18**(2), 569 (2004).
216. T. N. David A. Green, Brian S. Turk, Paul Box, Weijiong Li and Raghur P. Gupta, *Carbon dioxide capture from flue gas using dry regenerable sorbents*, Research Triangle Institute (2005).
217. G. G. Santillán-Reyes and H. Pfeiffer, *Int. J. Greenhouse Gas Control*, **5**(6), 1624 (2011).
218. R. R. Kondakindi, G. McCumber, S. Aleksic, W. Whittenberger and M. A. Abraham, *Int. J. Greenhouse Gas Control*, **15**, 65 (2013).
219. S. C. Lee, H. J. Chae, S. J. Lee, Y. H. Park, C. K. Ryu, C. K. Yi and J. C. Kim, *J. Mol. Catal. B: Enzym.*, **56**(2-3), 179 (2009).
220. S. Lee, Y. Kwon, Y. Park, W. Lee, J. Park, C. Ryu, C. Yi and J. Kim, *Top. Catal.*, **53**(7-10), 641 (2010).
221. S. C. Lee, H. J. Chae, Y. M. Kwon, W. S. Lee, H. S. Nam, S. Y. Jung, J. B. Lee, C. K. Ryu and J. C. Kim, *J. Nanoelectron. Optoelectron.*, **5**(2), 212 (2010).
222. S. Lee, H. Chae, B. Choi, S. Jung, C. Ryu, J. Park, J.-I. Baek, C. Ryu and J. Kim, *Korean J. Chem. Eng.*, **28**(2), 480 (2011).
223. J. B. Lee, T. H. Eom, B. S. Oh, J.-I. Baek, J. Ryu, W. S. Jeon, Y. H. Wi and C. K. Ryu, *Energy Procedia*, **4**, 1494 (2011).
224. S. C. Lee, Y. M. Kwon, H. J. Chae, S. Y. Jung, J. B. Lee, C. K. Ryu, C. K. Yi and J. C. Kim, *Fuel*, **104**, 882 (2013).
225. C.-K. Yi, S.-H. Jo, Y. Seo, J.-B. Lee and C.-K. Ryu, *Int. J. Greenhouse Gas Control*, **1**(1), 31 (2007).
226. Y. C. Park, S.-H. Jo, C. K. Ryu and C.-K. Yi, *Energy Procedia*, **1**(1), 1235 (2009).
227. Y. C. Park, S.-H. Jo, C. K. Ryu and C.-K. Yi, *Energy Procedia*, **4**, 1508 (2011).
228. Y. Park, S.-H. Jo, K.-W. Park, Y. Park and C.-K. Yi, *Korean J. Chem. Eng.*, **26**(3), 874 (2009).
229. Y. Seo, S. Jo, C. Ryu and C. Yi, *J. Environ. Eng.*, **135**(6), 473 (2009).
230. O.-a. Jaiboon, B. Chalermisinsuwan, L. Mekasut and P. Piumsomboon, *Chem. Eng. J.*, **219**, 262 (2013).
231. R. Veneman, Z. S. Li, J. A. Hogendoorn, S. R. A. Kersten and D. W. F. Brilman, *Chem. Eng. J.*, **207-208**, 18 (2012).
232. S. Sjoström and H. Krutka, *Fuel*, **89**(6), 1298 (2010).
233. S. Kwon, M. Fan, H. F. M. DaCosta, A. G. Russell, K. A. Berchtold and M. K. Dubey, *Chapter 10 - CO<sub>2</sub> Sorption*, William Andrew Publishing: Boston (2011).
234. F. Rezaei, A. Mosca, P. Webley, J. Hedlund and P. Xiao, *Ind. Eng. Chem. Res.*, **49**(10), 4832 (2010).
235. R. P. Lively, D. P. Leta, B. A. DeRites, R. R. Chance and W. J. Koros, *Chem. Eng. J.*, **171**(3), 801 (2011).
236. Y. Labreche, R. P. Lively, F. Rezaei, G. Chen, C. W. Jones and W. J. Koros, *Chem. Eng. J.*, **221**, 166 (2013).
237. F. Rezaei and P. Webley, *Sep. Purif. Technol.*, **70**(3), 243 (2010).
238. J. H. Drese, S. Choi, R. P. Lively, W. J. Koros, D. J. Fauth, M. L. Gray and C. W. Jones, *Adv. Funct. Mater.*, **19**(23), 3821 (2009).
239. R. P. Lively, R. R. Chance, B. T. Kelley, H. W. Deckman, J. H. Drese, C. W. Jones and W. J. Koros, *Ind. Eng. Chem. Res.*, **48**(15), 7314 (2009).
240. Z. Xiang, D. Cao, J. Lan, W. Wang and D. P. Broom, *Energy Environ. Sci.*, **3**(10), 1469 (2010).
241. H. Gao, S. Pishney and M. J. Janik, *Surf. Sci.*, **609**, 140 (2013).
242. Y. Jing, L. Wei, Y. Wang and Y. Yu, *Chem. Eng. J.*, **220**, 264 (2013).
243. R. S. Pillai, S. A. Peter and R. V. Jasra, *Micropor. Mesopor. Mater.*, **162**, 143 (2012).
244. B. J. Maring and P. A. Webley, *Int. J. Greenhouse Gas Control*, **15**, 16 (2013).
245. J. Ylälä, J. Ritvanen, B. Arias, T. Tynjälä and T. Hyppänen, *Int. J. Greenhouse Gas Control*, **9**, 130 (2012).
246. E. Abbasi, A. Hassanzadeh and J. Abbasian, *Fuel*, **105**, 128 (2013).
247. K. Nakagawa and T. Ohashi, *J. Electrochem. Soc.*, **145**(4), 1344 (1998).
248. J. Schell, N. Casas and M. Mazzotti, *Energy Procedia*, **1**(1), 655 (2009).
249. J. R. Moate and M. D. LeVan, *Appl. Therm. Eng.*, **30**(6-7), 658 (2010).
250. Y. S. Yu, W. Q. Liu, H. An, F. S. Yang, G. X. Wang, B. Feng, Z. X. Zhang and V. Rudolph, *Int. J. Greenhouse Gas Control*, **10**, 510 (2012).
251. N. Casas, J. Schell, L. Joss and M. Mazzotti, *Sep. Purif. Technol.*, **104**, 183 (2013).
252. I. Martínez, G. Grasa, R. Murillo, B. Arias and J. C. Abanades, *Chem. Eng. J.*, **215-216**, 174 (2013).
253. K. A. Berchtold, *Novel polymeric-metallic composite membranes for CO<sub>2</sub> separation at elevated temperatures*, American Filtration and Separation Society Fall Topical Conference, Pittsburgh, PA (2006).
254. R. Bounaceur, N. Lape, D. Roizard, C. Vallieres and E. Favre, *Energy*, **31**(14), 2556 (2006).
255. J. C. M. Pires, F. G. Martins, M. C. M. Alvim-Ferraz and M. Simões, *Chem. Eng. Res. Des.*, **89**(9), 1446 (2011).
256. C. A. Scholes, S. E. Kentish and G. W. Stevens, *Energy Procedia*, **1**(1), 311 (2009).
257. C. A. Scholes, G. W. Stevens and S. E. Kentish, *J. Membr. Sci.*,

- 350(1-2), 189 (2010).
258. G. Xomeritakis, C. Y. Tsai, Y. B. Jiang and C. J. Brinker, *J. Membr. Sci.*, **341**(1-2), 30 (2009).
259. T. C. Merkel, H. Lin, X. Wei and R. Baker, *J. Membr. Sci.*, **359**(1-2), 126 (2010).
260. D. Shekhawat, R. D. Luebke and W. H. Pennline, *A review of carbon dioxide selective membranes—A topical report*, National Energy Technology Laboratory, United States Department of Energy (2003).
261. P. H. M. Feron, *Carbon dioxide capture: The characterisation of gas separation/removal membrane systems applied to the treatment of flue gases arising from power plant generation using fossil fuel*, IEA/92/08, IEA Greenhouse Gas R&D programme, Cheltenham, UK (1992).
262. O. Falk-Pedersen and H. Dannström, *Energy Convers. Manage.*, **38**, **Supplement**, S81 (1997).
263. F. Gallucci, E. Fernandez, P. Corengia and M. van Sint Annaland, *Chem. Eng. Sci.*, **92**, 40 (2013).
264. S. Ban and C. Huang, *J. Membr. Sci.*, **417-418**, 113 (2012).
265. M. T. Ho, G. W. Allinson and D. E. Wiley, *Ind. Eng. Chem. Res.*, **47**(5), 1562 (2008).
266. N. S. Siefert and S. Litster, *Appl. Energy*, **107**, 315 (2013).
267. K. Ramasubramanian, H. Verweij and W. S. Winston Ho, *J. Membr. Sci.*, **421-422**, 299 (2012).
268. R. Koc, N. K. Kazantzis, W. J. Nuttall and Y. H. Ma, *J. Loss Prev. Process Ind.*, **26**(3), 468 (2013).
269. J. Franz, S. Schiebahn, L. Zhao, E. Riensche, V. Scherer and D. Stolten, *Int. J. Greenhouse Gas Control*, **13**, 180 (2013).
270. A. Hussain and M.-B. Hägg, *J. Membr. Sci.*, **359**(1-2), 140 (2010).
271. B. Belaissaoui, D. Willson and E. Favre, *Chem. Eng. J.*, **211-212**, 122 (2012).
272. L. Zhao, R. Menzer, E. Riensche, L. Blum and D. Stolten, *Energy Procedia*, **1**(1), 269 (2009).
273. E. Favre, *J. Membr. Sci.*, **294**(1-2), 50 (2007).
274. K. Okabe, H. Mano and Y. Fujioka, *Int. J. Greenhouse Gas Control*, **2**(4), 485 (2008).
275. B. T. Low, L. Zhao, T. C. Merkel, M. Weber and D. Stolten, *J. Membr. Sci.*, **431**, 139 (2013).
276. D. Boccardo, M. C. Ferrari and S. Brandani, *Procedia Eng.*, **44**, 1278 (2012).
277. E. S. Rubin, *Elem.*, **4**(5), 311 (2008).
278. R. W. Baker, *Recent developments and future directions in membrane modules*, 12<sup>th</sup> Aachener membrane kolloquim, Aachen, Germany (2008).
279. S. Zhou, X. Chen, T. Nguyen, A. K. Voice and G. T. Rochelle,

*ChemSusChem*, **3**(8), 913 (2010).

280. G. T. R. Hongyi Dang, *CO<sub>2</sub> absorption rate and solubility in MEA/PZ/ water*, Prepared for presentation at the First National Conference on Carbon Sequestration, Washington, May 14-17 (2001).
281. P. R. Kevin, T. Y. James and W. P. Henry, *Int. J. Environ. Technol. Manage.*, **4**(1/2), 89 (2004).
282. A. Aboudheir, P. Tontiwachwuthikul and R. Idem, *Ind. Eng. Chem. Res.*, **45**(8), 2553 (2005).
283. Y. Liu, L. Zhang and S. Watanasiri, *Ind. Eng. Chem. Res.*, **38**(5), 2080 (1999).
284. F. M. Khan, V. Krishnamoorthi and T. Mahmud, *Chem. Eng. Res. Des.*, **89**(9), 1600 (2011).
285. A. Bedelbayev, *Model based control of absorption column for CO<sub>2</sub> capturing*, M.Sc. Thesis, 2008, Telemark University College, Porsgrunn, Norway.
286. T. Greer, *Modeling and simulation of post combustion CO<sub>2</sub> capturing*, M.Sc. Thesis, Telemark University College, Porsgrunn, Norway (2008).



**Jay H. Lee** obtained his B.S. degree in Chemical Engineering from the University of Washington, Seattle, in 1986, and his Ph.D. degree in Chemical Engineering from California Institute of Technology, Pasadena, in 1991. From 1991 to 1998, he was with the Department of Chemical Engineering at Auburn University, AL, as an Assistant Professor and an Associate Professor. From 1998-2000, he was with School of Chemical Engineering at Purdue University, West Lafayette and then with the School of Chemical Engineering at Georgia Institute of Technology, Atlanta. Starting this fall, he is the Head of the Chemical and Biomolecular Engineering Department at KAIST, Korea. He has held visiting appointments at E. I. Du Pont de Numours, Wilmington, in 1994 and at Seoul National University, Seoul, Korea, in 1997. He was a recipient of the National Science Foundation's Young Investigator Award in 1993 and was elected as an IEEE Fellow, an IFAC Fellow, and a full member of the Korean Academy of Science and Technology in 2011. He is also the recipient of the 2013 *Computing in Chemical Engineering Award* given by the AIChE's CAST Division. He published over 130 manuscripts in SCI journals with more than 3200 ISI citations. His research interests are in the areas of system identification, state estimation, robust control, model predictive control and approximate dynamic programming.