

## Dehydrogenation of isobutane over Sn/Pt/Na-ZSM-5 catalysts: The effect of SiO<sub>2</sub>/Al<sub>2</sub>O<sub>3</sub> ratio, amount and distribution of Pt nanoparticles on the catalytic behavior

Sedigheh Vaezifar<sup>\*\*\*\*\*</sup>, Hossein Faghihian<sup>\*\*\*</sup>, and Mahdi Kamali<sup>\*\*\*\*\*†</sup>

\*Biomaterials Group, Department of Materials Engineering, Isfahan University of Technology, Isfahan, I. R. Iran  
\*\*Chemical Processes Research Department, Engineering Research Center, University of Isfahan, Isfahan, I. R. Iran  
\*\*\*Department of Chemistry, Islamic Azad University, Shahreza Branch, Isfahan, I. R. Iran  
\*\*\*\*Faculty of Advanced Sciences & Technologies, University of Isfahan, Isfahan 81746-73441, I. R. Iran  
\*\*\*\*\*Fadakh Chemical Company, Isfahan Science & Technology Town (ISTT), Isfahan, I. R. Iran

(Received 3 April 2010 • accepted 30 June 2010)

**Abstract**—Sn/Pt/Na-ZSM-5 was used as catalyst for the dehydrogenation of isobutane, and the effect of SiO<sub>2</sub>/Al<sub>2</sub>O<sub>3</sub> ratio and the dispersion of Pt nanoparticles on the conversion and product selectivity were studied under atmospheric pressure at 848 K. The catalysts were characterized by various techniques such as H<sub>2</sub> chemisorption, TEM, SEM, EDX, XRD, FT-IR, TG/DTG, elemental analysis by XRF and ICP techniques. Higher dispersion of Pt nanoparticles in the catalyst with SiO<sub>2</sub>/Al<sub>2</sub>O<sub>3</sub> ratio of 40 resulted in higher selectivity for isobutene.

Key words: Na-ZSM-5, SiO<sub>2</sub>/Al<sub>2</sub>O<sub>3</sub> Ratio, Bimetallic Catalysts, Pt/Sn Nanoparticles, Dehydrogenation of Isobutane

### INTRODUCTION

Catalytic dehydrogenation of isobutane is important because of growing demand for isobutene as a precursor for the production of methyl tert-butylether (MTBE). MTBE is added to gasoline to improve the octane number, yielding cleaner burning fuel [1-5]. The industrial catalytic processes of isobutane dehydrogenation fall into two categories, those based on platinum as the active phase [6,7] and those based on chromia as the active phase [8]. Platinum-tin-alumina-supported catalysts have been widely used in many refinery processes including paraffin dehydrogenation [9]. Multicomponent catalysts based upon the Sn/Pt combination have found widespread industrial usage, and recent patents involving the Sn/Pt system include catalysts for naphtha reforming [10,11], reduction of nitrogen oxides in flue gases [12], and the dehydrogenation of light alkanes [13]. The deactivation of Pt-based catalysts used in reforming and dehydrogenation reactions is generally a fast process. It is known that the addition of elements like Re [14], Sn [15] and In [16] increases the lifespan of the catalysts. Supported bimetallic platinum-tin catalysts are now widely used to dehydrogenate isobutane into isobutene [17].

The influence of incipient operating conditions, Si/Al ratio of zeolite support and effect of zinc doping on Pt-Sn/ZSM-5 catalyst performance, was investigated. At Si/Al ratio 300, the selectivity of propene and total olefins became stable at 73% and 90%, respectively. The doping of Zn on Pt-Sn/ZSM-5 improved only propene selectivity [18]. The aim of the preparation of catalytic materials that can be employed on an industrial scale is to obtain a product with high activity, selectivity and stability. Therefore, the active phase (metal) must be in a sufficiently high dispersed form, which results

in a large specific surface area and consequently in a maximum specific activity. The active metal component is usually deposited on the surface of a support which is a highly porous and thermostable material with a high surface area and suitable mechanical strength. This support is able not only to disperse the metal but also to increase its thermal stability and hence the catalyst life. The common preparation methods of dispersed metal catalysts require a combination of different unit operations such as the introduction of the metal precursor on the support by impregnation, drying and calcinations, and reduction. Impregnation method requires that the support is contacted with a certain amount of solution of the metal precursor, usually a salt, which is then aged, usually for a short time, dried and calcined [19].

In one study, PtSn/ZSM-5 catalyst with different amounts of Sn was prepared for propane dehydrogenation. It was found that the addition of Sn not only had “geometric effect,” thus decreasing the size of the surface Pt ensembles, but also changed the interfacial character between metal and support. The presence of Sn could facilitate transfer of carbon deposits from the active sites to the carrier, which consequently improved the catalytic stability. Suitable concentration of Sn on PtSn/ZSM-5 catalyst was preferable for the reaction. With continuous addition of Sn, more amounts of Sn<sup>0</sup> species were formed, which may inhibit the reaction [20].

Small Pt clusters within Na-[Fe]ZSM5-protected channels catalyze C<sub>3</sub>H<sub>8</sub> and C<sub>2</sub>H<sub>6</sub> dehydrogenation with unprecedented turnover rates and catalyst stability [21].

Pt/Sn/Na-ZSM-5 catalysts with different amounts of Na were prepared by the sequential impregnation method on HZSM-5 zeolites, and their catalytic activities and stabilities in propane dehydrogenation were investigated. The results indicated that the addition of Na had an obvious impact on the catalytic performance of the PtSn/ZSM-5 catalyst. Suitable concentration of Na prevented the catalyst from coking and improved the catalytic stability by reduc-

<sup>†</sup>To whom correspondence should be addressed.  
E-mail: m.kamali@chem.ui.ac.ir, kamaliu@yahoo.com

ing the Brønsted acid sites and moderate/strong Lewis acid sites. It also increased the fraction of bare metallic Pt on the surface of the catalyst and therefore enhanced the catalytic activity. It was found that the propene selectivity and yield could reach the maximum when the Na content was 1.0%. After 30 h, the propane conversion was still high (36.4%). However, the continuous addition of Na increased the weak Lewis acid sites and promoted the reduction of Sn species to Sn<sup>0</sup> [22].

## EXPERIMENTAL SECTION

### 1. Synthesis of Na-ZSM-5 Zeolite

For synthesis of Na-ZSM-5, hydrated aluminum sulfate (Merck) and sodium silicate solution (Merck) were the sources of aluminum and silicon, respectively. The tetrapropylammonium bromide (Merck) was used as the structure-directing template [23].

#### 1-1. Synthesis of Na-ZSM-5 with SiO<sub>2</sub>/Al<sub>2</sub>O<sub>3</sub> Ratio of 40

2.50 g (0.043 mol) of sodium chloride and 1.18 g (0.00177 mol) of hydrated aluminum sulfate, Al<sub>2</sub>(SO<sub>4</sub>)<sub>3</sub>·18H<sub>2</sub>O, were dissolved in 10.7 ml (0.594 mol) of distilled water. 2.001 g (0.0075 mol) of tetrapropylammonium bromide, 7.7 ml (0.43 mol) of distilled water and 1.35 g (0.013 mol) of sulfuric acid were added with vigorous stirring. 15.02 g (0.071 mol SiO<sub>2</sub>) of sodium silicate solution was subsequently added and the mixture was stirred for 30 min. Then, 0.51 g (0.012 mol) sodium hydroxide was added to the gel and the mixture was stirred for 60 min. The mixture was transferred into an autoclave. The autoclave was kept in an oven at 110 °C for about 2 hours. Then the temperature was increased to 230 °C and kept at that level for another 5 hours. The solid phase obtained was filtered out, washed with distilled water several times, dried at 110 °C for 12 hours and subsequently calcined at 550 °C for 6 hours [23].

The molar ratios used for the synthesis of Na-ZSM-5 with SiO<sub>2</sub>/Al<sub>2</sub>O<sub>3</sub> ratio of 40 were as:

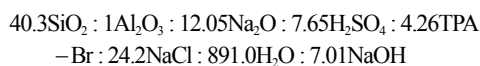

#### 1-2. Synthesis of Na-ZSM-5 with SiO<sub>2</sub>/Al<sub>2</sub>O<sub>3</sub> Ratio of 60

4.50 g (0.077 mol) of sodium chloride and 1.42 g (0.0024 mol) of hydrated aluminum sulfate were dissolved in 18.62 ml (1.03 mol) of distilled water. Then 3.41 g (0.0128 mol) of tetrapropylammonium bromide, 13.03 ml (0.724 mol) of distilled water and 1.71 g (0.017 mol) of sulfuric acid were added. The solution was mixed. 27.0 g (0.128 mol SiO<sub>2</sub>) of sodium silicate solution was added and the mixture was stirred vigorously for about 1 hour. The next step was performed as described in the previous section.

The molar ratios used for the synthesis of Na-ZSM-5 with SiO<sub>2</sub>/Al<sub>2</sub>O<sub>3</sub> ratio of 60 were as:

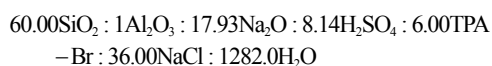

#### 1-3. Synthesis of Na-ZSM-5 with SiO<sub>2</sub>/Al<sub>2</sub>O<sub>3</sub> Ratio of 80

2.50 g (0.077 mol) of sodium chloride and 0.59 g (0.00089 mol) of hydrated aluminum sulfate were dissolved in 10.12 ml (0.562 mol) of distilled water. Then 1.89 g (0.0071 mol) of tetrapropylammonium bromide, 7.12 ml (0.396 mol) of distilled water and 1.088 g (0.01088 mol) of sulfuric acid were added. The solution was mixed. 15.0 g (0.123 mol SiO<sub>2</sub>) of sodium silicate solution was added and

the mixture was stirred vigorously for about 1 hour. The next step was performed as described in the previous section.

The molar ratios used for the synthesis of Na-ZSM-5 with SiO<sub>2</sub>/Al<sub>2</sub>O<sub>3</sub> ratio of 40 were as:

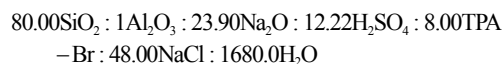

## 2. Preparation of Catalysts

The catalysts were prepared by sequential impregnation. Before the impregnation step, the supports were dehydrated at 383 K for 6 h in an oven [19].

The supports were Na-ZSM-5 in three different ratios of SiO<sub>2</sub>/Al<sub>2</sub>O<sub>3</sub>=40, 60 and 80. A prescribed amount of chloroplatinic acid (H<sub>2</sub>PtCl<sub>6</sub>·6H<sub>2</sub>O) was prepared to yield 0.50 wt% of platinum/support samples. Ethanol solution containing a prescribed amount of of Bu<sub>3</sub>Sn(Cl) was also prepared to yield 0.6 wt% of tin/platinum/support samples. Two different tin precursors of Bu<sub>3</sub>Sn(Cl) and SnCl<sub>2</sub>·2H<sub>2</sub>O were used to investigate the Pt dispersion. To study the effect of Pt amount, two catalysts were prepared with 0.50 and 0.35 wt% of platinum.

After impregnation, the impregnated material under went a drying treatment at 383 K for 17 h to eliminate the solvent used in the previous impregnation step. The impregnated and dried carrier was then calcined at 823 K for 2 h. During the calcination procedure, formation of an oxide and removal of gaseous products (usually water, CO<sub>2</sub>) occurs due to decomposition of the metal precursor. In this technique, a homogeneous dispersion of metal on support is achieved especially when dealing with a low metal concentration.

The obtained powders were converted to pellets under 10 bar pressure. Each pellet had a 50 mg weight, 2 mm thickness, and 5 mm diameter. The catalysts were characterized by H<sub>2</sub> chemisorption, transmission electron microscopy (TEM), scanning electron microscopy (SEM), energy dispersive X-ray analysis (EDX), X-ray powder diffraction (XRD), infrared spectroscopy (FT-IR), and thermogravimetric and differential thermal analysis (TG/DTG) techniques. Elemental analysis of the catalysts was also carried out by X-ray fluorescence analysis (XRF) and wet chemical analysis using inductively coupled plasma (ICP) techniques. H<sub>2</sub> uptake was measured in a static system operating at room temperature. Before the measurements the samples were reduced in H<sub>2</sub> at 823 K for 1 hour, and then cooled at room temperature. Chemisorption measurements were performed with a Micromeritics ASAP 2000. The particle size of the metal loaded on catalysts was estimated by TEM. The catalysts, stored under air, were suspended in ethanol and ultrasonically dispersed. Drops of the dispersions were applied on a copper grid-supported carbon film. A Philips CM12 TEM, operated at 120 kV, was used to investigate the samples. SEM and energy dispersive X-ray (EDX) analyses were performed with a Philips XL30. XRD patterns of the samples were recorded on a Bruker D8 ADVANCE using CuK<sub>α</sub> radiation. FT-IR was performed using the Nicolet Impact 400D instrument.

TG/DTG of the samples was recorded with a Mettler thermobalance TG50 instrument. Elemental analysis by XRF was performed with S4 PIONEER (BRUKER). An INTEGRA XL2; GBC, Dan-denong, instrument was used for ICP analysis.

Isobutane dehydrogenation was performed in a reactor working under atmospheric pressure at 848 K with an isobutane/hydrogen

ratio of 2/1 and flow rate dimension was (ml/min). After hydrogen treatment at 823 K, tin and platinum are in reduced form so that the tin atoms are located on the surface of the metallic particles [24].

Reactants and products were analyzed by PRICHROM 2100 gas chromatograph equipped with an automatic gas-sample valve. Products were separated in a packed column (SS 316, 6 m, 1/8 inch, 28% DC200 on chromosorb PAW 60/80, ENRO 3015) coupled to a flame ionization detector.

Total isobutane conversion is defined as the percentage of isobutane which is converted into all products. The selectivity of isobutene is defined as the percentage of the total amount of consumed isobutane which is converted into isobutene. These calculations were carried out by the following equations [25]:

$$\text{Conv} = \frac{[(F_{in} \times iC_{4in} \%) - (F_{out} \times iC_{4out} \%) ]}{(F_{in} \times iC_{4in} \%)} \times 100\% \quad (1)$$

$$\text{Sol} = \frac{[(F_{out} \times \text{ISOBUTENE}_{out} \%) ]}{[(F_{in} \times iC_{4in} \%) - (F_{out} \times iC_{4out} \%) ]} \times 100\% \quad (2)$$

$F_{in}$ : molar inlet flow rate       $M_{in}$ : massive inlet flow rate

$F_{out}$ : molar outlet flow rate       $iC_{4in} \%$ : molar percent of inlet isobutene

## RESULTS AND DISCUSSION

### 1. Characterization of Catalysts

The catalyst nomenclature, precursors, preparation method and metal content are represented in Table 1. Platinum and tin content were determined by ICP technique.

XRF analysis of catalysts is shown in Table 2. The results confirmed that SiO<sub>2</sub>/Al<sub>2</sub>O<sub>3</sub> ratios of synthesized Na-ZSM-5 as support were 40, 60 and 80 and loss on ignition (LOI) of these catalysts according to ASTM test method D 1208 were 3.8-4.5%.

The XRD pattern of Na-ZSM-5 (JCPDS: 42-0023), in three different SiO<sub>2</sub>/Al<sub>2</sub>O<sub>3</sub> ratios of 40, 60 and 80 (Fig. 1) shows that the SiO<sub>2</sub>/Al<sub>2</sub>O<sub>3</sub> ratio had no impact on the zeolite crystallinity. XRD patterns of Na-ZSM-5 before and after impregnation are shown in Fig. 2, which are similar to those for Na-ZSM-5, except for the peak related to the Pt in 2θ=39.8°. It was observed that the crystallinity of Sn/

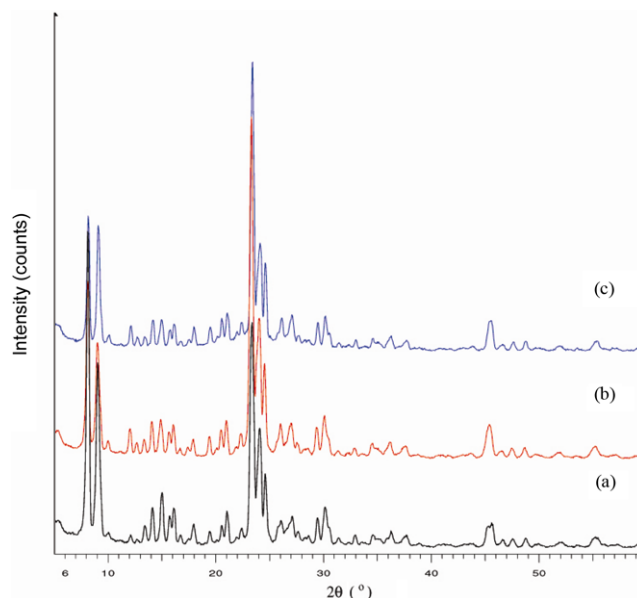

Fig. 1. XRD patterns of: (a) Na-ZSM-5(40), (b) Na-ZSM-5(60) and (c) Na-ZSM-5(80).

Pt/Na-ZSM-5 does not change after impregnation of metal.

XRD technique was used for identification and quantification of zeolite. Several reports are available on using XRD method for estimating crystallinity [26-28]. Crystallinity was estimated for the synthesized samples as follows: [10]

$$\frac{(\sum \text{Relative intensities of sample})}{(\sum \text{Relative intensities of standard})} \times 100\% \quad (3)$$

Therefore, the crystallinity percent of Na-ZSM-5 was estimated as 97.3% (Table 3).

The thermal behavior of the catalysts was studied in the range of 298-873 K in nitrogen atmosphere, and the heating rate of 10 K·min<sup>-1</sup> was used in TG/DTG technique. Final weight loss of the catalyst prepared by Na-ZSM-5 SiO<sub>2</sub>/Al<sub>2</sub>O<sub>3</sub>=40, 60 and 80 ratios was 4.23%, 3.84% and 4.53%, respectively, which is due to the dehydra-

Table 1. Characteristic of the synthesized catalysts

| Catalyst nomenclature                            | SiO <sub>2</sub> /Al <sub>2</sub> O <sub>3</sub> ratio | Sn precursor                         | Pt (wt%)  | Sn (wt%)  |
|--|--|--------------------------------------|-----------|-----------|
| Sn <sub>1</sub> /Pt <sub>1</sub> /Na-ZSM-5 (80)* | 80   | Bu <sub>3</sub> Sn(Cl)               | 0.51±0.02 | 0.60±0.04 |
| Sn <sub>1</sub> /Pt <sub>1</sub> /Na-ZSM-5 (60)* | 60   | Bu <sub>3</sub> Sn(Cl)               | 0.02±0.50 | 0.03±0.58 |
| Sn <sub>1</sub> /Pt <sub>1</sub> /Na-ZSM-5 (40)* | 40   | Bu <sub>3</sub> Sn(Cl)               | 0.50±0.02 | 0.59±0.03 |
| Sn <sub>1</sub> /Pt <sub>2</sub> /Na-ZSM-5 (40)* | 40   | Bu <sub>3</sub> Sn(Cl)               | 0.02±0.35 | 0.03±0.41 |
| Sn <sub>2</sub> /Pt <sub>1</sub> /Na-ZSM-5 (40)* | 40   | SnCl <sub>2</sub> ·2H <sub>2</sub> O | 0.50±0.02 | 0.59±0.03 |

\*Successive impregnation 1st Pt, 2nd Sn

Table 2. Results of XRF analysis of synthesized catalysts

| Catalyst  | Al <sub>2</sub> O <sub>3</sub> | SiO <sub>2</sub> | Na <sub>2</sub> O | PtO <sub>2</sub> | SnO <sub>2</sub> | LOI  |
|---|--------------------------------|------------------|-------------------|------------------|------------------|------|
| Sn <sub>1</sub> /Pt <sub>1</sub> /Na-ZSM-5 (80) | 1.50                           | 70.79            | 21.86             | 0.58             | 0.74             | 4.53 |
| Sn <sub>1</sub> /Pt <sub>1</sub> /Na-ZSM-5 (60) | 2.01                           | 70.95            | 21.91             | 0.57             | 0.72             | 3.84 |
| Sn <sub>1</sub> /Pt <sub>1</sub> /Na-ZSM-5 (40) | 2.95                           | 69.92            | 21.60             | 0.56             | 0.74             | 4.23 |
| Sn <sub>2</sub> /Pt <sub>1</sub> /Na-ZSM-5 (40) | 2.93                           | 69.90            | 21.60             | 0.57             | 0.73             | 4.27 |

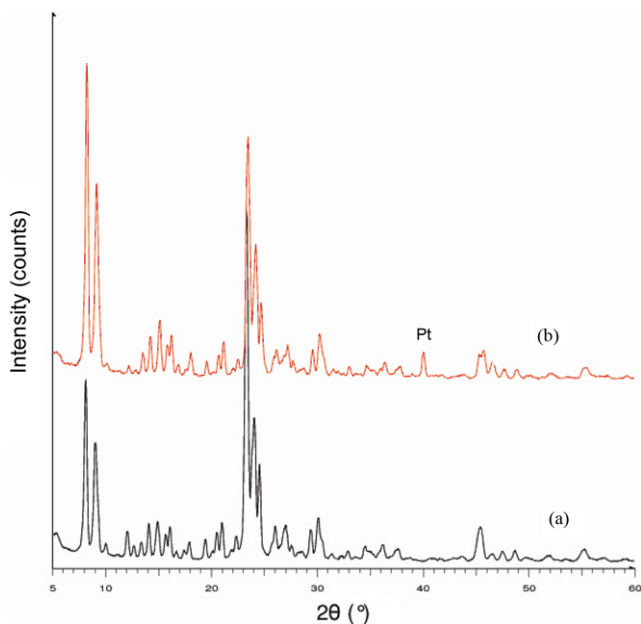

Fig. 2. XRD patterns of Na-ZSM-5 (a) before and (b) after impregnation.

Table 3. XRD data of synthesized catalyst

| Reference            | $2\theta$        | 23.172 | 23.302 | 7.944 | 23.971 | 7.954 |
|----------------------|------------------|--------|--------|-------|--------|-------|
|                      | I/I <sub>0</sub> | 100    | 79     | 63    | 48     | 47    |
| Synthesized Na-ZSM-5 | $2\theta$        | 23.249 | 23.403 | 8.003 | 23.993 | 8.005 |
|                      | I/I <sub>0</sub> | 100    | 77     | 62    | 46     | 45    |

tion of the samples. Up to 873 K, no more thermal event was observed. The XRD patterns of the samples heated at 873 K were unaltered. This confirms the thermal stability of products at this temperature.

In FT-IR spectra of catalysts, peaks of water adsorption appeared in 3,440 and 1,635  $\text{cm}^{-1}$  which are attributed to the stretching vibration of O-H and bending vibration of H-O-H, respectively. Asymmetric stretching vibration, symmetric stretching vibration, and bending vibration of T-O (T=Al or Si) appeared in the range of 1,000-1,150  $\text{cm}^{-1}$ , 550  $\text{cm}^{-1}$ , and 450  $\text{cm}^{-1}$ , respectively.

Hydrogen chemisorption was applied to measure the metal dispersion. Typically in the Chemisorptions' measurements, 0.5 g of catalyst was dried in flowing helium at 523 K for 1 h with subsequent evacuation at 323 K for 1 h. The samples were reduced in hydrogen at 673 K for 1 h, cooled down in hydrogen to 473 K, and evacuated for 1 h at this temperature. Subsequently, the samples were cooled to room temperature. The first isotherm was obtained at 308 K. The  $\text{H/Pt}_{\text{total}}$  ratios were determined based on the adsorbed amounts of hydrogen determined with this isotherm by extrapolation of the linear part to zero pressure. After the first isotherm was measured, the samples were evacuated at 308 K for 1 h and the second isotherm was obtained. The  $\text{H/Pt}_{\text{strong}}$  ratios were calculated by subtracting the ratios obtained from the second isotherms and the  $\text{H/Pt}_{\text{total}}$  ratios. Table 4 lists the  $\text{H/Pt}$  ratios determined for the catalysts. The ratios obtained in the first isotherm,  $\text{H/Pt}_{\text{total}}$ , and the ratios obtained after subtraction of the amount of removable hydrogen at 308 K,  $\text{H/Pt}_{\text{strong}}$ , vary significantly. However, the  $\text{H/Pt}_{\text{total}}$  ratio for each

Table 4. The  $\text{H/Pt}$  ratios and particle sizes of the catalysts

| Catalyst                                       | $\text{H/Pt}_{\text{total}}$ | $\text{H/Pt}_{\text{strong}}$ | Size of particle (nm) |
|--|------------------------------|-------------------------------|-----------------------|
| $\text{Sn}_1/\text{Pt}_1/\text{Na-ZSM-5}$ (80) | 0.37                         | 0.19                          | 8-12                  |
| $\text{Sn}_1/\text{Pt}_1/\text{Na-ZSM-5}$ (60) | 0.40                         | 0.21                          | 7-10                  |
| $\text{Sn}_1/\text{Pt}_1/\text{Na-ZSM-5}$ (40) | 0.46                         | 0.25                          | <4                    |
| $\text{Sn}_1/\text{Pt}_2/\text{Na-ZSM-5}$ (40) | 0.29                         | 0.16                          | <4                    |
| $\text{Sn}_2/\text{Pt}_1/\text{Na-ZSM-5}$ (40) | 0.42                         | 0.23                          | 5-8                   |

catalyst is about twice as high as the  $\text{H/Pt}_{\text{strong}}$  ratio indicating that the correlation with Pt surface area is the same for both numbers.

Although quantification of the platinum surface sites on the basis of hydrogen chemisorptions results is controversial, the observed difference in  $\text{H/Pt}$  ratio for different catalysts must be due to a difference in dispersion. The  $\text{Sn}_1/\text{Pt}_1/\text{Na-ZSM-5}$ (40) catalyst had the highest dispersion of Pt.

Fig. 3 shows the transmission electron micrographs of catalysts. TEM analysis of the Sn/Pt on Na-ZSM-5 catalysts showed the platinum to be well dispersed in the  $\text{Sn}_1/\text{Pt}_1/\text{Na-ZSM-5}$ (40) catalyst. These distributions suggest that the Pt particles in both  $\text{Sn}_1/\text{Pt}_1/\text{Na-ZSM-5}$ (40) and  $\text{Sn}_1/\text{Pt}_2/\text{Na-ZSM-5}$ (40) catalysts are of the same size, which is less than 4 nm.

The TEM images of the  $\text{Sn}_2/\text{Pt}_1/\text{Na-ZSM-5}$ (40),  $\text{Sn}_1/\text{Pt}_1/\text{Na-ZSM-5}$ (60) and  $\text{Sn}_1/\text{Pt}_1/\text{Na-ZSM-5}$ (80) catalysts indicate that the metal nanoparticles in these systems are unevenly distributed with an average particle size represented in Table 4. Moreover, the number of metal nanoparticles per gram of  $\text{Sn}_1/\text{Pt}_1/\text{Na-ZSM-5}$ (40) catalyst is higher than the others.

The lower  $\text{SiO}_2/\text{Al}_2\text{O}_3$  ratio in support leads to higher number of acidic sites, which then causes uniform distribution of the active phase, Pt, on the surface of support, and therefore the selectivity of catalysts is decreased. Thus, the  $\text{Sn}_1/\text{Pt}_1/\text{Na-ZSM-5}$ (40) and  $\text{Sn}_1/\text{Pt}_1/\text{Na-ZSM-5}$ (80) catalysts have the highest and lowest distribution of Sn/Pt nanoparticles on their surfaces, respectively.

The comparison of the  $\text{Sn}_1/\text{Pt}_1/\text{Na-ZSM-5}$ (40) and  $\text{Sn}_2/\text{Pt}_1/\text{Na-ZSM-5}$ (40) catalysts with two different tin precursors suggests that a higher distribution of Sn/Pt is achieved by using the  $\text{Bu}_3\text{Sn}(\text{Cl})$ . The comparison of the  $\text{Sn}_1/\text{Pt}_1/\text{Na-ZSM-5}$ (40) and  $\text{Sn}_1/\text{Pt}_2/\text{Na-ZSM-5}$ (40) catalysts with two different amounts of Pt, 0.5 and 0.35%, respectively, shows that the higher amount of Pt improves the selectivity to isobutene.

SEM/EDX analysis of catalysts indicates that bimetallic nanoparticles of Sn/Pt were formed in all catalysts.

Homogeneous dispersion of the metallic clusters on the support is provided by using the impregnation method. In this manner, the active phase must be in a sufficiently high dispersed form, which results in a large specific surface area, and consequently in a maximum specific activity [19]. This property is inherent to ZSM-5 and related to the fact that the pores of ZSM-5 are too large to obtain a high selectivity to isobutane dehydrogenation [29]. For the preparation of highly dispersed Sn/Pt nanoparticles in Na-ZSM-5 the heating rate must be low. The ZSM-5 micropores might well be able to stabilize the mobile Pt species [30].

## 2. Dehydrogenation of Isobutane into Isobutene

The inlet isobutane was composed of  $\text{CH}_4=0.05\%$ ,  $\text{C}_2\text{H}_6=0.08\%$ ,

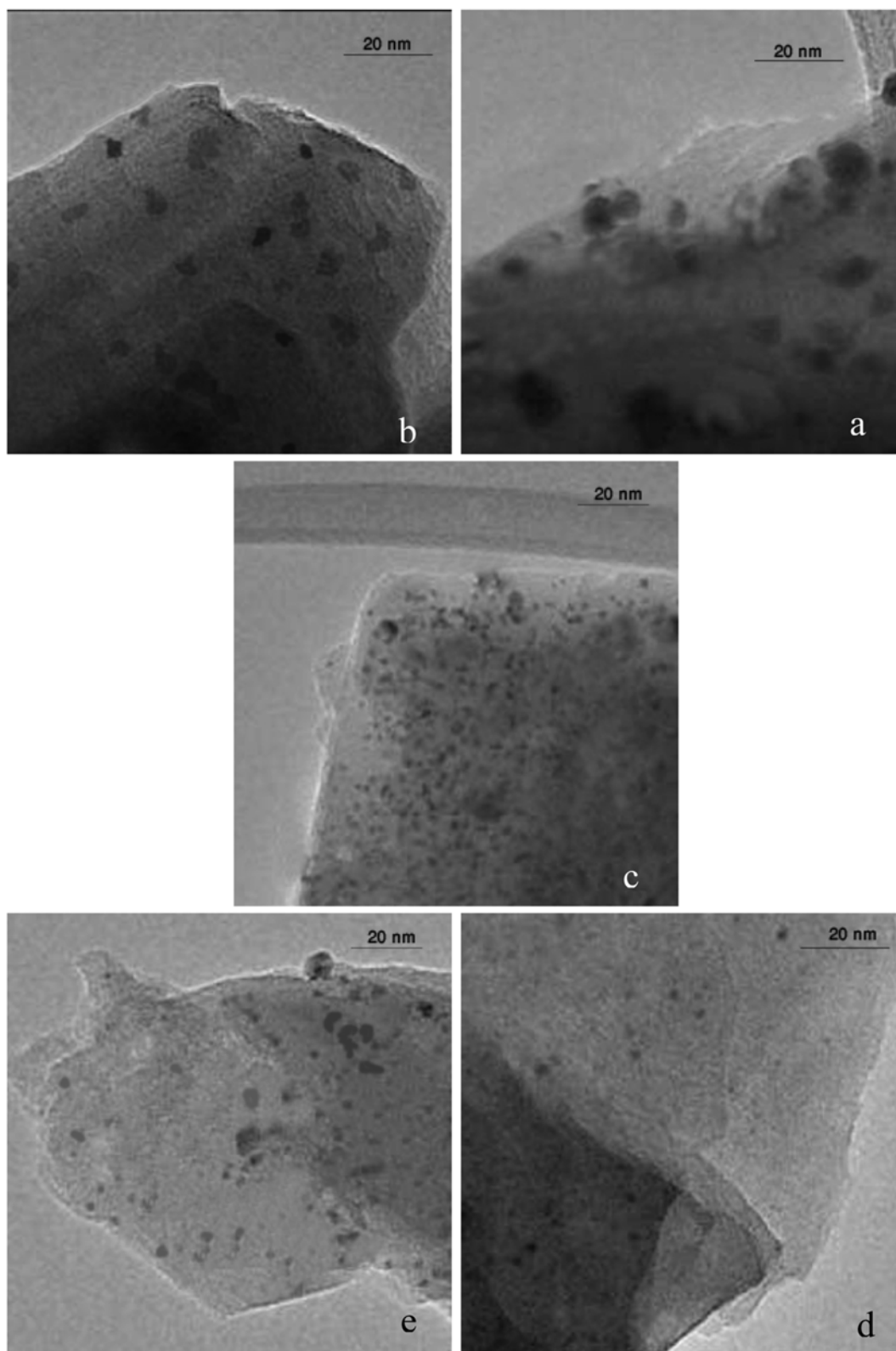

**Fig. 3.** TEM images of catalysts, (a)  $\text{Sn}_1/\text{Pt}_1/\text{Na-ZSM-5(80)}$ , (b)  $\text{Sn}_1/\text{Pt}_1/\text{Na-ZSM-5(60)}$ , (c)  $\text{Sn}_1/\text{Pt}_1/\text{Na-ZSM-5(40)}$  (d)  $\text{Sn}_1/\text{Pt}_2/\text{Na-ZSM-5(40)}$  and (e)  $\text{Sn}_2/\text{Pt}_1/\text{Na-ZSM-5(40)}$  catalysts.

$\text{C}_3\text{H}_6=0.89\%$ ,  $i\text{C}_4=98.65\%$ ,  $n\text{C}_4=0.34\%$ . After dehydrogenation reaction, the conversion, selectivity and yield of the product were calculated, according to the product analyses.

The reaction was studied in the range of 773 to 873 K. The experimental conditions (WHSV) were fixed such that the conversions were low and not limited by the thermodynamics (Fig. 4). Extrapolation

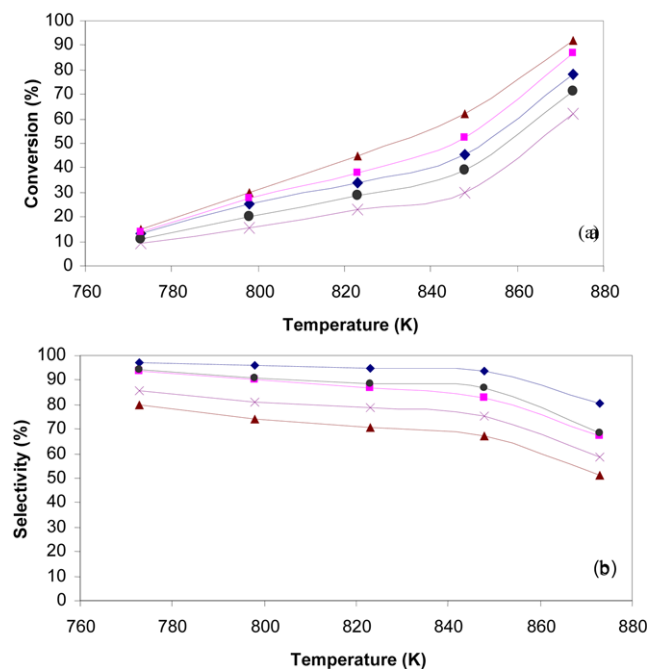

Fig. 4. Conversion (a) and selectivity (b) of  $\text{Sn}_1/\text{Pt}_1/\text{Na-ZSM-5(80)}$  ( $\blacktriangle$ ),  $\text{Sn}_1/\text{Pt}_1/\text{Na-ZSM-5(60)}$  ( $\blacksquare$ ),  $\text{Sn}_1/\text{Pt}_1/\text{Na-ZSM-5(40)}$  ( $\blacklozenge$ ),  $\text{Sn}_1/\text{Pt}_2/\text{Na-ZSM-5(40)}$  ( $\times$ ) and  $\text{Sn}_2/\text{Pt}_1/\text{Na-ZSM-5(40)}$  ( $\bullet$ ) catalysts in the range of 773–873 K.

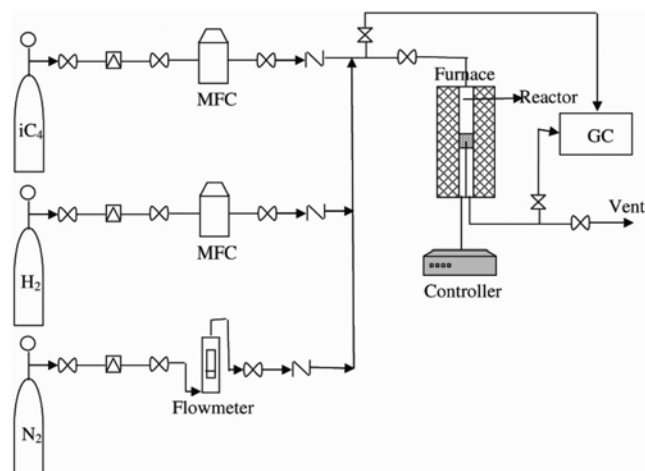

Fig. 5. Schematic of reactor testing system.

olation of the data gives the thermodynamic conversion value of the catalysts.

Dehydrogenation reaction was carried out in the presence of hydrogen and isobutane under the following conditions:

catalyst weight (2 g) temperature reaction (848 K); pressure (1 atmosphere), isobutane/hydrogen molar ratio was 2/1 and WHSV ( $2.5 \text{ h}^{-1}$ ).

Fig. 5 depicts the schematic design of the reactor testing system used for dehydrogenation of isobutane. This system was designed and constructed at the Petrochemical Research Company (Tehran, Iran). All of the connecting lines were made by stainless steel. A quartz tube was used as reactor with 60 cm length and 10 mm diam-

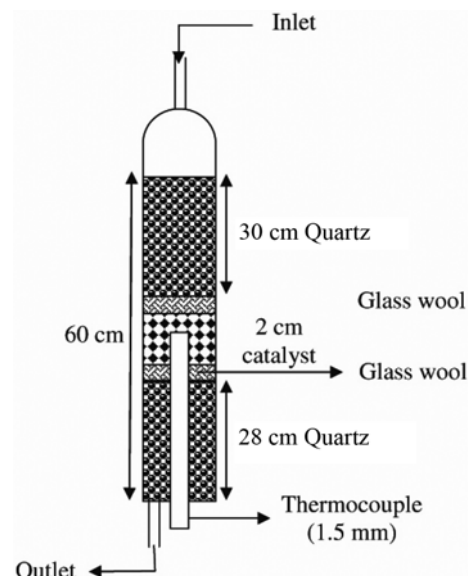

Fig. 6. Schematic of quartz reactor.

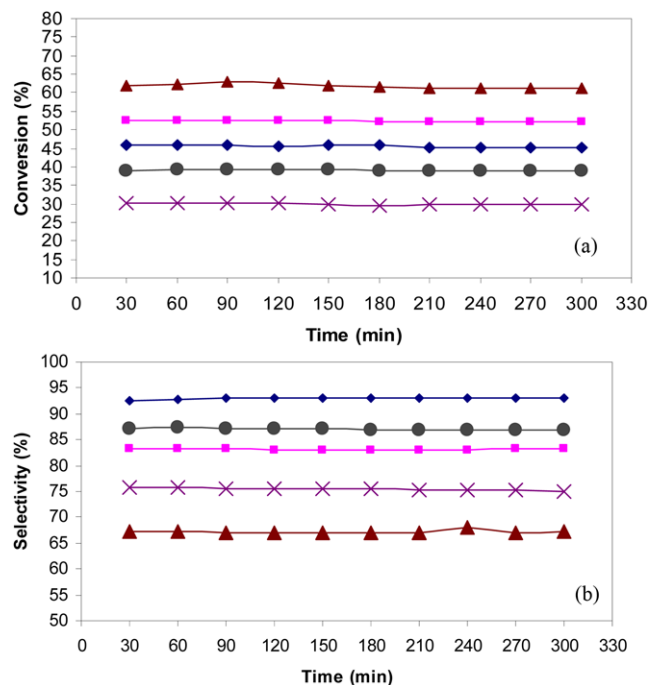

Fig. 7. Conversion (a) and Selectivity (b) of  $\text{Sn}_1/\text{Pt}_1/\text{Na-ZSM-5(80)}$  ( $\blacktriangle$ ),  $\text{Sn}_1/\text{Pt}_1/\text{Na-ZSM-5(60)}$  ( $\blacksquare$ ),  $\text{Sn}_1/\text{Pt}_1/\text{Na-ZSM-5(40)}$  ( $\blacklozenge$ ),  $\text{Sn}_1/\text{Pt}_2/\text{Na-ZSM-5(40)}$  ( $\times$ ) and  $\text{Sn}_2/\text{Pt}_1/\text{Na-ZSM-5(40)}$  ( $\bullet$ ) catalysts.

eter (Fig. 6).

The conversion, selectivity and yield of isobutane dehydrogenation are calculated and represented in Fig. 7.

It is known that catalysts with higher Pt distribution show higher selectivity to isobutene and produce smaller amounts of other products [31].

The selectivity is clearly related to the ratio of Brønsted acid sites to accessible metal atoms. At a constant acid site concentration, the selectivity to isobutene increases with metal loading. At a constant

**Table 5. Comparison with other catalysts**

| Catalyst  | Conversion (%) | Selectivity (%) | Ref   |
|---|----------------|-----------------|-------|
| Sn <sub>1</sub> /Pt <sub>1</sub> /Na-ZSM-5 (80) | 61.5           | 67.2            | ----  |
| Sn <sub>1</sub> /Pt <sub>1</sub> /Na-ZSM-5 (60) | 52.2           | 83.1            | ----- |
| Sn <sub>1</sub> /Pt <sub>1</sub> /Na-ZSM-5 (40) | 45.4           | 92.5            | ----  |
| Sn <sub>1</sub> /Pt <sub>2</sub> /Na-ZSM-5 (40) | 29.9           | 75.3            | ----- |
| Sn <sub>2</sub> /Pt <sub>1</sub> /Na-ZSM-5 (40) | 39.0           | 87.1            | ----- |
| Pt/Na-[Fe]-ZSM-5                                | 10-20          | 96.5-98.6       | 32    |
| Pt-[In]-ZSM-5                                   | 36             | 98              | 33    |
| Pt/Na-ZSM-5                                     | 27.7           | 84.5            | 34    |
| Sn <sub>1</sub> /Pt/Na-Y                        | 30             | 89.7            | 35    |
| Sn <sub>2</sub> /Pt/Na-Y                        | 39.5           | 74.5            | 35    |
| PtSn/SiO <sub>2</sub>                           |                | 98              |       |
| PtSn/Al <sub>2</sub> O <sub>3</sub>             | 10             | 92              | 17    |
| PtSn/SiO <sub>2</sub>                           |                | 92              |       |
| PtSn/Al <sub>2</sub> O <sub>3</sub>             | 13             | 72              | 36    |
| PtSn/MgO  |                | 99              |       |
| Pt/Sn/ $\gamma$ -Al <sub>2</sub> O <sub>3</sub> | 15             | 87              | 37    |

metal loading, the selectivity to isobutene increases with decreasing acid site concentration. Sn<sub>1</sub>/Pt<sub>1</sub>/Na-ZSM-5(40) catalyst has shown higher selectivity than the Sn<sub>1</sub>/Pt<sub>1</sub>/Na-ZSM-5(80) because of the higher Pt distribution.

The results (Fig. 7) show that the trend in the selectivity pattern follows closely the trend in the ratio between accessible Pt surface atoms and acid sites. Note that the highest selectivity of isobutene was achieved with the Sn<sub>1</sub>/Pt<sub>1</sub>/Na-ZSM-5(40) catalyst with the highest ratio of metal to acid sites.

The TEM measurements indicate that the samples with lower SiO<sub>2</sub>/Al<sub>2</sub>O<sub>3</sub> ratio had smaller Pt particles. If large Pt particles are present on the surface of the zeolite, the amount of Pt on the surface will be high, but the fraction of accessible metal sites will be low.

The high selectivity of catalysts in dehydrogenation could be related to the small size of the metal particles, as observed in TEM. The selectivity to dehydrogenation is expected to be higher for small Pt particles. Indeed, the highest selectivity to dehydrogenation was found for Sn<sub>1</sub>/Pt<sub>1</sub>/Na-ZSM-5(40) with the smallest Pt particles, while Sn<sub>1</sub>/Pt<sub>1</sub>/Na-ZSM-5(80) with larger particles has lower selectivity to dehydrogenation.

Table 5 demonstrates the effectiveness of this catalyst with that of the previously reported catalysts. As it can be seen from the table, our catalysts are superior in terms of conversion and yields.

## CONCLUSIONS

Sn/Pt/Na-ZSM-5 catalysts were prepared with different SiO<sub>2</sub>/Al<sub>2</sub>O<sub>3</sub> ratios, different amounts of Pt and different Sn precursors over Na-ZSM-5, by sequential impregnation, at first Pt and then Sn. The results show that the synthesized catalysts are stable up to 873 K, which is higher than operational temperature. The conversion and selectivity of isobutane dehydrogenation showed that Sn<sub>1</sub>/Pt<sub>1</sub>/Na-ZSM-5(40) catalyst had higher selectivity as compared to Sn<sub>1</sub>/Pt<sub>1</sub>/Na-ZSM-5(60) and Sn<sub>1</sub>/Pt<sub>1</sub>/Na-ZSM-5(80) catalysts. Increasing the SiO<sub>2</sub>/Al<sub>2</sub>O<sub>3</sub> ratio led to reduced number of acidic sites and

selectivity, that due to non-uniform distribution of Pt on the surface of support.

It is believed that the presence of tin in the catalyst surface enhances formation of Sn-Pt particles and prevents formation of local platinum clusters. The Sn-Pt also prevents the association of dehydrogenated products on the catalyst surface, which competes with main reactants and causes coke formation [19].

The results also show that when higher Pt amounts in the catalyst with SiO<sub>2</sub>/Al<sub>2</sub>O<sub>3</sub> ratio of 40 were used a higher selectivity of the catalyst to isobutene was obtained.

## ACKNOWLEDGEMENTS

The authors wish to thank the Office of Graduate Studies of the University of Isfahan for their support. This research was partially performed at the Iranian Petrochemical Research Company. We are grateful for the company's support. The authors thank Mrs. M. Akbari for his help in the XRD analysis in Central Laboratory, University of Isfahan, Mr. R. Sayyari for help in the ICP analysis and Mr. M. Alizadeh for help in the FT-IR analysis in Islamic Azad University, Shahreza branch.

## REFERENCES

1. E. O. Box, L. E. Drehman and F. Farha, German Patent, 2,127,353 (1970).
2. M. E. Olbrich, D. L. McKay and D. P. Montgomery, US Patent, 4,926,005 (1989).
3. F. Wilhelm, Dutch Patent, 2,164,295 (1972).
4. F. C. Wihelm, US Patent, 3,755,480 (1973).
5. D. E. Resasco and G. L. Haller, *Catal.*, **11**, 379 (1994).
6. T. Hutson Jr. and W. C. McCarthy, in *Handbook of petroleum refining processes*, R. A. Meyers Eds., McGraw-Hill, London (1986).
7. P. R. Pujado and B. V. Vora, *Hydrocarbon Process*, March 65 (1990).
8. G. F. Hornaday, F. M. Ferrell and G. A. Mills, *Adv. Petrol. Chem. Refining*, **4**, 451 (1961).
9. S. Srihiranpullo and P. Prasertdam, *Korean J. Chem. Eng.*, **20**, 1017 (2003).
10. B. JR William C and R. Kenneth L, US Patent, 4,966,880 (1990).
11. W. Robert G, US Patent, 5,609,751 (1997).
12. G. John M and H. John W, US Patent, 5,516,741 (1996).
13. I. Tamotsu and A. Hayim, US Patent, 4,786,625 (1988).
14. J. H. Sinfelt, *Bimetallic catalysts: Discoveries, concepts and applications*, Wiley, New York (1983).
15. R. Srinivasan and B. H. Davis, *Platinum Met. Rev.*, **36**, 151 (1992).
16. H. Lieske, A. Sarkany and J. Volter, *Appl. Catal.*, **30**, 69 (1987).
17. F. Z. Bentahar and J. P. Canday, *Catal. Today*, **66**, 303 (2000).
18. Z. Nawaz, T. Xiaoping and F. Wei, *Korean J. Chem. Eng.*, **26**, 1528 (2009).
19. F. Pinna, *Catal. Today*, **41**, 129 (1998).
20. Y. Zhang, Y. Zhou, A. Qiu, Y. Wang, Y. Xu and P. Wu, *Catal. Commun.*, **7**, 862 (2006).
21. T. Waku, J. A. Biscardi and E. Iglesia, *J. Catal.*, **222**, 481 (2004).
22. Y. Zhang, Y. Zhou, A. Qiu, Y. Wang, Y. Xu and P. Wu, *Acta Phys. Chim. Sin.*, **22**, 672 (2006).
23. M. Ghiaci, F. Seyedeyn-Azad and R. Kia, *Mater. Res. Bull.*, **39**, 1257 (2004).

24. R. D. Cortright and J. M. Hill, *Catal. Today*, **55**, 213 (2000).
25. M. A. Centeno, M. Debois and P. Grange, *J. Catal.*, **192**, 296 (2000).
26. S. S. Rayalu, J. S. Udhoji, S. U. Meshram, R. R. Naidu and S. Devotta, *Curr. Sci.*, **89**, 2147 (2005).
27. S. R. Stojkovic and B. Adnadjevic, *Zeolites*, **6**, 523 (1988).
28. A. Bhattacharya, J. Das, S. Mitra and S. K. Roy, *J. Chem. Technol. Biotechnol.*, **54**, 399 (1992).
29. G. D. Pirngruber, IOP Katalyse, no. IKA 94023, 49 (1999).
30. J. de Graaf, A. J. van Dillen, K. P. de Jong and D. C. Koningsberger, *J. Catal.*, **203**, 307 (2001).
31. S. Scire, G. Burgio, C. Crisafulli and S. Minicò, *Appl. Catal., A: Gen.*, **274**, 151 (2004).
32. T. Waku, J. A. Biscardi and E. Iglesia, *Chem. Commun.*, 1764 (2003).
33. Indo French Center for the Promotion of Advanced Research, FR Patent, 2,724,926 (1996).
34. M. P. Kaminsky, G. F. Froment and W. J. DeHertog, WO Patent 93/15835 (1993).
35. S. Vaezifar, H. Faghihian and M. Kamali, *Iran. J. Chem. & Chem. Eng.*, **28**, 23 (2009).
36. C. Berger, R. Gläser, R. A. Rakoczy and J. Weitkamp, *Micropor. Mesopor. Mater.*, **83**, 333 (2005).
37. S. Vaezifar, H. Faghihian and M. Kamali, *J. Iran. Chem. Res.*, **1**, 19 (2008).