

Simulation of mass exchange networks using modified genetic algorithms

Jutamart Thunyawart*, Thongchai Srinophakun****†, and Waranya Henwatthana**

*Department of Chemical Engineering, Kasetsart University, Bangkok 10900, Thailand

**Department of Chemical Engineering, King Mongkut's University of Technology Thonburi, Bangkok 10140, Thailand

***National Center of Excellence for Petroleum, Petrochemicals, and Advanced Materials,
Pathumwan, Bangkok 10330, Thailand

(Received 10 March 2010 • accepted 16 June 2010)

Abstract—The optimum water usage network leads to both a minimum of freshwater consumption and a minimum of generated wastewater. This work is to develop a mass-exchange networks (MENs) module for a minimum freshwater usage target. This module works as an interface to retrieve supplemental data of chemical processes from a process simulator and to communicate this to the genetic algorithm optimizer. A reuse system and a regeneration/recycling system with a single contaminant are considered as approaches for freshwater minimization. In the formulated model, as mixed integer nonlinear programming (MINLP), all of the variables are divided into independent and dependent variables. The values of independent variables come from randomization, whereas the values of dependent variables come from simultaneous solutions of a set of equality constraints after assigning the values of independent variables. This method is applied to the steps of initialization, crossover and mutation. The MENs module is validated with a tricresylphosphate process consisting of five unit operations. Water is used to remove a fixed content of cresol. From the result, the module gives a reliable solution for freshwater minimization, which can satisfy mass balance and constraints. The results show that reuse and regeneration/recycling strategies can reduce freshwater consumption, including wastewater generated. Reuse cannot decrease the mass load of the contaminant, while regeneration/recycling can. In addition, regeneration requires less freshwater than the reuse process.

Key words: Wastewater Minimization, Genetic Algorithm, Mixed Integer Nonlinear Programming

INTRODUCTION

A chemical process, an integrated system of interconnected units and streams, typically discharges wastewater and releases pollution into the environment. The goals of process integration are to fundamentally understand the global nature of the process, to methodically determine the performance targets, and to systematically make decisions leading to the realization of those targets. Process integration can be divided into mass integration and heat integration, but only mass integration will be addressed in this work as an approach to minimum freshwater consumption. Moreover, it achieves cost effectiveness, yield enhancement and energy efficiency of processes in plants.

Wang and Smith [1] addressed the case study of minimization of wastewater in a petroleum refinery. Through reuse, the cost of freshwater consumption and wastewater treatment could be reduced 20%. Adding a regeneration process without recycling reduced freshwater and wastewater flowrates by nearly 60%, and reduced costs by over 60%. El-Halwagi and Manousiouthakis [2] presented a two-stage automated procedure. This procedure formulated a mixed-integer linear programming (MILP) transshipment and then used it to synthesize all possible networks and to determine the minimum number of units. Among the completed networks, the one with the lowest cost was selected. This was carried out iteratively for the range of a minimum allowable composition difference (ϵ) to minimize the annualized total cost of the network. The main weak point

of this procedure is its sequential approach. Capital and operating costs are not considered simultaneously, which means that the correct trade-off between these costs is unlikely to be found. Papalexandri et al. [3] later developed a procedure based on mixed-integer nonlinear programming (MINLP) to overcome the limitation of the sequential procedure in linear programming. They generated a network hyperstructure containing many network alternatives to present the MENs. Optimization is done based on this hyperstructure in order to obtain a minimum total annual cost (TAC). Formerly, Floudas [4] developed the simultaneous match-network hyperstructure (superstructure) model for optimizing all of the capital costs of a heat exchanger network. MINLP formulation was used to determine the minimum costs for exchanger units and exchanger area by combining the transshipment model of Yee and Grossmann [5] for stream matching and network topology. As the complexity of the formulated problem, the solution for inherently nonlinear behavior is approached by genetic algorithms.

Garrard and Fraga [6] introduced an approach to the synthesis problem of MENs and MENs with regeneration using genetic algorithms (GAs) to find a network. This approach has been able to solve the inherently nonlinear and nonconvex problem both effectively and with optimal consistency. Suriyaprapadilok [7] formulated nonlinear programming (NLP) to solve for the optimum water-using network in a tapioca plant. At the optimum, freshwater consumption is minimized a 13.22% reduction of freshwater usage was obtained. Krirkkrajijjorn [8] introduced the concept of a simultaneous heat- and mass-exchange networks technique for multi-components to eliminate unsatisfied substances out of process streams through

†To whom correspondence should be addressed.
E-mail: fengtcs@hotmail.com

pinch analysis. The temperature of rich streams is exchanged with mass-separation agents in order to reach the equilibrium temperature where maximum mass exchange occurs. A user interface program was developed to link with GAMs [9]. When the equilibrium temperature was considered, mass exchange between rich and lean streams became more sensible. In addition, the equilibrium equations between rich and lean streams can provide a more reliable result because of the accuracy of heat and mass balance calculation. Prakotpol [10] developed a genetic algorithm (GA) on MATLAB™ for solving the wastewater minimization problem. In a single-contaminant system, the GA approach and Lingo [11] can find the minimum freshwater consumption, but the solutions are different in the configuration of a water usage network. In a multiple-contaminants system, the GA approach can find the same or better results in some test problems. In this paper, we propose a modified GA and apply to mass exchanger networks.

METHODOLOGY

Mathematical optimization models representing a single-contaminant water reuse system and a single-contaminant regeneration/recycling system will be formulated for designing a water use network for the process. For a single-contaminant water reuse system and a single-contaminant regeneration/recycling system minimizing freshwater usage, the optimization is carried out using an improved genetic algorithm (GA). GAs are one of the best ways to solve an optimization problem. They use selection and evolution to produce several solutions to a given problem. GAs tend to thrive in an environment in which there is a very large set of candidate solutions and in which the search space is uneven and has many hills and valleys. They do well in any environment but are not always the best choice. Sometimes, they can take a long time to run, and hence are not always feasible for real-time use. However, they are one of the most powerful methods which quickly create high-quality solutions to a problem.

GAs are a procedure of breeding a computer program and solutions to optimization by means of simulated evolution processes based on natural selection by repeated crossover and mutation.

The procedure for GAs is summarized in the following steps:

1. Choose a random initial population.
2. Evaluate each chromosome's fitness and determine the population's average fitness.
3. Repeat.
 - Select the best-ranking individuals to reproduce.
 - Apply a crossover and mutation operator.
 - Determine the population's average fitness until a termination condition is reached.

In 2000, Wasanapradit's work [12] developed a new effective method of genetic algorithms to solve the general MINLP problem. The specific methods for each step of GAs are as follows.

1. Real Number Representation

Real number representation is used to represent the solutions. For example, the solution has four variables: $x_1=20.22$, $x_2=1.55$, $x_3=0$, $x_4=5.09$. The vector that represents this solution is $\langle 20.22 \ 1.55 \ 0 \ 5.09 \rangle$.

2. Arithmetical Crossover

Arithmetical crossover is defined as a linear combination of two

vectors. For example, if v_1 and v_2 are selected to undergo a crossover, then the offspring can be calculated from Eqs. (1) and (2):

$$v'_1 = a \cdot v_1 + (1-a) \cdot v_2 \quad (1)$$

$$v'_2 = a \cdot v_2 + (1-a) \cdot v_1 \quad (2)$$

$$v_1 = [5.22 \ 14.05] \quad v_2 = [9.95 \ 4.31]$$

$$a = 0.4$$

$$v'_1 = 0.4[5.22 \ 14.05] + (1-0.4)[9.95 \ 4.31]$$

$$= [8.058 \ 8.206]$$

$$v'_2 = [7.112 \ 10.154]$$

3. Transformation-based Mutation

By transformation-based mutation, a chromosome is selected from the positions of genes undergoing mutation randomly. After that, these genes are replaced with new values between the lower and upper bounds of those genes.

4. Repair Strategy

Repair strategy is used to convert infeasible solutions to feasible ones. To repair any solution, the feasibility of the solution is calculated first by Eq. (3):

$$S(x) = \max(g(x) - b_i) \quad (3)$$

where $g(x)$ is the set of inequality constraints that has the right-hand-side term b_i . The general form of inequality constraints is:

$$g(x) \geq b_i$$

The values of $S(x)$ can be minus, positive or zero. A minus $S(x)$ means the solution is feasible it stays in the area of feasibility of the problem. A positive sign means the solution cannot satisfy the inequality constraints and is an infeasible solution. A zero value of $S(x)$ means the solution lies on the constraint boundary.

The purpose of a repair algorithm is to convert a solution that has $S(x) \geq 0$ to one that has $S(x) = 0$. Such a procedure corresponds to the root finding of an equation with a numerical method. Therefore, a secant method incorporating a bisection method was modified to achieve this goal. The secant method was selected because of its high speed in finding the root of an equation. However, it can diverge when the initial points are not suitable. Thus, the bisection method, a promising but slower method, was combined in order to find suitable new initial points for the secant.

Secant and bisection methods can calculate new solutions by using Eqs. (4) and (5), respectively:

$$x_{i+1} = x_i - \frac{S(x_i)(x_{i-1} - x_i)}{S(x_{i-1}) - S(x_i)} \quad (4)$$

$$x_{i+1} = \frac{x_{i-1} + x_i}{2} \quad (5)$$

The procedure of the program combining the secant method with the bisection method is given in Fig. 1.

5. Cross-generation Probabilistic Survival Selection (CPSS)

CPSS is a selection method that can maintain the diversity of a population. This method was developed to prevent a premature convergence problem in traditional GAs. With CPSS, a selection possibility does not depend on the fitness of the solution only. It also depends on the structure of the solution. The selection probability for each solution can be calculated using Eq. (6):

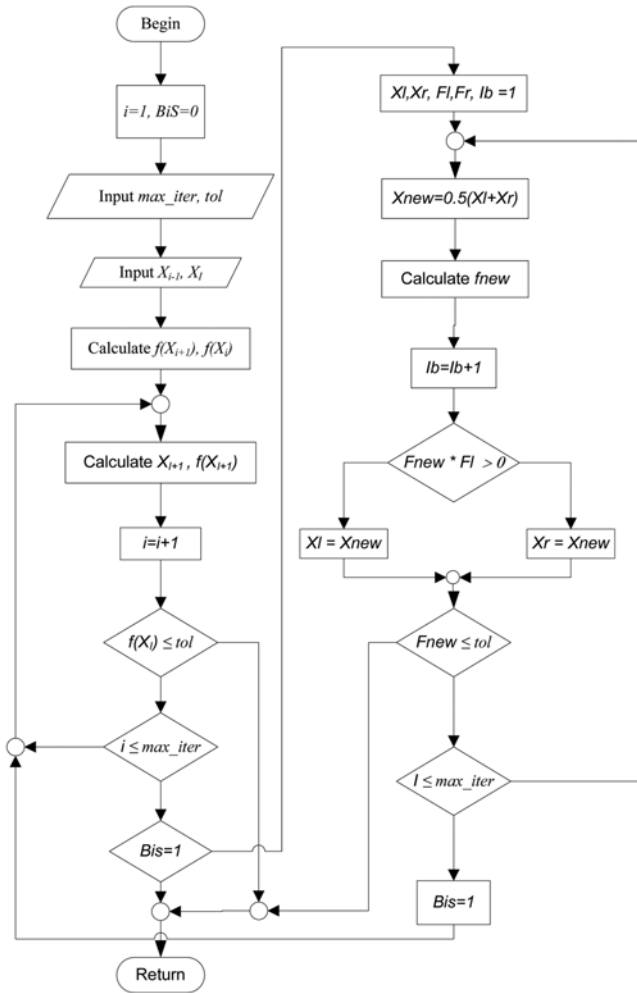

Fig. 1. Algorithm of the secant method combined with bisection [Prakotpol, 2001].

$$p_s = \left\{ (1-m) \frac{h}{L} + m \right\}^\alpha \tag{6}$$

where h is the hamming distance between the candidate solution and the solution with the best fitness value, L is the length of the string representing the chromosome, m is the shape coefficient, and α is the exponent.

The hamming distance (h) can be calculated by the equation:

$$h = \sqrt{(v_1 - v'_1)^2 + \dots + (v_k - v'_k)^2} \tag{7}$$

where v_i and v'_i are genes of the candidate solution and the fittest solution.

The length of the string representing the solution (L) can be expressed as follows:

$$L = \max(h_j); \quad j = 1, \dots, \text{number of population}$$

For mixed-integer problems, the calculation of h and L must be separated between real and integer variables. After that, the results are combined with a weight factor. Therefore, h and L for mixed-integer problems can be determined using the following equations:

$$h = w \cdot h_R + (1-w)h_I \tag{8}$$

$$L = w \cdot L_R + (1-w)L_I \tag{9}$$

where w is the weight factor. Its value depends on the importance of variables. In this work, a value of 0.5 for the weight factor is used. The subscripts R and I indicate real and integer variables, respectively. The procedure of CPSS is as follows:

- 1) Eliminate duplicated structures (new population) from the combined population of parents and offspring.
- 2) The best solution is kept first.
- 3) Calculate a selection probability (p_s) for each solution.
- 4) Generate a random number for each solution. If the generated random number is smaller than p_s , the solution is selected. Otherwise, it is deleted.
- 5) If the number of the current population is smaller than the population size, new structures are generated randomly because of the insufficient number. If the number of the current population is greater than the population size, the fitter ones are selected.

The objective of this study is to develop an MENs module for Aspen Plus. This study uses two strategies, water reuse and regeneration/recycling, to address the water-using network when a single contaminant is present. The assumptions of the MENs module for Aspen Plus are defined as:

- (1) Only a single contaminant is considered.
- (2) The mass-separating agent (MSA) is water only.
- (3) No equilibrium relationship governs the distribution of the contaminant in water.
- (4) The outlet concentration of any unit operation is equal to the limiting outlet concentration in order to maximize water reuse.
- (5) Mass load of the contaminant in any unit operation is constant.

The methodology is divided into three steps: 1) freshwater minimization through genetic algorithm 2) construction of an MENs module for minimum freshwater target and 3) testing the MENs module.

6. Freshwater Minimization through Genetic Algorithm

6-1. Degree of Freedom (DOF) for Single-contaminant Water Reuse Model

For the freshwater minimization problem, all of the variables can be divided into three groups:

- (1) Freshwater flowrate (F_i)
- (2) Wastewater flowrate (W_i)
- (3) Reused water flowrate ($X_{i,j}$)

In this model, the possible number of freshwater and wastewater stream is equal to the number of unit operations, as shown in the following matrices:

$$F = [F_1, F_2, \dots, F_N]$$

$$W = [W_1, W_2, \dots, W_N]$$

Therefore, there are 2N variables that represent the flowrate of these streams, and there are $N^2 - N$ variables that represent the flowrates of the reused water streams. All of the possible reused streams from any operation to the others can be represented by this matrix:

$$X = \begin{bmatrix} 0 & X_{1,2} & X_{1,3} & \dots & X_{1,N} \\ X_{2,1} & 0 & X_{2,3} & \dots & X_{2,N} \\ X_{3,1} & X_{3,2} & 0 & \dots & X_{3,N} \\ \vdots & \vdots & \vdots & \dots & \vdots \\ X_{N,1} & X_{N,2} & X_{N,3} & \dots & 0 \end{bmatrix}$$

Hence, the total number of variables is $N-N+N^2-N=N^2-N$ variables.

The optimization model of this process contains N equality constraints from water balance and N equality constraints from contaminant balance around each operation. Hence, there are $2N$ equations of N^2+N variables. If the values of N^2-N variables representing the flowrates of the reused streams are fixed, the rest of the $2N$ variables can be determined by solving the independent $2N$ equations from the material balance simultaneously. Thus, the flowrates of reused streams are selected to be the independent variables from randomization by GAs. The remainders are the dependent variables that are the solution of the equality constraints after assigning the random value of independent variables.

6-2. Degree of Freedom (DOF) for Single-Contaminant Regeneration/Recycling

When the regeneration process is considered, there are $2N$ variables more than water reuse without regeneration. These added variables are the flowrate of wastewater streams from each operation to the regeneration process, and regenerated water to each operation. These variables can be represented by the following matrix:

$$R = \begin{bmatrix} R_{1,r} & R_{r,1} \\ R_{2,r} & R_{r,2} \\ \vdots & \vdots \\ R_{N,r} & R_{r,N} \end{bmatrix}$$

In the regeneration/recycling process, there are $2N+1$ equality constraints adding the mass balance around the regeneration process. The total variables are $N+N+(2N-N)+2N=2N+3N$. In this case, the flowrate of reused water streams (N^2-N variables) and the variables in the matrix R ; except R_r , N ($2N-1$ variables) are selected to be the independent variables. Therefore, the values of independent variables ($2N+N-1$ variables) have to be known before solving the $2N+1$ equation simultaneously. The genetic parameters and the method of genetic operators used in optimization are shown in Table 1.

7. MENs Module for Minimum Freshwater Target

In this work, a MENs module is constructed to facilitate the freshwater minimization problem of any chemical process on Aspen Plus. The user simply selects the wastewater stream and contaminant and then inputs the limiting concentration of any unit operation, including the alternative for freshwater minimization, in the module. After that, the module obtains the optimum solution network of the process under the minimum freshwater target. The MENs module consists of Aspen Plus, Visual Basic, and MATLAB™. The schematic

Table 1. Genetic parameters and genetic operators

Genetic parameters/Operators	Value/Method
Population size	15
Probability of crossover, P_c	0.3
Probability of mutation, P_m	0.1
Crossover	Arithmetical crossover
Mutation	Transformation based mutation
Handling constraint strategy	CPSS
Selection	Selection

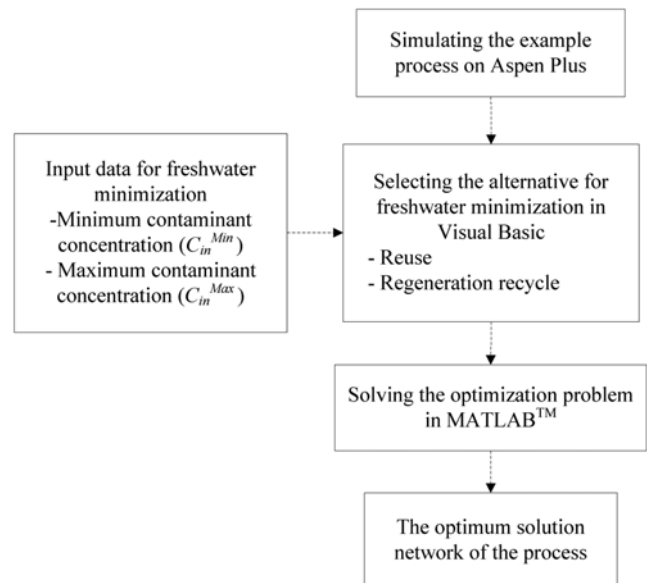

Fig. 2. Block diagram representation of the MENs module.

diagram of the module is shown in Fig. 2.

7-1. Process Modeling with Aspen Plus

The selected process would be as follows. First, construction and simulation on Aspen Plus. In the process, the source is any wastewater stream containing a contaminant, and the sink is any unit operation having a capability to receive contaminants. These sources and sinks have to be identified for mass-exchange networks (MENs) synthesis.

7-2. Input Data for Freshwater Minimization

The input data for freshwater minimization are the limiting concentration of each sink and the mass load of contaminants transferred to each sink. However, only the limiting concentration of each sink is required in the MENs module because the mass load of contaminants can be calculated by the MENs module automatically.

7-3. Formulation of Freshwater Minimization

After the input data for freshwater minimization are obtained completely, the alternatives - reuse or regeneration/recycling - to minimize the freshwater in the process can be selected in the MENs module. For the regeneration/recycling process, the outlet contaminant concentration of the regenerator ($C_{t,out}$) is considered in the MENs module as well.

7-4. Optimum Configuration

After the alternative for freshwater minimization is selected in Visual Basic, the data are sent to MATLAB™ in which a genetic algorithm is used to solve the optimization problem.

7-5. Optimum Solution Network of the Process

In the MENs module, an optimum water-using network of the process, which is a solution of the freshwater minimization problem, is obtained. The solution that is shown in MATLAB™ consists of the freshwater streams, the wastewater streams, and the reused water streams of each sink. Moreover, the inlet streams entering the regenerator and the outlet streams leaving the regenerator are also shown for the regeneration/recycling process.

8. Test of MENs Module

To ensure the accuracy and effectiveness of the algorithm of the

MENs module, the relevance of the MENs module is validated by chemical processes. In addition, the results from the module, such as reused streams and regeneration streams, are added to the example process on Aspen Plus to check mass balance around any unit operations and constraints.

PROBLEM STATEMENT

A mass-exchanger is defined as a direct-contact and counter-current unit that employs a mass-separating agent (MSA) to remove a certain constituent from a rich stream. The certain species generally represents a pollutant if it is discharged into the environment. At any rate, it may be a valuable raw material if it can be recovered for reuse within the plant. Examples of mass-exchangers are absorption columns, adsorbents, extraction units, strippers, and ion-exchange units.

Wastewater minimization can be conducted using three strategies: reuse, regeneration/reuse, and regeneration/recycling. This study is concerned with reuse and regeneration/recycling to investigate the most suitable approach to wastewater minimization. Mann and Liu addressed the water-using networks for a single-contaminant system by formulating and solving linear programming (LP). The solution of this optimization will provide the optimum water-using network for a minimum freshwater usage target.

1. Single-contaminant Water Reuse

The superstructure model of any water-using operation in a single-contaminant water reuse process is illustrated in Fig. 3.

The objective function, which is the minimum total freshwater flowrate, can be defined as in Eq. (10):

$$F_{min} = \sum_i F_i \tag{10}$$

where i is the number of unit operations ($i=1, 2, 3, \dots, n$ operations).

Then, the constraints governing the mass balance, maximum inlet contaminant concentration, maximum outlet contaminant concentration, and the fixed mass load of contaminant transferred in each operation are formulated. The water mass balance around each unit operation i in Fig. 3 is:

$$F_i + \sum_{j \neq i} X_{i,j} - W_i - \sum_{j \neq i} X_{j,i} = 0 \tag{11}$$

The formulation of the contaminant mass balance around each operation is shown as follows:

$$\sum_{j \neq i} C_{j,out} X_{i,j} + \Delta m_i - C_{i,out} \left(W_i + \sum_{j \neq i} X_{j,i} \right) = 0 \tag{12}$$

At the inlet, the average inlet concentration must be smaller than,

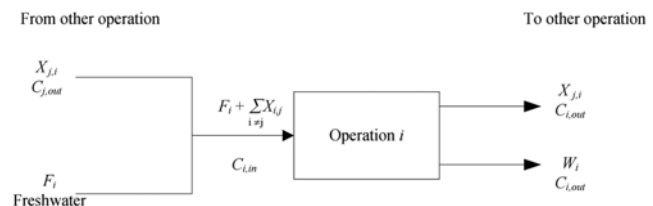

Fig. 3. Superstructure model of any operation of water reuse process.

or equal to, the maximum contaminant concentration $C_{i,in}^{max}$:

$$C_{i,in} = \frac{\sum_{j \neq i} X_{i,j} C_{j,out}}{\sum_{j \neq i} X_{i,j} + F_i} \leq C_{i,in}^{max} \tag{13}$$

For the fixed mass load of contaminant transferred, the outlet concentration is the sum of the average inlet concentration and the change in concentration. The outlet concentration must be equal to the maximum outlet contaminant concentration due to maximized water reuse. Hence, Eqs. (12) and (13) become Eqs. (14) and (15), respectively:

$$\sum_{j \neq i} C_{j,out}^{max} X_{i,j} + \Delta m_i - C_{i,out}^{max} \left(W_i + \sum_{j \neq i} X_{j,i} \right) = 0 \tag{14}$$

$$\frac{\sum_{j \neq i} X_{i,j} C_{j,out}^{max}}{\sum_{j \neq i} X_{i,j} + F_i} \leq C_{i,in}^{max} \tag{15}$$

Finally, a linear program is formulated. The objective is to minimize Eq. (10) with the constraints of Eqs. (11), (14) and (15).

2. Single-contaminant Regeneration/Recycling

The superstructure model of any water-using operation in a single-contaminant regeneration/recycling process is illustrated in Fig. 4. In this model the inlet stream includes freshwater, streams from other operations, and the stream from regeneration.

The superstructure model presented in the previous figure is used in a water balance around the regeneration process:

$$\sum_j X_{j,r} = \sum_j X_{r,j} \tag{16}$$

with j =number of unit operations from Eqs. (13), (14) and (15), which are modified to Eqs. (17), (18) and (19) in order to use a single-contaminant regeneration/recycling process:

$$F_i + \sum_{j \neq i} X_{i,j} + X_{i,r} - W_i - \sum_{j \neq i} X_{j,i} - X_{r,i} = 0 \tag{17}$$

$$\sum_{j \neq i} C_{j,out}^{max} X_{i,j} + C_o X_{i,r} + \Delta m_i - C_{i,out}^{max} \left(W_i + \sum_{j \neq i} X_{j,i} + X_{r,i} \right) = 0 \tag{18}$$

$$\frac{\sum_{j \neq i} X_{i,j} C_{j,out}^{max} + X_{i,r} C_o}{\sum_{j \neq i} X_{i,j} + F_i + X_{i,r}} \leq C_{i,in}^{max} \tag{19}$$

Then, Eq. (10) is minimized with the constraints of Eqs. (16) to (19).

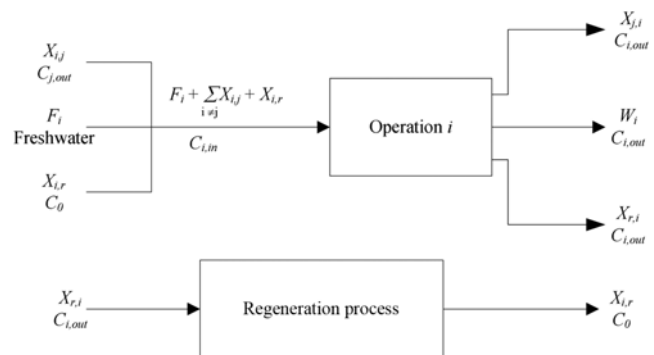

Fig. 4. Superstructure model of the regeneration/recycling process.

Finally, the optimization problem is solved by genetic algorithms.

3. Genetic Algorithms (GA)

For a single-contaminant water reuse system or a single-contaminant regeneration/recycling system that minimizes freshwater usage, the optimization is carried out using an improved GA.

RESULTS AND DISCUSSION

In this section, the results are divided into two parts: 1) process modeling by a mass exchange networks (MENS) module of Aspen Plus and 2) validation by case studies.

1. Mass-exchange Networks Module for Aspen Plus

The aim of constructing a mass-exchange networks (MENS) module for Aspen Plus is to supply information for the optimum network for the minimum freshwater usage target. This module consists of two parts. In the first part, a backup file of the process to be considered on Aspen Plus must be filled in the bank of the Aspen Plus file before clicking the start button, which will call on the Aspen Plus program to retrieve the supplemental data. The second part, consisting of two tabs, will next be considered.

2. Case Studies

Industrial process cases are utilized to test the MENS module. Process configurations, with reuse and with regeneration cycles, are analyzed in each case to determine the minimum freshwater usage. Furthermore, the effect of varying the regeneration concentration on the amount of freshwater consumed is discussed. The industrial case studied is a tricresyl phosphate ($(\text{CH}_3\text{C}_6\text{H}_4\text{O})_3\text{PO}$) process, as shown in Fig. 5, which is a flame retardant produced by the reaction of cresol ($\text{C}_7\text{H}_8\text{O}$) with phosphorus oxychloride (POCl_3). This flame retardant is commonly used in flexible PVC, cellulose nitrate, ethyl cellulose coatings, and in various rubbers. In this process, tricresyl phosphate is purified to remove the unreacted cresol. The process incorporates two washing units for product purification, two scrubbers, and a flare seal pot for removal of the contami-

Table 2. Concentration constraints

Unit operation	Mass load of contaminant (kg/s)	C_{in}^{max} (ppm)	C_{out}^{max} (ppm)
(1) Washing unit I	0.626	5	76
(2) Washing unit II	0.009	0	1
(3) Scrubber I	0.960	30	411
(4) Scrubber II	0.205	30	144
(5) Flare seal pot	0.130	100	281

Table 3. Flowrate and contaminant concentration of freshwater streams

Streams	Flowrate (kg/s)	Cresol concentration (ppm)	Cresol (kg/s)
FW ₁	2.45	0	0
FW ₂	2.45	0	0
FW ₃	0.7	0	0
FW ₄	0.5	0	0
FW ₅	0.2	0	0
Total	6.3	0	0

Table 4. Flowrate and contaminant concentration of wastewater streams

Streams	Flowrate (kg/s)	Cresol concentration (ppm)	Cresol (kg/s)
W ₁	2.45	71	1.74E-04
W ₂	2.45	1	2.45E-06
W ₃	0.7	381	2.67 E-04
W ₄	0.5	114	5.70 E-05
W ₅	0.2	181	3.62E-05
Total	6.3	85	5.36 E-04

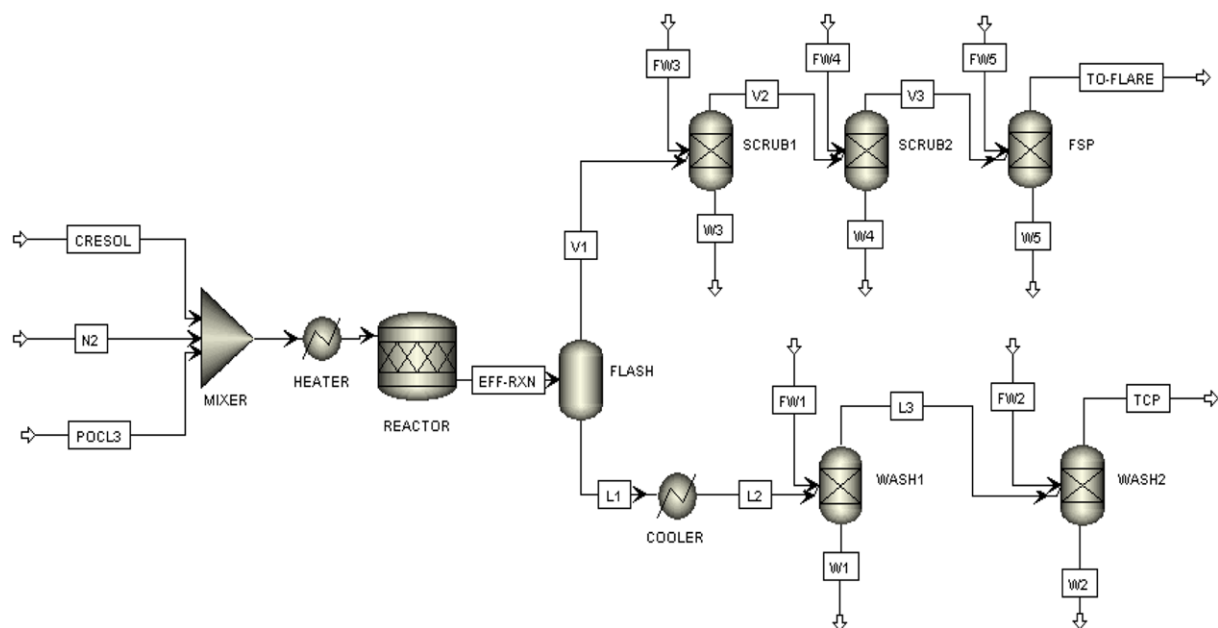

Fig. 5. Tricresyl phosphate process on Aspen Plus.

Table 5. Optimum result for the tricresyl phosphate process with reuse from the module

	Operation 1	Operation 2	Operation 3	Operation 4	Operation 5
Freshwater [ton/hr]	1.0627	10	0.00001	0	0
Wastewater [ton/hr]	6.2308	0	2.5197	1.5978	0.7146
Water reuse [ton/hr]		X12=7.3231 X21=0 X31=0.9743 X41=0.7086 X51=0.4721	X13=0 X23=0 X32=1.5453 X42=1.1316 X52=0	X14=0 X24=0 X34=0 X43=0 X53=0	X15=0 X25=0 X35=0 X45=0 X54=0.2424

nant from the off-gas. Consequently, there are five wastewater streams generated from these unit operations. The unit operations generating the wastewater streams are considered as sinks for mass-exchange network synthesis. The limiting inlet and outlet concentrations, and the mass load of contaminants permitted for each sink, are shown in Table 2.

Tables 3 and 4 show the flowrate and the cresol concentration of freshwater streams and wastewater streams, respectively.

3. Single-contaminant Water Reuse System

The freshwater consumption of the tricresyl phosphate process can be reduced through reuse. The result of water reuse from the MENs module is shown in Table 5.

The optimum network of the tricresyl phosphate process with reuse is shown in Fig. 6. The network shows only unit operations that are considered in the mass-exchange network.

As a result, the freshwater consumption of this process can be reduced from the base case: decreasing from 6.3 kg/s to 3.07 kg/s, or around 11.06 ton/hr, of freshwater consumption in the process. The optimized network with reuse results in 51% freshwater savings.

4. Single-contaminant Regeneration/Recycling System

In this process, light gas and oil, which are mass-separating agents

Table 6. Data for MSAs that can remove cresol from wastewater streams

Treatment type	$C_{t,out}^{min}$ (ppm)	Cost (\$/kg of cresol)
Oil	40	116
Light gas	3	434

(MSAs), are used to remove cresol from wastewater streams for regeneration. This provides minimum outlet concentrations ($C_{t,out}^{min}$) of cresol in the wastewater and cost for treatment of the candidate MSAs, as shown in Table 6, that are used in the same regeneration unit [2].

At the same regeneration unit or regenerator, oil treatment can remove cresol in wastewater streams to a minimum of 40 ppm, while light gas treatment can clean up to a minimum of 3 ppm.

For a regeneration/recycling system, the outlet concentrations for the water streams from the regenerator are maintained at the lowest possible values: 40 ppm for oil and 3 ppm for light gas. The results of oil treatment and light gas treatment obtained from the MENs module are shown in Tables 7 and 8, respectively.

These two figures indicate an optimized network with regenera-

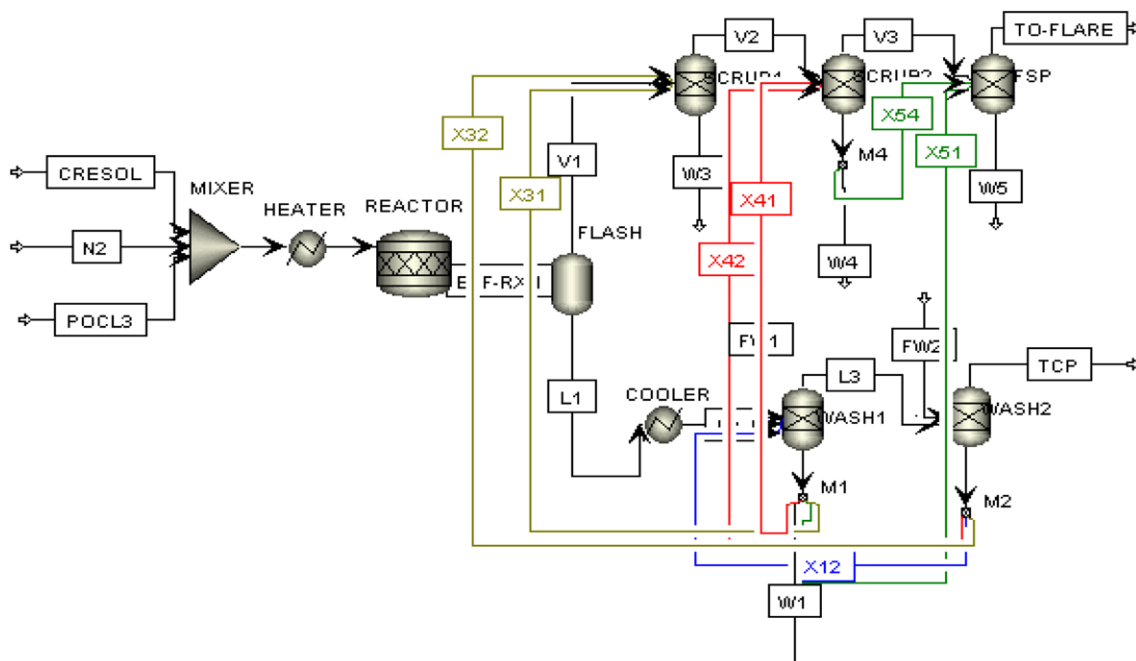

Fig. 6. Minimum freshwater-using network for the tricresyl phosphate process with reuse on Aspen Plus.

Table 7. Optimum result for the tricresyl phosphate process with regeneration/recycling using oil treatment obtained from the MENs module

	Operation 1	Operation 2	Operation 3	Operation 4	Operation 5
Freshwater [ton/hr]	0.4442	9	0	0.0797	0
Wastewater [ton/hr]	4.8697	0	2.5192	1.5425	0.5924
Water reuse [ton/hr]		X12=7.4571 X21=0 X31=0 X41=0 X51=0.2333	X13=0 X23=0 X32=0.9936 X42=0.3807 X52=0.1686	X14=0 X24=0 X34=0 X43=0 X53=0	X15=0 X25=0 X35=0.0555 X45=0 X54=0.2552
Regeneration [ton/hr]		X1R=0.9157 X2R=0 X3R=1.4701 X4R=1.3373 X5R=0		XR1=3.7139 XR2=0 XR3=0 XR4=0 XR5=0.0092	

Table 8. Optimum result for the tricresyl phosphate process with regeneration/recycling using light gas treatment obtained from the MENs module

	Operation 1	Operation 2	Operation 3	Operation 4	Operation 5
Freshwater [ton/hr]	0	9	0	0	0
Wastewater [ton/hr]	4.5922	0.7855	1.8074	1.2079	0.6069
Water reuse [ton/hr]		X12=8.1091 X21=0 X31=0 X41=0.2699 X51=0.6341	X13=0 X23=0 X32=0 X42=0.1054 X52=0	X14=0 X24=0 X34=0.3842 X43=0 X53=0	X15=0 X25=0 X35=0 X45=0 X54=0
Regeneration [ton/hr]		X1R=0.2441 X2R=0 X3R=2.1015 X4R=1.2169 X5R=0		XR1=2.8569 XR2=0 XR3=0.6783 XR4=0 XR5=0.0272	

tion/recycling using oil and light gas treatments as shown in Figs. 7 and 8, respectively. The figures only show the unit operations that are considered in the mass-exchange network, as seen in Table 9.

The results after applying the optimum information to Aspen Plus give the operational results at the same stage. For regeneration, oil treatment results in 58% freshwater savings, while light gas treatment results in 60% freshwater savings. Light gas for regeneration can save more freshwater than oil because light gas treatment cleans up cresol better than oil does. Therefore, the regenerated water from light gas treatment, with higher water quality, could be used in any sink more than once.

CONCLUSION

This work is to develop a mass-exchange networks (MENs) module for a minimum freshwater usage target. This module was developed as an interface to retrieve supplemental data of a chemical process from Aspen Plus and to communicate this to the genetic algorithm optimizer. In this work, a reuse system and a regeneration/recycling system with only a single contaminant are considered as approaches for freshwater minimization, and are formulated as mixed

integer nonlinear programming (MINLP). In this model, all variables are divided into two groups: independent and dependent variables. The values of independent variables come from randomization, whereas the values of dependent variables come from simultaneous solutions of a set of equality constraints after assigning the values of independent variables. This method is applied to the steps of initialization, crossover and mutation. The MENs module is tested with a tricresyl phosphate process that contains five unit operations in which water is used to remove a fixed content of cresol.

The module was constructed to develop a network of mass exchange for chemical processes, particularly wastewater processes. Wastewater is one of the major waste products of the chemical industry. When the amount of wastewater is large, wastewater treatment cost and freshwater cost are high. Moreover, when the amount of wastewater is large, the amount of contaminant may be large, resulting in a company losing a great deal of money if the contaminant cleanup cost is expensive. Therefore, the module was developed with a minimum freshwater usage target by considering water reuse and regeneration to achieve the optimum water usage network. This leads to a minimum of freshwater consumption, resulting in a minimum of consequently generated wastewater. Constructing this

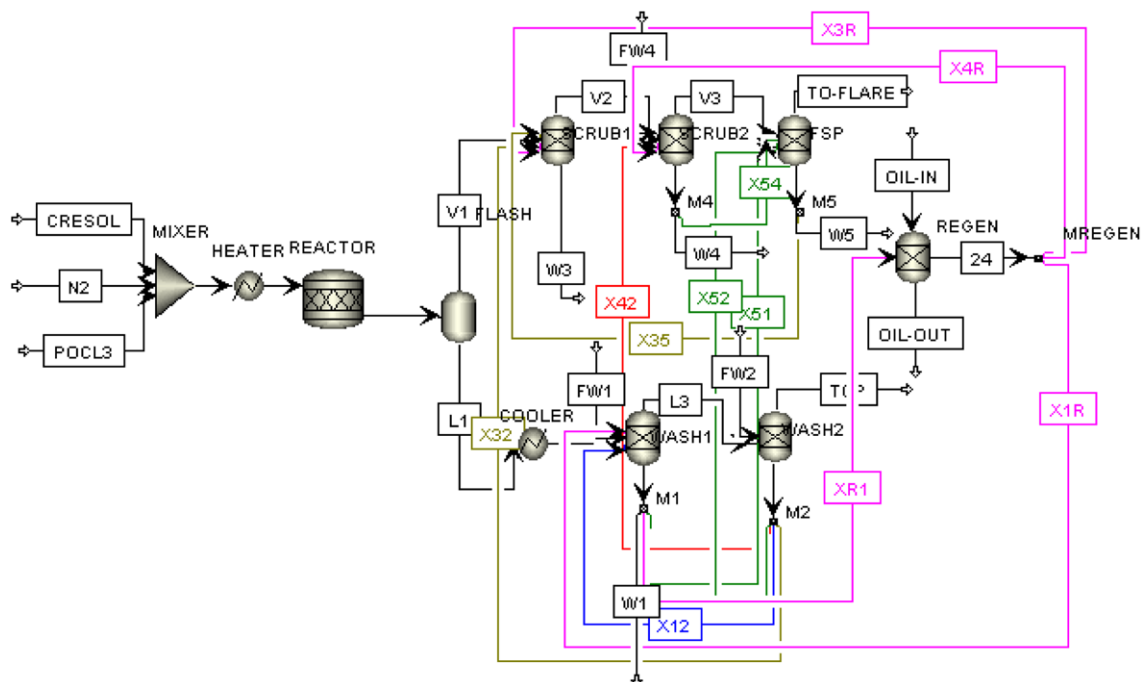

Fig. 7. Minimum freshwater-using network for the tricresyl phosphate process with regeneration/recycling using oil treatment on Aspen Plus.

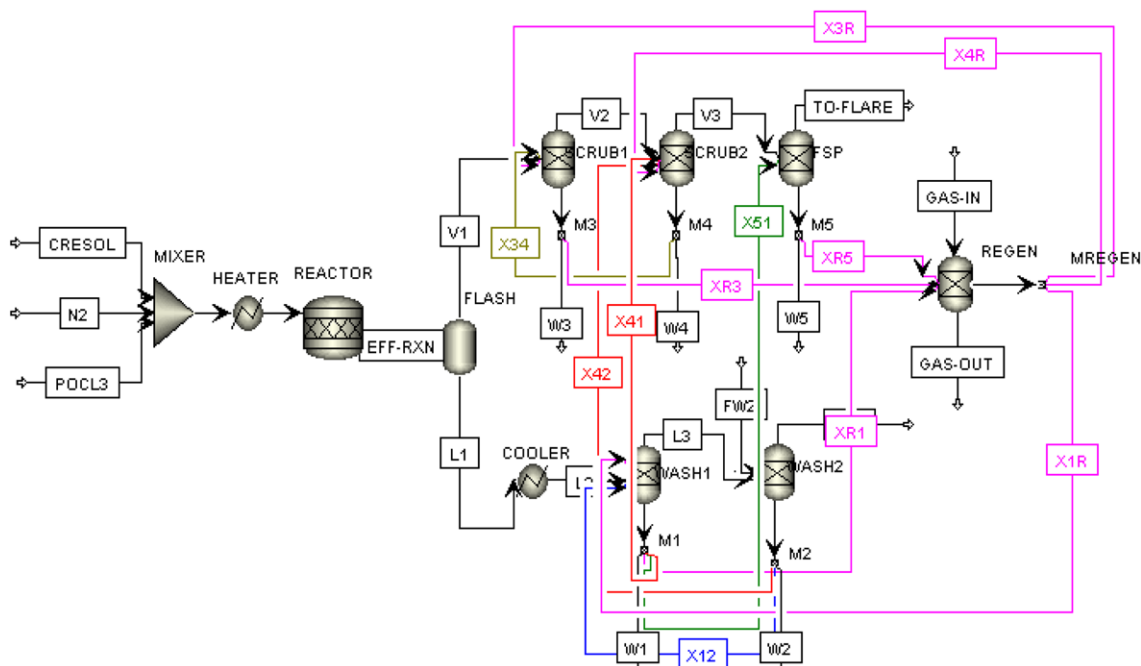

Fig. 8. Minimum freshwater-using network for the tricresyl phosphate process with regeneration/recycling using light gas treatment on Aspen Plus.

module possesses many advantages, as follows:

1. The module can be generalized for any chemical process.

Any chemical process on Aspen Plus can use the proposed module to find the optimum water usage network, leading to minimum freshwater consumption in the process. The module can be generalized for any chemical process. The module does not need to be modified by language or structure to suit a particular chemical process,

while conventional construction of the module with FORTRAN requires modifying the language, parameters and values to suit the specific process.

2. The module can decrease time consumption and provide a convenient method of calculating the input for freshwater minimization.

In the module, any streams in a chemical process on Aspen Plus can be selected for calculation to be used as input for freshwater

Table 9. Results for the tricresyl phosphate process with regeneration/recycling using oil and light gas on Aspen Plus

Streams	Oil			Light gas		
	Flowrate (kg/s)	Cresol concentration (ppm)	Cresol (kg/s)	Flowrate (kg/s)	Cresol concentration (ppm)	Cresol (kg/s)
W ₁	1.35	76	1.03 E-04	1.28	75	9.60E-05
W ₂	0	0	0	0.22	0.7	1.54E-07
W ₃	0.71	400	2.84 E-04	0.50	405	2.03E-04
W ₄	0.43	140	6.02E-05	0.33	145	4.79E-05
W ₅	0.15	344	5.16E-05	0.17	299	5.08E-05
Total	2.64	189	4.98 E-04	2.5	159	3.97E-04

minimization. When there are many wastewater streams, or when studying the conditions of unit operations in the processes that affect the flowrate and concentration of the streams, the module can retrieve the stream data from the chemical process for quick and convenient calculation. It also reduces the time required for calculating the input for freshwater minimization, in comparison to manual calculation.

3. The module gives a reliable solution for freshwater minimization

From testing the module with two chemical processes, the solution from the module can satisfy the mass balance and constraints. The results also agree with the theory that reuse and regeneration/recycling can reduce freshwater consumption, including wastewater generated but reuse cannot decrease the mass load of a contaminant, while regeneration/recycling can. Regeneration can conserve freshwater better than reuse, but a company must also consider investment cost. Moreover, if the cost of contaminant is expensive, regeneration is essential to consequently be used for recovery of the contaminant.

ACKNOWLEDGEMENTS

This project is supported by the National Center of Excellence for Petroleum, Petrochemicals and Advanced Materials, and Graduated School, Kasetsart University.

NOMENCLATURE

a : random value between 0 and 1
b : set of right-hand-side of inequality constraint
 F_i : flowrate of freshwater entering operation i [kg/s]
 W_i : flowrate of wastewater leaving operation i [kg/s]
 $X_{i,j}$: flowrate entering operation i from operation j [kg/s]
 $X_{i,r}$: flowrate entering operation i from regeneration [kg/s]
 $X_{r,i}$: flowrate entering regeneration from operation i [kg/s]
 C_0 : outlet concentration from regeneration [ppm]
 $C_{i,in}$: average inlet concentration entering operation i [ppm]
 $C_{i,out}$: outlet contaminant concentration of operation i [ppm]
 $C_{j,out}$: outlet contaminant concentration of operation j [ppm]
 $C_{i,in}^{max}$: maximum inlet contaminant concentration of operation i [ppm]
 $C_{i,out}^{max}$: maximum outlet contaminant concentration of operation i [ppm]
g(x) : set of left-hand-side of inequality constraint

S(x) : a function from the set of inequality constraints that returns the maximum value

P_c : crossover rate

P_m : mutation rate

P_s : selection rate

Greek Letters

α : shape factor of CPSS

Δm_i : total mass load of contaminant transferred from operation i [kg/hr]

REFERENCES

1. Y. P. Wang and R. Smith, Wastewater minimization, *Chem. Eng. Sci.*, **49**, 981 (1994).
2. M. M. El-Halwagi and V. Manousiouthakis, *Amer. Ins. Chem. Eng. J.*, **35**, 1233 (1989).
3. K. P. Papalexandri, E. N. Pistikopoulos and C. A. Floudas, *Chem. Eng. Res. Des.*, **72**, 279 (1994).
4. C. A. Floudas, *Nonlinear and mixed-integer optimization: fundamentals and applications*, Oxford University Press, New York, 460 (1995).
5. T. F. Yee and I. E. Grossmann, Simultaneous optimization models for heat integration - II. Heat exchanger network synthesis, *Comput. Chem. Eng.*, **14**, 1165 (1990).
6. A. Garrard and E. S. Fraga, *Comput. Chem. Eng.*, **22**, 12 (1998).
7. U. Suriyapraphadilok, *Network prototype of water-wastewater management*, Master's thesis, Chemical Engineering Practice School, King Mongkut's University of Technology Thonburi, 113 (1998).
8. T. Krirkkrajiporn, *Multi-component optimization of simultaneous heat and mass exchanger networks using GAMS*, Master's thesis, Chemical Engineering Program, Kasetsart University, 221 (2002).
9. GAMS Development Corporation, <http://www.gams.com/solvers/index.html>.
10. D. Prakotpol and T. Srinophakun, *Chem. Eng. Process.*, **43**, 203 (2004).
11. Lingo Systems, <http://www.lingo.com>.
12. T. Wasanapradit, *Solving nonlinear mixed integer programming using genetic algorithms*, Master's thesis, Chemical Engineering Practice School, King Mongkut's University of Technology Thonburi, 90 (2000).