

Simultaneous optimal integration of water utilization and heat exchange networks using holistic mathematical programming

Wu Xiao*, Rui-jie Zhou***, Hong-Guang Dong*[†], Nan Meng*, Chih-Yao Lin**,
 and Vincentius Surya Kurnia Adi**

*School of Chemical Engineering, Dalian University of Technology, Dalian 116012, Liao Ning, PRC
 **Department of Chemical Engineering, National Cheng Kung University, Tainan 70101, Taiwan, ROC
 ***Department of Economics, Dalian University of Technology, Dalian 116024, Liao Ning, PRC
 (Received 2 March 2008 • accepted 1 February 2009)

Abstract—A systematic holistic mathematical programming (HMP) is proposed to formulate a mixed integer non-linear programming (MINLP) model for one-step optimization of water-allocation and heat exchange network (WAHEN) designs with single- or multi-contaminant water streams. The proposed model formulation and solution strategy are believed to be superior to the available ones in the following aspects. First, a comprehensive representation combining two separate superstructures is adopted to capture the structural characteristics of the integrated WAHEN. Then, a hybrid optimization strategy integrating stochastic and deterministic components is developed for the resulting MINLP model and, also, an interactive iteration method is adopted based on sensitivity analysis to guide the search toward a potential global optimum. Finally, evolutionary strategies and manipulations are executed to enhance WAHEN configurations. Two illustrative examples are presented to demonstrate the validity and advantages of the proposed approach.

Key words: Simultaneous Optimization, Water Utilization Network, Heat Exchange Network, Evolutionary Strategy

INTRODUCTION

Resource shortage crisis and environment pollution pressure will be the major factors that restrict sustainable development in this century. Now that all kinds of water and energy unit operations widely exist in the process industries, the problem of effective water reuse and heat recovery has become a topic which is drawing greater attention. Fresh water and fossil energy shortage and rivers and seas pollution require that effective measures must be taken that can save energy and water, as well as reduce utility consumption and waste discharge to ease the contradiction.

In most of the petrochemical industry production united plants, water works as not only the separation solvent for removing contaminants in the process streams, but also the utility carrier in heat exchange process. Fresh water becomes waste water after water utilization unit operations, while hot and cold utility (cooling water and heating steam) is restored through the power cycle. For water utilization and heat exchange which involve both mass and heat transfers, the contaminant concentration limit plays a decisive role in process water reuse level, and the utility usage is determined by water temperature or steam pressure; therefore, the transfer process effect of water utilization and heat exchange is interactively influenced by concentration and temperature.

WU-HENs simultaneous synthesis belongs to the process integration field, and heat exchange and water utilization processes are both typical representations of energy and mass integration, respectively. Pinch technology based on thermodynamics objective is successfully implemented in industrial practice and theoretical study

of WUN and HEN, respectively [1-3]. However, as to the comprehensive global economic optimization indicators pursued by all researchers in process synthesis and integration fields, mathematical programming based on superstructures is always an important strategy to solve the problem perfectly [4]. In the literature [5-8], the problem of HENs synthesis is studied by using mathematical programming methods. [9-12], have also studied the problem of WUNs synthesis by mathematical programming methods. In fact, for a long time, the synthesis problems of HEN or WUN were considered separately, until Savulescu and Smith [13] studied the problem of simultaneous energy and water utilization minimization. Bagajewicz et al. [14] then further explored this aspect.

Savulescu and Smith [13] and Savulescu et al. [15,16] proposed a conceptual design method, i.e., the water-energy pinch analysis, to solve the combined WAN-HEN optimization problem. The so-called *separate system approach* was adopted to create the overall network design with a graphic tool—the two-dimensional grid diagram. Although both direct and indirect heat-exchange options have been considered in their work [17], it is still very difficult to incorporate all possible network configurations and to identify an optimal solution with the minimum total annualized cost (TAC) using this heuristic approach. On the other hand, Bagajewicz et al. [14] tried to solve the same problem with mathematical programming models. They developed a series of transshipment formulations on the basis of the optimality conditions for water-using networks [18]. In these models, the process-to-process connection streams were allowed to be heated/cooled with heat exchangers. However, since the original nonlinear functions in NLP and MINLP models were linearized, the true optimal design may not be identifiable by using this method. Notice also that the aforementioned two approaches are really not applicable to the multi-contaminant problems that are

[†]To whom correspondence should be addressed.
 E-mail: hgdong@dlut.edu.cn

usually encountered in the process industries and, more importantly, both are in essence sequential procedures. Their common main drawback is that the trade-offs between capital investments and operating costs, i.e., those associated with freshwater and heating and cooling utilities, cannot be properly balanced. Therefore, there is a need to develop a more comprehensive design method for optimizing the integrated water allocation and heat-exchange networks (WAHENS).

To illustrate the WAHEN design method developed in this work, the rest of this paper is organized as follows. The WAHEN design problem is formally defined in the next section. As mentioned previously in the abstract, a comprehensive representation [6,19] is adopted in the present study to construct a superstructure for capturing the unique characteristics of generalized WAHEN configuration. This comprehensive representation and the corresponding MINLP model are described in Section 3. A hybrid optimization strategy has also been developed to solve the proposed model and an outline of the solution algorithm can be found in the following section. Two examples are then presented in Section 5 to demonstrate the feasibility and effectiveness of the proposed solution method. The capabilities of our model can also be clearly observed from the resulting network designs. Finally, the conclusions of this research and some comments on future work are provided in the last section.

PROBLEM DESCRIPTION

A general WAHEN design problem can be stated as follows: Given a set of freshwater sources, a set of wastewater sinks, a set of hot and cold utilities and a set of existing water-using units, it is desired to synthesize a cost-optimal WAHEN that can fulfill the mass-load requirements of all water-using units and also satisfy the concentration, temperature and flow-rate constraints imposed at various locations in the network.

To facilitate a concise formulation of the mathematical model, the following simplification assumptions are introduced in this study:

- Each unit is operated isothermally without water loss and heat loss;
- Only water reusing is considered, while waste water treatment and water regeneration are excluded;
- The concentration of contaminant is assumed to be at a very low level, and water flow rate is assumed to be constant;
- The mass load of contaminant transfer does not change;
- The temperatures of fresh water supply and waste water discharge have been given;
- Only indirect heat exchange opportunities are taken into account. Direct heat exchange is not considered for the sake of simplicity.

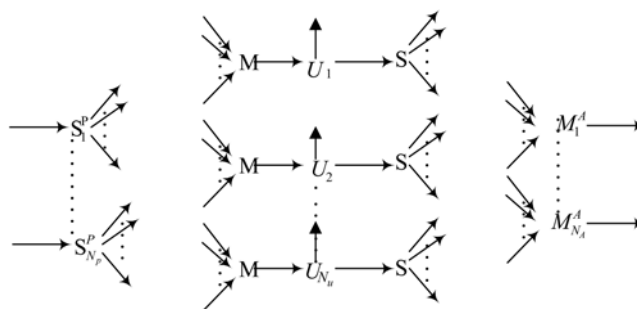

Fig. 1. Superstructure of a water utilization network (WUN).

WU-HENS SUPERSTRUCTURE MATHEMATICAL MODEL

1. WUN Superstructure Modeling

Similar to other optimization study in process synthesis, it is necessary to first build a superstructure in which all possible flow configurations can be embedded. Our superstructure for WUN is essentially the same as that suggested by Papalexaddri and Pistikopoulos [19]. A simple construction procedure of the superstructure is presented below:

- (1) Place a mixing node at the inlet of every buffer tank and every sink.
- (2) Place a splitting node at outlet of every source and every buffer tank.
- (3) Connect the split branches from each source to all mixing nodes.
- (4) Connect the split branches from each buffer tank to all mixing nodes except the one before the same tank.

This flow connection scheme is presented in Fig. 1, and superstructure of any water utilization process unit is shown in Fig. 2. This superstructure is solved by mathematical programming; the flow rates of fresh water streams to their targeting units and water streams flow rates between units as well as units waste water discharge flow rates can be obtained; thus the optimal WUN structure is achieved [11].

Only if the process water is reused to its greatest degree, can fresh water consumption or waste water discharge be minimized. For water utilization operation general unit i , and for any contaminant k in water streams, the mass transfer load of a fixed contaminant is defined as $\Delta m_{i,k,out}$, inlet maximum allowed contaminant concentration limit is $C_{i,k,in}^{max}$, outlet maximum allowed contaminant concentration limit is $C_{i,k,out}^{max}$, flow rate of fresh water supplied is f_i , flow rate of waste water discharged is W_i , and the related contaminant

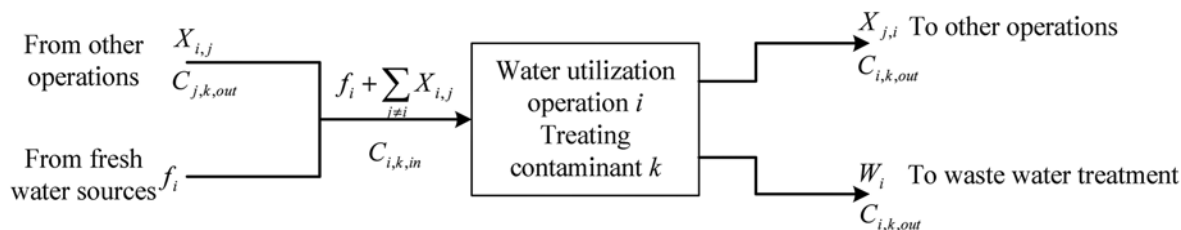

Fig. 2. Superstructure model of a general water utilizing operation.

concentration is $C_{i,k,out}$. For another water utilization operation general unit j , $X_{i,j}$ is flow rate of the reused process water from j to i , and the related contaminant concentration is $C_{j,k,out}$. If the interaction of solubility among different contaminants is not considered, the multi contaminant water utilization problem can be translated to a problem of single contaminant with multiple restrictions. The mathematical model with minimum fresh water flow rate of water utilization operations is shown as follows:

WUN synthesis objective function:

$$\min C_{fw} \sum_{i=1}^N f_i \tag{1}$$

where is the unit prices coefficient of the fresh water.

WUN synthesis constraints:

The mass transfer driving force is acquired by maximum inlet and outlet concentration limits within water utilization operations, while mass balance restrictions are obtained from the fixed contaminant mass transfer load.

The inlet concentration is calculated by weighted average approach of flow rates,

$$C_{i,k,in} = \frac{\sum_{j \neq i} X_{i,j} C_{j,k,out}}{\sum_{j \neq i} X_{i,j} + f_i} \leq C_{i,k,in}^{max} \tag{2}$$

The outlet concentrations is calculated in terms of the fixed contaminant mass transfer load,

$$C_{i,k,out} = C_{i,k,in} + \frac{\Delta m_{i,k,out}}{\sum_{j \neq i} X_{i,j} + f_i} = C_{i,k,out}^{max} \tag{3}$$

Eqs. (2) and (3) are combined into a linear analogous form.

$$\sum_{j \neq i} (C_{i,k,in}^{max} - C_{j,k,out}) X_{i,j} + C_{i,k,in}^{max} f_i \geq 0 \tag{4}$$

$$\sum_{j \neq i} (C_{i,k,out}^{max} - C_{j,k,out}) X_{i,j} + C_{i,k,out}^{max} f_i = \Delta m_{i,k,out} \tag{5}$$

The total mass balance of water utilization operation units is shown as follows,

$$f_i + \sum_{j \neq i} X_{i,j} - W_i - \sum_{i \neq j} X_{j,i} = 0 \tag{6}$$

The following are the nonnegative restrictions of process variables,

$$f_i \geq 0, W_i \geq 0 \tag{7}$$

$$X_{i,j} \geq 0, C_{j,k,out} \geq 0 \tag{8}$$

The NLP mathematical model of multi contaminant WUN is constructed by Eqs. (1) and (4)-(8). If the necessary conditions of the optimal concentration monotonicity of WUN can be satisfied [18], which means $C_{i,k,out} = C_{i,k,out}^{max} = \text{constant}$, the NLP mathematical model can be regressed to an LP.

In the superstructure mathematical model of WUN above, because the number of water utilization operation units is given in advance, fresh water distribution, process water reuse, waste water discharge and other water consumptions within all kinds of match processes, as well as the outlet contaminant concentration indicators of water utilization units are all the optimized decision variables. For the contaminant k in the stream between water utilization operation units i and j , any water utilization match in the model can be represented as $(f_i, X_{i,j}, C_{j,k,out}, W_i, X_{j,i}, C_{i,k,out})$, where f_i is the fresh water flow rate of the match, $X_{i,j}, X_{j,i}$ are process reuse water flow rates, W_i is waste water flow rate and $C_{j,k,out}, C_{i,k,out}$ are outlet concentrations. Therefore, for the WUN synthesis problem of a system involving M contaminants and N water utilization units, the number of continuous variables needed to be optimized in its superstructure is $N \times N \times (N - 1) \times N \times M$.

2. HEN Superstructure Modeling

The HEN synthesis problem can be defined as follows: A set of hot process streams, $NH = \{i | i = 0, 1, \dots, N_H - 1\}$, are to be cooled and a set of cold process streams, $NC = \{j | j = 0, 1, \dots, N_C - 1\}$, are to

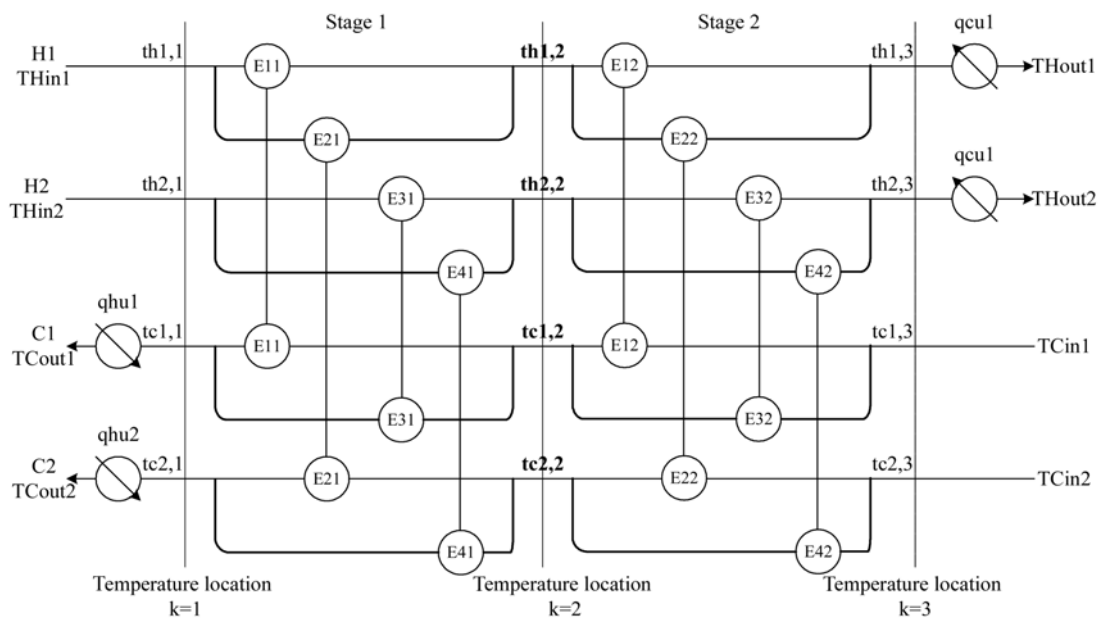

Fig. 3. Two-stage superstructure model of heat exchanger network.

be heated. Initial temperatures T_{in} and target temperatures T_{out} are given. Heat capacity flow rates f and heat transfer film coefficients of stream k are also specified. A set of hot utilities, HU, and a set of cold utilities, CU, and their corresponding temperatures as well as their relevant cost data are also given. Cost data are given for possible heat transfer equipment, including fixed and area-dependent cost factors that may also include piping and installation costs. Then the objective is to determine the HEN configuration that minimizes the annual cost. And utility loads, heat exchange areas, the number of units, heat loads and operation temperatures of every heat exchanger, stream matches and flow rates of every branch stream are all included.

The superstructure mathematical model of HEN can be formulated as an MINLP problem; moreover, it does not depend on the pinch technology, so simultaneous optimization of all the economic indicators of HEN can be achieved. The superstructure is a stage-wise representation of a structure embedded with all possible matches between any two streams within a stage. And in the superstructure the number of stages is $N_k = \max\{N_H, N_C\}$. Only one match is defined for the same hot and cold stream pair in a stage, hence in each stage the maximum allowable number of heat exchangers is $N_H \times N_C$. The heaters and coolers are outside the superstructure stages for simplification. Fig. 3 shows an illustration of the superstructure for a synthesis problem with two hot streams and two cold streams.

To formulate the mathematical model of HEN for the proposed superstructure described previously, the following definitions are necessary. $q_{cu,i}$ is cold utility load of every hot stream i , and $q_{hu,j}$ is the hot utility load of every cold stream j . Outlet temperatures of the splits of every hot process stream i and cold stream j of a match in the stage k matching heat exchange are represented as $th_{i,j,k}$ and $tc_{i,j,k}$ respectively, the related heat capacity flow rates are $fh_{i,j,k}$ and $fc_{i,j,k}$ and the heat load of heat exchange matches is $q_{i,j,k}$. $th_{i,k}$ represents inlet temperature of hot stream i in k stage, while $tc_{j,k}$ represents outlet temperature of cold stream j in k stage after whose splits are all mixed together. TH_{in} and TC_{in} are initial temperatures of hot and cold streams, TH_{out} and TC_{out} are objective temperatures of hot and cold streams, respectively. Therefore, superstructure mathematical model of HENs can be established as follows:

HEN synthesis subject to:

(1) Overall heat balance of each stream

$$\begin{aligned} (TH_{in,i} - TH_{out,i}) \cdot fh_i &= \sum_k \sum_j q_{i,j,k} + q_{cu,i}, i \in NH \\ (TC_{out,i} - TC_{in,i}) \cdot fc_j &= \sum_k \sum_i q_{i,j,k} + q_{hu,j}, j \in NC \end{aligned} \quad (9)$$

(2) Heat balance of every heat exchanger

$$\begin{aligned} (th_{i,k} - th_{i,j,k}) \cdot fh_{i,j,k} &= q_{i,j,k} \\ (tc_{i,j,k} - tc_{j,k+1}) \cdot fc_{i,j,k} &= q_{i,j,k} \quad i \in NH, j \in NC, k \in NK \end{aligned} \quad (10)$$

(3) Mass and heat balance at stage k

For each hot stream:

$$\sum_j fh_{i,j,k} = fh_i, \quad \sum_j th_{i,j,k} \cdot fh_{i,j,k} = th_{i,k+1} \cdot fh_i, \quad i \in NH, k \in NK \quad (11)$$

For each cold stream:

$$\sum_i fc_{i,j,k} = fc_j, \quad \sum_i tc_{i,j,k} \cdot fc_{i,j,k} = tc_{j,k} \cdot fc_j, \quad j \in NC, k \in NK \quad (12)$$

(4) Assignment of superstructure inlet temperature

$$TH_{in,i} = th_{i,0}, \quad i \in NH; \quad TC_{in,j} = tc_{j,N_k}, \quad j \in NC \quad (13)$$

(5) Feasibility of temperatures

$$\begin{aligned} th_{i,k} \geq th_{i,j,k}, \quad tc_{j,k+1} \leq tc_{i,j,k}, \quad TH_{out,i} \leq th_{i,N_k}, \quad TC_{out,j} \geq tc_{j,0} \\ i \in NH, j \in NC, k \in NK \end{aligned} \quad (14)$$

(6) Cold and hot utilities loads

$$\begin{aligned} (th_{i,N_k} - T_{out,i}) \cdot fh_i &= q_{cu,i}, \quad i \in NH; \\ (TC_{out,j} - tc_{j,0}) \cdot fc_j &= q_{hu,j}, \quad j \in NC \end{aligned} \quad (15)$$

(7) Minimum approach temperature constraints

For each heat exchanger:

$$\begin{aligned} th_{i,k} - tc_{i,j,k} \geq \Delta t_{min}, \quad th_{i,j,k} - tc_{j,k+1} \geq \Delta t_{min}, \\ i \in NH, j \in NC, k \in NK \end{aligned} \quad (16)$$

For hot utility:

$$t_{hu,j,in} - TC_{out,j} \geq \Delta t_{min}, \quad t_{hu,j,out} - tc_{j,0} \geq \Delta t_{min}, \quad j \in NC \quad (17)$$

Where $t_{hu,j,in}$ and $t_{hu,j,out}$ are inlet and outlet temperatures of hot utility matching with cold stream j , respectively.

For cold utility:

$$th_{i,N_k} - t_{cu,i,out} \geq \Delta t_{min}, \quad TH_{out,i} - t_{cu,i,in} \geq \Delta t_{min}, \quad i \in NH \quad (18)$$

Where $t_{cu,i,in}$ and $t_{cu,i,out}$ are inlet and outlet temperatures of cold utility matching with hot stream i , respectively.

(8) Other constraints

The continuous variables ($th_{i,j,k}, tc_{i,j,k}, fh_{i,j,k}, fc_{i,j,k}, q_{i,j,k}, th_{i,k}, tc_{j,k}, q_{cu,i}, q_{hu,j}$) should be nonnegative.

$$(th_{i,j,k}, tc_{i,j,k}, fh_{i,j,k}, fc_{i,j,k}, q_{i,j,k}, th_{i,k}, tc_{j,k}, q_{cu,i}, q_{hu,j}) \geq 0 \quad (19)$$

The binary variables ($y_{i,j,k}, y_{cu,i}, y_{hu,j}$) denote the existence of exchangers, coolers and heaters.

$$(y_{i,j,k}, y_{cu,i}, y_{hu,j}) \in (0, 1) \quad (20)$$

Objective function of HEN synthesis:

To simultaneously optimize HEN, the objective function is written as total annual cost, which includes utilities cost, fixed capital cost and area cost of heat exchangers. The cost equation of heat exchange equipments (including heat exchangers, coolers and heaters) is $Cf + C \cdot A^B$, where the first item Cf is fixed cost of heat exchanger, the second one is area cost of heat exchanger, and C , A and B are area cost coefficient, heat transfer area and exponent for area cost, respectively. The objective function of simultaneous synthesis is presented as follows.

$$\begin{aligned} \min \sum_i C_{cu} \cdot q_{cu,i} + \sum_j C_{hu} \cdot q_{hu,j} + \sum_i \sum_j \sum_k Cf_{i,j,k} \cdot y_{i,j,k} + \sum_i Cf_{cu,i} \cdot y_{cu,i} \\ + \sum_j Cf_{hu,j} \cdot y_{hu,j} + \sum_i \sum_j \sum_k C_{i,j,k} \cdot A_{i,j,k}^B \cdot y_{i,j,k} \\ + \sum_i C_{cu,i} \cdot A_{cu,i}^B \cdot y_{cu,i} + \sum_j C_{hu,j} \cdot A_{hu,j}^B \cdot y_{hu,j} \end{aligned} \quad (21)$$

Where c_{cu} and c_{hu} are per unit costs for cold and hot utilities, respectively. The area of any match (i, j, k) (including heaters and coolers) can be calculated according to Eq. (22).

$$A_{i,j,k} = q_{i,j,k} / (K_g \cdot \text{LMTD}_{i,j,k}) \quad (22)$$

K_g is the overall heat transfer coefficient of the match in between

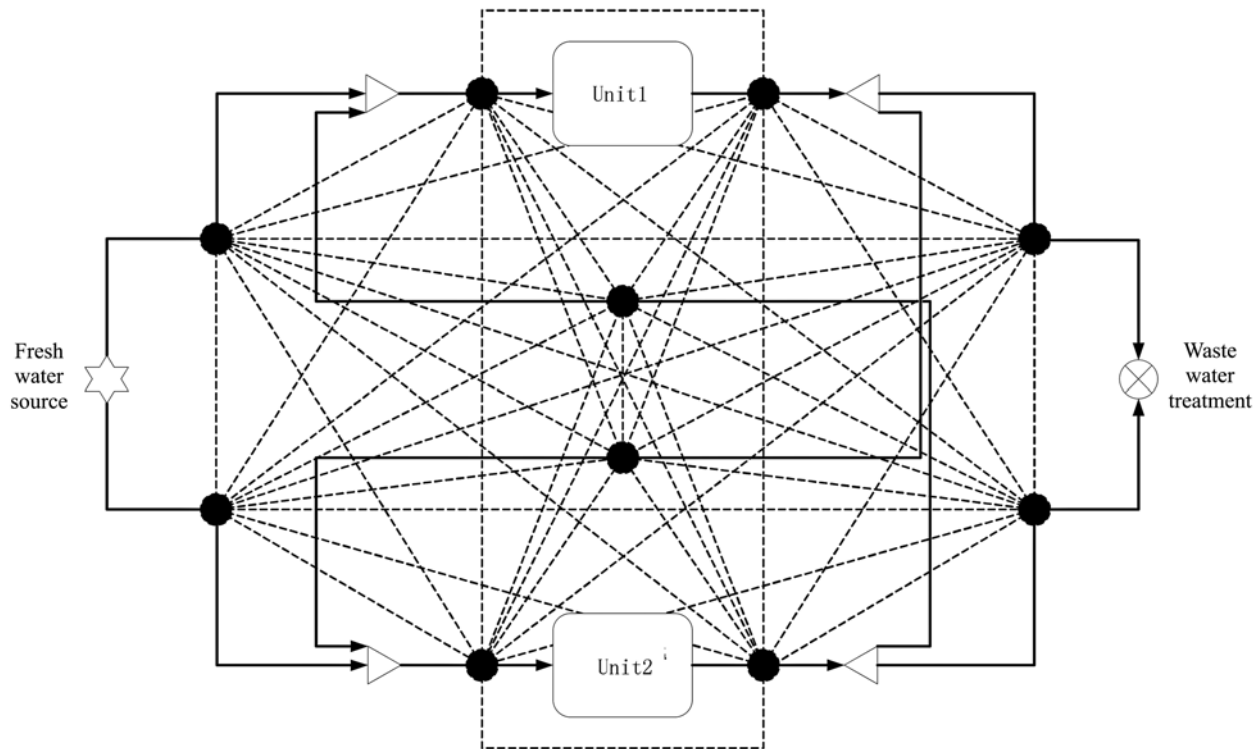

Fig. 4. Topology structure of water network with heat integration (split/mix).

hot stream i and cold stream j , which formulation is as follows.

$$K_{i,j} = k_i k_j / (k_i + k_j) \tag{23}$$

LMTD is the logarithmic mean difference temperature of match streams, which formulation is as follows.

$$LMTD_{i,j} = \frac{dt_{i,j,k-1} - dt_{i,j,k}}{\ln \frac{dt_{i,j,k-1}}{dt_{i,j,k}}} \tag{24}$$

The MINLP mathematical model of HEN is composed of Eqs. (9)-(20) and (21) [6,7].

Within the superstructure mathematical model of HEN above, the optimized variables include streams matches order, heat load of every exchanger and structure parameters of HEN. For each match at any stage of the model, for example, the match of hot stream i and cold stream j at stage k is represented as $(fh_{i,j,k}, fc_{i,j,k}, q_{i,j,k})$, where $fh_{i,j,k}$, $fc_{i,j,k}$, $q_{i,j,k}$ are heat capacity flow rates of hot and cold streams and heat load of this match, respectively. Therefore, for a heat exchange problem including N_H hot streams and N_C cold streams, the possible number of heat exchangers involved in its superstructure is $N_H \times N_C \times N_K$, the number of optimized continuous variables is $3 \times N_H \times N_C \times H_K$, and the number of optimized binary parameters by the HEN structure is $N_H \times N_C \times H_K$.

HMP SIMULTANEOUS SOLUTION STRATEGY FOR WU-HENS

The main idea of the sequential calculation method is the following: Minimum fresh water consumption and WUN structure, minimum utility consumption and HEN structure are determined in turn,

and finally WU-HENS is obtained by integration. The main idea of the simultaneous calculation method follows: Tradeoff in between minimum fresh water consumption and minimum utility consumption is achieved, and WUN structure is coordinated with HEN structure, then finally WU-HENS is attained by programming.

1. Structure Topology and Variable Connection

The streams connections between fresh water sources, water utilization units and waste water sinks are arranged by WUN synthesis, while the matches between cold and hot streams are arranged by HEN synthesis. To achieve simultaneous and holistic mathematical programming, between the two sub-problems, complete correlation topologies of process flows and transfer of related variables among connection equations need to be developed.

In terms of typical definition of the problem forming, fresh water, reused process water and waste water all can join in heat exchangers. Therefore, graph theory can be used to illustrate the connection characteristic of flow topology. The simplest energy integration network involving two water utilization operating units is shown in Fig. 4. The whole graph is a direction graph consisting of three parts, in which the sub-graphs are described as follows: The fresh water supply lines to water utilization operations are all connected, and a complete radiation-tree connection graph from fresh water sources to all the water utilization units is constructed. The process water reuse lines shuttling between water utilization operating units are all connected, and a complete strongly-connected graph of network covering all the water utilization units is drawn. The waste water discharge lines from water utilization operation units are all connected, and a complete focus-tree connection graph from all the water utilization units to waste water sinks is formed. A total stream set is set up by connecting the nodes on the complete graph, also cold and

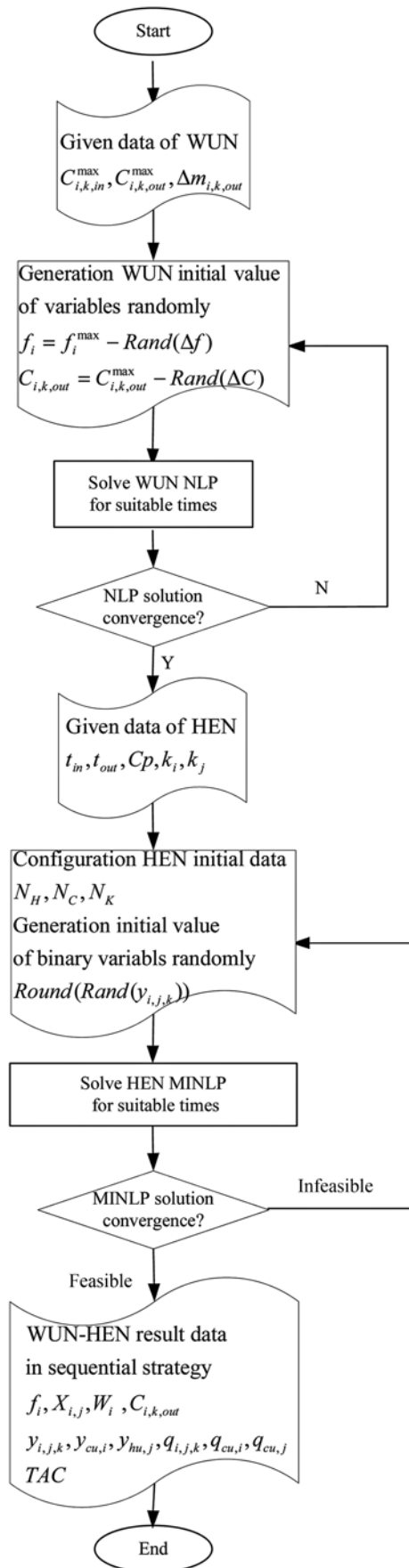

Fig. 5. The flowchart of sequential algorithm solution procedure.

hot heat exchange streams sets are divided. The possibility of matching heat exchange exists between any two streams, which means that a complete network strongly-connected graph can be established by connecting all the potential heat exchange nodes of streams.

Two sub-systems are included in WU-HENs system: WUN sub-system and HEN sub-system. The structures of the two sub-systems are coupled and connected. The contaminant transfer mass loads are accomplished by specific water utilization operating units of WUN synthesis including fresh water supply, process water reuse, waste water discharge and other water utilization matches. Furthermore, through the matching heat exchange in between hot and cold streams by HEN synthesis, the temperature changes of cold and hot streams are achieved from the initial value to the objective temperature. Simultaneous optimization of sub-systems is required by integration of the whole WU-HENs system, and the synthesis problems of WUN and HEN sub-systems are defined accompanying each other to form complex symbiotic synthesis problems.

The sequential and simultaneous strategies use the same process relation, and both of the two methods need mass balance, energy 1 the sequential and simultaneous strategies lies in the extraction form for process information; the difference in the connection equations between WUN and HEN is their specific performance. Within the sequential strategy, firstly according to the given initial conditions, objective functions and related constraints of WUN are satisfied to solve the design problems of WUN, and then taking the design results of WUN as prerequisites, HEN objective function and related constraints are satisfied to solve the design problems of HEN. Interactive cycle does not appear in the design processes of the two sub-problems; according to the dynamic programming optimization principle, the final result of the serial design is only a non-inferior solution, while global optimization is not guaranteed. Within the simultaneous strategy, according to the given initial conditions of the whole problem, all the process relation information is overall considered and parallel processed. First, the objective function is unified; no matter WUN or HEN, the objective functions can be unified to economic indicators, including equipment cost and operation cost, which is the result of adding Eq. (1) to (21) simply. Moreover, constraint conformity should be guaranteed, so the constraints of WUN and HEN are satisfied simultaneously, which means equations from (2) to (19) are combined. Finally, simultaneous integration of WUN and HEN is achieved by HMP. Because the optimization problem is considered in the round by the simultaneous strategy, the global optimal solution can be obtained in theory.

All equations of the water utilization and heat exchange processes are set up according to the logic relation between the two sub-problems of WU-HENs. First, cold and hot streams sets of HEN are divided by water utilization streams sets of WUN. And then, related stream flow rates are regarded as variables to be transferred simultaneously. The set division must include all the process streams, and every water utilization stream of WUN must be cold or hot stream of HEN. The detail processes of establishing the simultaneous equations are as follows:

Connection of streams sets between WUN and HEN:
 $F \cup X \cup W = N_H \cup N_C$

Connection of variable equations between WUN and HEN:
 $\forall i \in F \cup X \cup W, \exists h \in N_H, f_i = f_h$

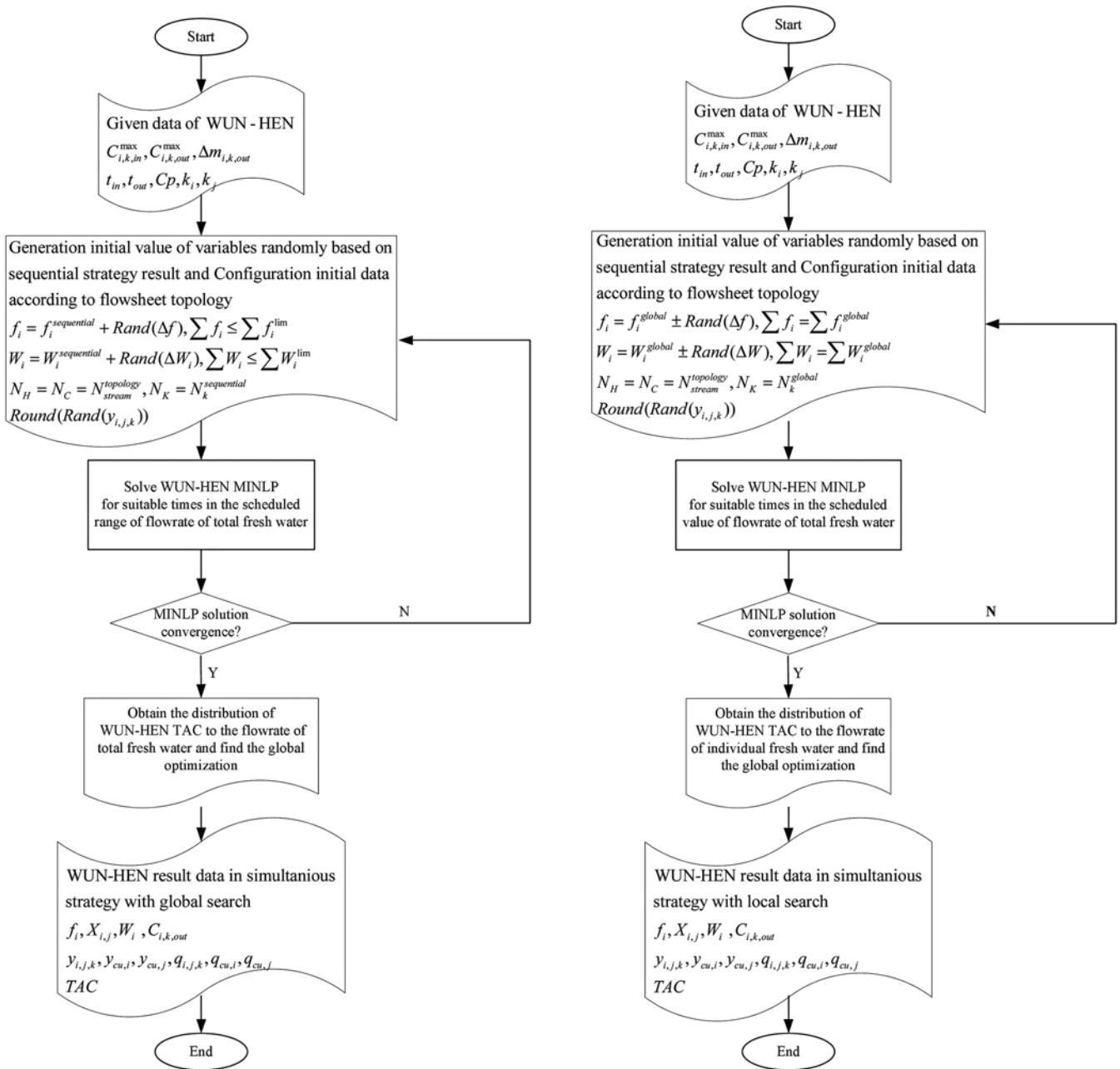

Fig. 6. The flowchart of global and local search simultaneous algorithm solution procedure.

$$\forall j \in F \cup X \cup W, \exists c \in NC, f_i = f_c$$

2. Global Optimization and Evolutionary Strategy

Engineering optimization problems are often formulated as non-convex MINLP models. Recent developments in the stochastic and deterministic algorithms for solving MINLP models have been thoroughly reviewed by Floudas et al. [20]. It is well recognized that none of the available generic methods can be applied successfully to all problems without the aid of case-specific insights and sometimes even a good local optimum cannot be guaranteed. In the present study, by incorporating both deterministic and stochastic components, a hybrid optimization strategy is developed with iterative procedures to enhance the solution quality. The proposed solution pro-

cedure can be broadly divided into two stages. Stage I is designed to get a set of feasible solutions on a sequential procedure and then pass the relevant variables to Stage II as initial values; while Stage II is focused on synthesizing the WAHEN simultaneously. The specific solution strategy in stage two can be also divided into two steps. The first step is designed to generate a set of feasible solutions and identify the candidate region for refined search, while the second is aimed to locate the true optimum with DICOPT solver [21]. Notice that the overall procedure is still required to be carried out repeatedly for different number of event points with various seeds used for the pseudo random number generator.

Before carrying out the proposed solution procedure, it is helpful to first determine the upper and lower bounds of freshwater and

utility consumption rates. In particular, the maximum freshwater supply and wastewater discharge can be determined by excluding all wastewater-treatment units and all water-reuse opportunities. In the first step of stage II, after all parameters are prepared, all the specified variables will undergo stochastic mutation by introducing no more than ten percent random perturbations into the initial values generated in stage I. Then, the WUN-HEN MINLP problem will be solved with DICOPT solver in GAMS environment by rounding the binary variables to 0 or 1. However, if the solution process of the original MINLP model is not convergent, the search procedure should be restarted by generating another set of initial guesses randomly. The procedure is repeated until feasible solutions can be obtained and these solutions are regarded as initial values in the refined search. In the next step, perturbations will first be introduced into the solutions found in step one based on the marginal values of the variables in GAMS solution report in the first step. This model is then solved with perturbed initial guesses for improved solutions.

Furthermore, in this study, evolutionary strategies are introduced to adjust the aforementioned WAHEN structures. Specifically, heat loads are shifted around loops and along paths to reduce exchanger number [22]. On the basis of tearing heat duty loops and relaxing heat duty paths, effective heat exchange matches are realized between the main of fresh water and wastewater. Stream mixings are

introduced into direct heat exchanges; therefore, isothermal mixing limitation is broken through. With the help of case specific insights, the solution process can be made more efficient by driving the search to a much more restricted region. Then, certain manipulations can be performed in modified networks to further optimize our preliminary solutions, and it has been proved that such solutions cannot be discovered with an automatic computer algorithm.

APPLICATION EXAMPLES

The effectiveness of the theoretical methods above can be proved by calculation examples from the literature, and the two examples are a single contaminant system and a multi contaminant system, respectively. A set of common model parameters are used in the two examples. The cost of 20 °C fresh water and 80 °C fresh water are chosen to be 0.375\$/t and 0.45\$/t, respectively, the inlet and outlet temperatures of cooling water are set at 10 °C and 20 °C, respectively, and its cost is 189\$/a; the temperatures of steam is assumed to be 120 °C and 150 °C respectively, and the corresponding cost is 377/(kW·a) and 388/(kW·a); and the overall heat transfer coefficient is assumed to be 0.8517 kW/(m²·°C). The annualized capital cost model for a conventional heat exchanger is 8000y_{i,j}+1200A_{i,j}^{0.6}, where the heat transfer area A_{i,j} is in m² [23,24]. Finally, the annual

Table 1. Operating given data of single contaminant system

Water utilization unit	Contaminant load Δm/(g·s ⁻¹)	Maximum inlet concentration C _{in} ^{max} /(mg·l ⁻¹)	Maximum outlet concentration C _{out} ^{max} /(mg·l ⁻¹)	Flow rate limit f ^{lim} /(kg·s ⁻¹)	Operation temperature t/(°C)
1	2	0	100	20	40
2	5	50	100	100	100
3	30	50	800	40	75
4	4	400	800	10	50

The note: Fresh water source temperature TS=20 °C, waste water discharge temperature TD=30 °C

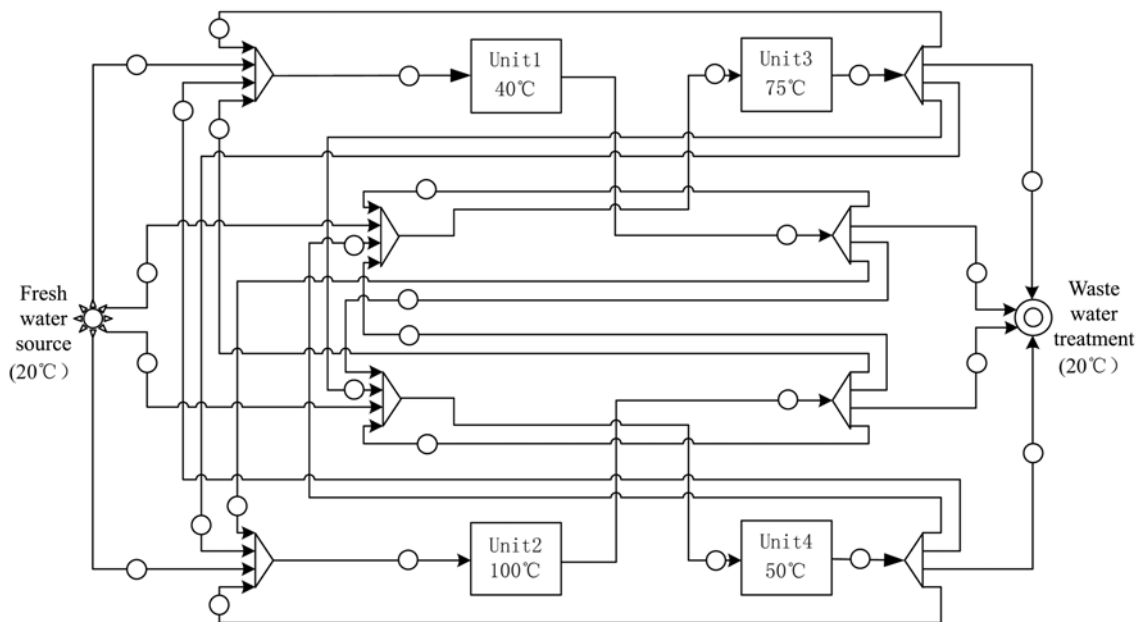

Fig. 7. Single contaminant system WUN-HEN flow sheet topology connections (The note: Matching heat exchange can exist between any two streams).

interest rate is set at 10% and the plant is assumed to be operated continuously for 8,000 hours a year. In the result of simultaneous calculation, not only a better optimization network is achieved than sequential calculation, but also several near-optimal solutions are also found which include the results of sequential calculation, so that various reserved choices are offered for process design.

1. WUN of Single Contaminant with Energy Integration

Let us first consider the process data presented in Table 1 [13-16]. Moreover, to be able to compare different strategies on the same basis, let us assume that TACs of the published network structures can be calculated according to the aforementioned cost models. Based on the conceptual design method, Savulescu et al. [15,16] obtained a WAHEN design which consumes the smallest amount of fresh-water (90 kg/s). There is 1 cooler, 1 heater and 3 heat exchangers in this network. The TAC and the annualized capital investment of this system are estimated to be 2,910,284 and 191,774USD/a, respectively. The corresponding consumption rates of cooling water and hot utility (MPsteam) are 485 and 4,265 kW, respectively. On the other hand, with the mathematical programming models, Bagajewicz et al. [14] synthesized another WAHEN, which requires the same freshwater supply rate. Three heat exchangers and one heater are needed in this design. The estimated TAC and annualized capital investment in this case are 2,626,476 and 229,416USD/a, respectively. The corresponding consumption rate of hot utility (LP steam) is 3,780 kW.

Based on the WU-HEN topology presented in Fig. 7, the overall distribution of TAC function to total flow rate of fresh water is shown in Fig. 8, and the optimization result of sequential calculation lies in (90, 2646472), which means minimum fresh water consumption is 90 kg/s and TAC is 2646472\$/a. In simultaneous optimization, the approach of determining the water consumption interval of sensitivity analysis is described as follows: The lower bound is determined by the result of sequential calculation, which means the minimum fresh water consumption is 90 kg/s when all the water is reused, the medium bound is determined according to the state that maximum fresh water consumption is 112.5 kg/s when only fresh water is used, and the upper bound is determined according to the state that maximum water reused is 170 kg/s when the water consumption reaches the maximum limit. From the results, state points of feasible solutions distribute in the whole flow rate range. When the total flow rate of fresh water is 90 kg/s, the TAC function has a

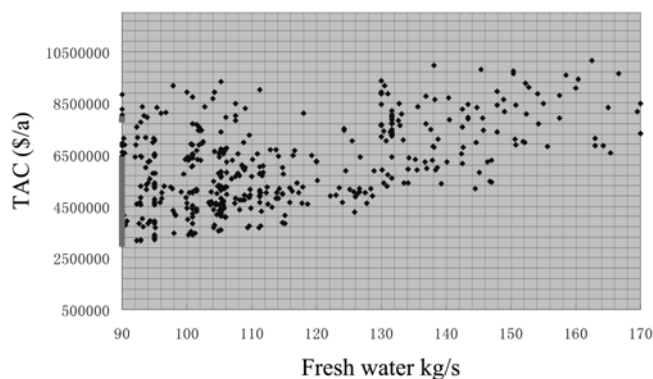

Fig. 8. Distribution of total annual cost function to total flow rate of fresh water.

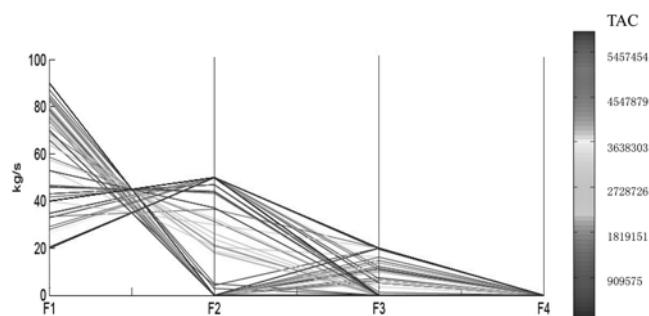

Fig. 9. Distribution of total annual cost function to individual flow rate of fresh water.

minimum value 2646472\$/a. Moreover, the brighter area shows the results of sequential or refined search clustering, and in this problem, the starting point of refined search is (90, 2646472) which is the optimal point of global search at the same time.

It is obvious that the minimum fresh water consumption achieved in simultaneous optimization is the same as the result obtained in sequential optimization, which reflects that fresh water consumption and utility consumption are weighed in the same direction in this problem; however, the TAC achieved in simultaneous optimization is lower than that in sequential optimization. Therefore, the network structure established in simultaneous optimization is simpler. The local distribution of TAC function to individual flow rate of fresh water of water utilization units is shown in Fig. 9. The network structure of WU-HEN and utility expenditures are changed with the distribution of individual flow rate of fresh water of water utilization units. In the figure, the total flow rate of fresh water is specified to 90 kg/s, that is, $F_1 + F_2 + F_3 + F_4 = \text{constant}$, so distribution points are in the same plane ($\vec{1}, \vec{1}, \vec{1}, \vec{1}$). The individual flow rate range of fresh water of water utilization units is determined by appropriately increasing disturbance based on the initial value [40, 50, 0, 0] of global search calculation result.

From the results, when individual flow rate of fresh water of water utilization units is [20, 50, 20, 0] kg/s, there are 2 heaters and 3 heat exchangers in this network, the consumption of hot utility is 3,780 kW, the minimum TAC and the annualized capital investment were found to be 2646472\$/a and 249412\$/a, while sequential calculation result shows that individual flow rate of fresh water of water utilization units is [40, 50, 0, 0] kg/s, and TAC function has a value of 2672682\$/a, which reflects that distribution of fresh water consumption of water utilization units achieved by the simultaneous approach is better than the result of sequential approach in the condition that the total flow rates of fresh water remain the same. WUN and HEN structures established by sequential and simultaneous strategies are shown in Fig. 10 and Fig. 11 respectively. Comparing the two structures, the network structure established by sequential strategy is more complex. The reason is that fresh water consumption, utility consumption and equipments cost can be weighed simultaneously by simultaneous strategy; therefore, a compromise network structure can be achieved. The comparison of each cost obtained by the sequential and simultaneous methods is shown in Table 2. We can see that though fresh water consumption, cold and hot utilities consumptions are all the same, equipment cost of the simultaneous method is lower, and network TAC is reduced compared with

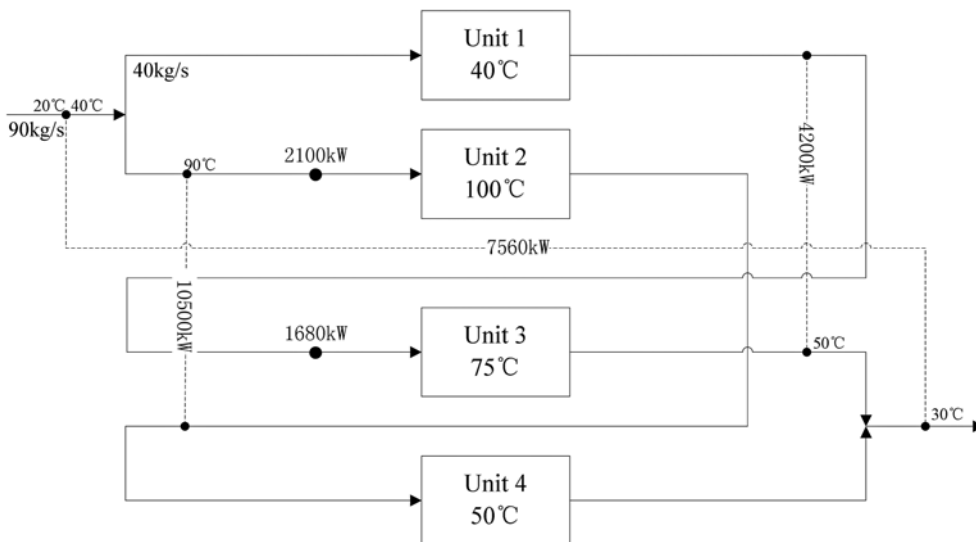

Fig. 10. The optimal network structure in example 1 (sequential).

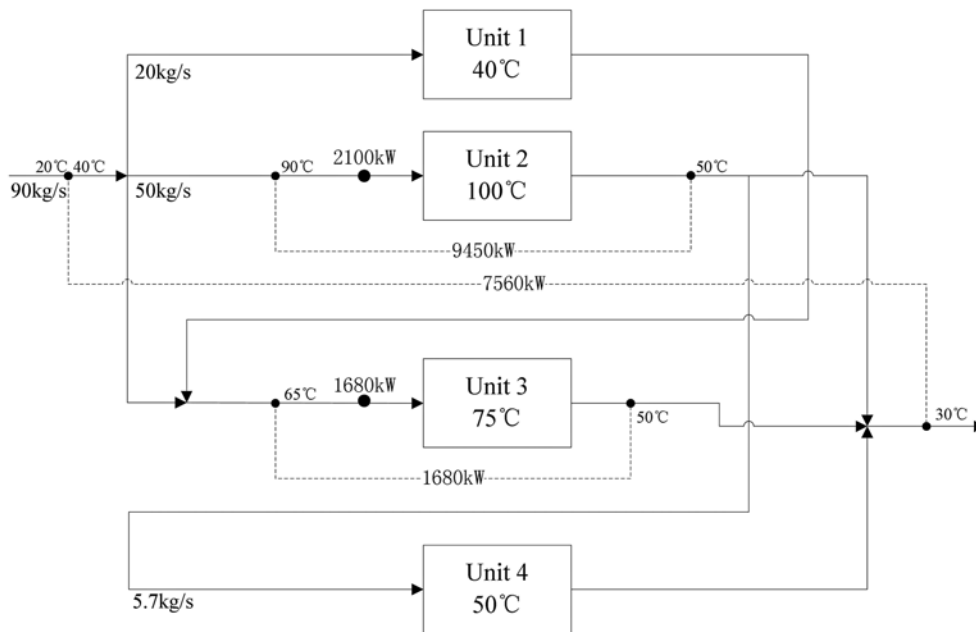

Fig. 11. The optimal network structure in example 1 (simultaneous).

Table 2. Compare individual cost of single contaminant system

	TAC (\$/a)	Fresh water FW/(\$/a)	Cold utility CCU (\$/a)	Hot utility HCU (\$/a)	INVCOST (\$/a)	
Bagajewicz et al. [14]	2626476	972000	0	1425060	229416	
Savulescu et al. [15,16]	2910284	972000	91665	1654846	191774	
Sequential synthesis in the paper	2672682	972000	0	1425060	318148	
Simultaneous synthesis in the paper	Global search	2646472	972000	0	1425060	249411.6
	Local search	2646472	972000	0	1425060	249411.6

the result of sequential synthesis with an absolute drop of 26211\$/a (its relative drop is 1.0%); therefore, the cost factors can be weighed effectively within simultaneous strategy.

2. WUN of Multi Contaminants with Energy Integration

The data of the multi contaminant system example is taken from literature [25], and the temperature data are determined according

Table 3. Operating given data of multi contaminant system

Water utilization unit	Contaminant	Contaminant load $\Delta m/(g \cdot s^{-1})$	Maximum inlet concentration $C_{in}^{max}/(mg \cdot l^{-1})$	Maximum outlet concentration $C_{out}^{max}/(mg \cdot l^{-1})$	Operation temperature $t/(^{\circ}C)$
1	A	3.0	0	100	100
	B	2.4	0	80	
	C	1.8	0	60	
2	A	4.0	50	150	75
	B	3.0	40	115	
	C	3.6	15	105	
3	A	1.5	50	125	35
	B	0.6	50	80	
	C	2.0	30	130	

The note: Fresh water source temperature $TS=80^{\circ}C$, waste water discharge temperature $TD=60^{\circ}C$

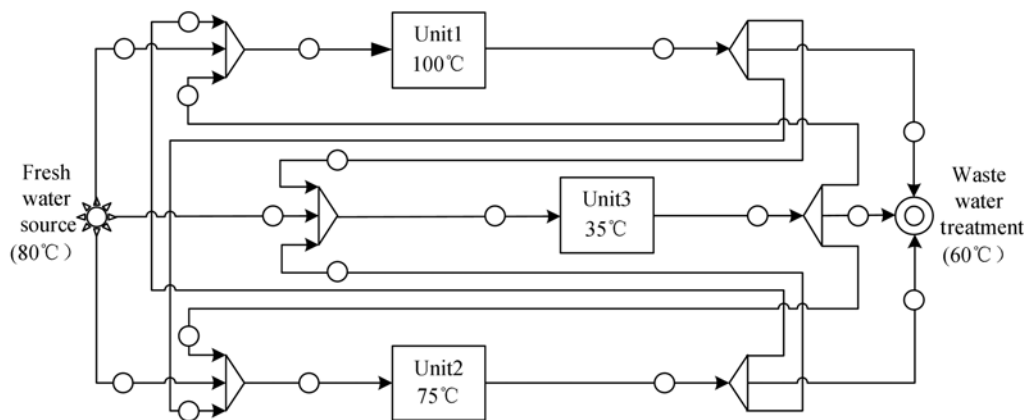
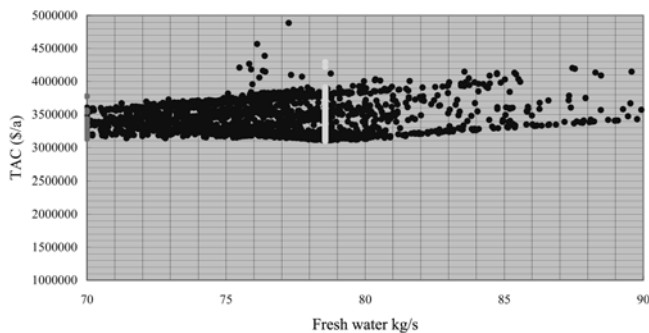
**Fig. 12. Multi contaminant system WUN-HEN flow sheet topology connections.****Fig. 13. Distribution of total annual cost function to total flow rate of fresh water.**

to petrochemical typical processes. The original operation data are shown in Table 3, and related flows topology connections of WU-HENs are shown in Fig. 12.

The overall distribution of TAC Function to total flow rate of fresh water is shown in Fig. 13. In this figure, the optimization result of sequential calculation lies in (70, 3132890), which means minimum fresh water consumption is 70 kg/s, and TAC is 3146834\$/a.

In the process of simultaneous optimization, the approach of determining the water consumption interval of sensitivity analysis is described as follows. The lower bound is determined by the result

of sequential calculation, which means the minimum fresh water consumption is 70 kg/s when all the water is reused, the medium bound is determined according to the state that maximum fresh water consumption is 79.67 kg/s when only fresh water is used, and the upper bound is determined according to the state that maximum water reused is 90 kg/s when the water consumption reaches the maximum limit. From the results, state points of feasible solutions distribute densely and macroscopically in the whole flow rate range. When the total flow rate of fresh water is 78.57 kg/s, the TAC function has a minimum value 3099583\$/a. Moreover, the brighter area shows the results of sequential or local search clustering, and in this problem, the starting point of local search is (78.57, 3105316), which is the optimal point of global search at the same time.

It is obvious that the minimum fresh water consumption achieved in simultaneous optimization is different from the result obtained in sequential optimization, which reflects that fresh water consumption and utility consumption are weighed in opposite directions in this problem. However, the TAC achieved in simultaneous optimization is lower than that in sequential optimization; therefore, the network structure established in simultaneous optimization is more succinct.

The local distribution of TAC function to individual flow rate of fresh water of water utilization units is shown in Fig. 14. In the figure, the total flow rate of fresh water is specified to 78.57 kg/s, that is, $F_1 + F_2 + F_3 = \text{constant}$, so distribution points are in the same plane $(\vec{1}, \vec{1}, \vec{1})$.

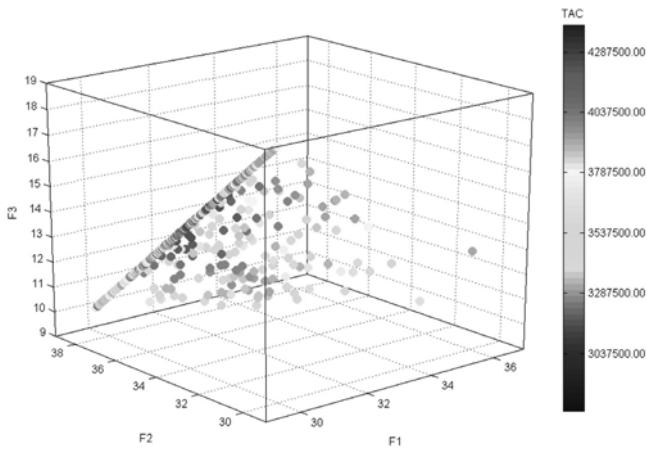

Fig. 14. Distribution of total annual cost function to individual flow rate of fresh water.

Each flow rate range of fresh water of water utilization units is determined by appropriate increase disturbance based on the initial value (30, 34.3, 14.3) of the global search calculation result.

From the results, when the individual flow rate of fresh water of water utilization units is [30, 34.3, 14.3] kg/s, there is 1 heater, 3 coolers and 1 heat exchanger in this network, the consumption of hot utility and hot utility is 1,260 kW and 7,863 kW separately, the minimum TAC and the annualized capital investment were found to be 3099583\$/a and 119800\$/a, while sequential calculation result shows that individual flow rate of fresh water of water utilization units is [30, 30, 10] kg/s, and TAC function is 3146834\$/a, which reflects that distribution of fresh water consumption of water utilization units achieved by the simultaneous approach is better than the result of sequential approach in the condition that the total flow rates of fresh water are different.

WU-HENs structures established by sequential and simultaneous strategies are shown in Fig. 15 and Fig. 16, respectively. Comparing the two structures, the network structure established by the sequential strategy is more complex, because fresh water consumption, utility consumption and devices cost can be weighed simultaneously within a simultaneous strategy; therefore, a compromise network structure can be achieved.

The comparison of each cost resulting from the sequential and simultaneous strategies is shown in Table 4. We can see that through

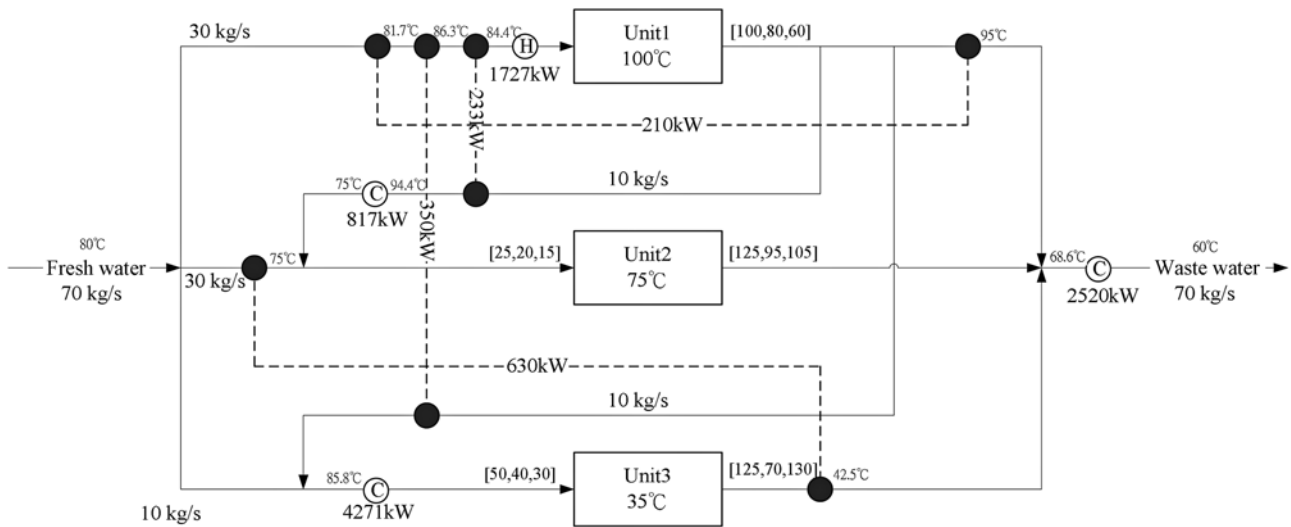

Fig. 15 The optimal network structure in example 2 (sequential).

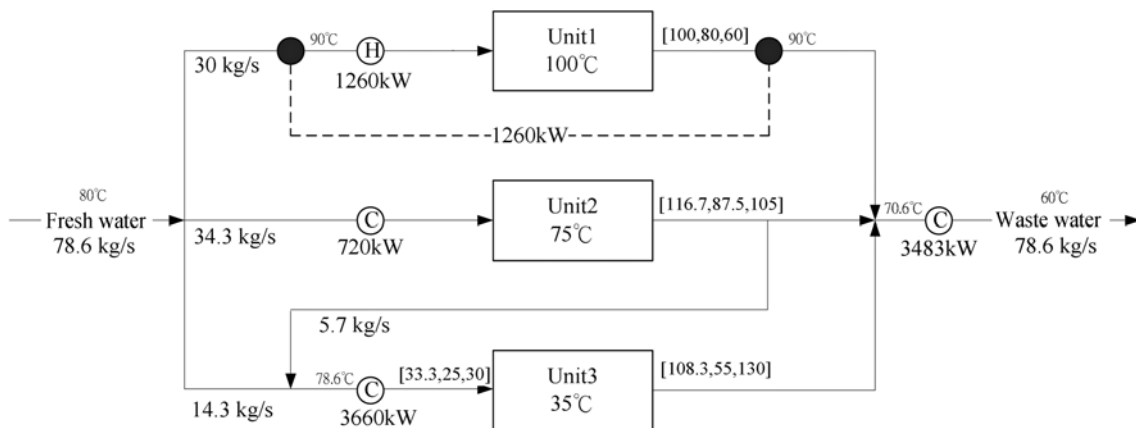

Fig. 16. The optimal network structure in example 2 (simultaneous).

Table 4. Compare individual cost of multi contaminant system

		TAC (\$/a)	Fresh water FW/(\$/a)	Cold utility CCU (\$/a)	Hot utility HCU (\$/a)	INVCOST (\$/a)
Sequential synthesis		3146834	907200	1437912	651079	196381
Simultaneous synthesis	Global research	3105697	1018656	1424155	475095	187781
	Local research	3099583	1018656	1486107	475020	178441

fresh water consumption, the cold utility consumption of simultaneous synthesis result is a little higher, but hot utility consumption and equipment cost of the simultaneous strategy are lower, so the network TAC is obviously reduced compared with the result of sequential synthesis with an absolute drop of 47252\$/a (its relative drop is 1.5%). Thus, the cost factors can be weighed effectively within the simultaneous strategy. On the basis of the designs produced in this example, it can be concluded that the proposed method is indeed suitable for applications in multi-contaminant systems. In fact, this issue has never been properly addressed in any of the previous studies.

CONCLUSIONS

In this work, HMP has been introduced for simultaneous integration of WU-HEN designs. Better trade-offs between fresh water consumption and utility consumption can be addressed and optimal overall designs can be generated accordingly. Furthermore, a hybrid optimization strategy based on the stochastic and deterministic search techniques has been developed in this work to guarantee the solution quality and efficiency. By interactively applying random perturbations based on the sensitivity analysis in this strategy, the optimal solution can almost always be identified in all case studies presented in this paper. Finally, evolutionary strategies are adopted to overcome the inherent deficiencies of the obtained configurations.

ACKNOWLEDGMENT

This work was supported by the National Natural Science Foundation of China (20876020), the National Science Council of ROC government under grant NSC 95-2221-E-006-421 and the Talent Startup Funding of Dalian University of Technology (China, No. 1000-893368).

NOMENCLATURE

A : heat transfer area [m^2]
 B : exponent for area cost
 C : area cost coefficient; concentration of contaminant [$\text{mg}\cdot\text{L}^{-1}$]
 C_{fw} : the unit prices coefficient of the fresh water
 $C_{i,k,in}^{max}$: inlet maximum allowed contaminant concentration limit [$\text{mg}\cdot\text{L}^{-1}$]
 $C_{i,k,out}^{max}$: outlet maximum allowed contaminant concentration limit [$\text{mg}\cdot\text{L}^{-1}$]
 C_{cu} : per unit cost for cold utility [$\text{\$}\cdot\text{kW}^{-1}$]
 C_{hu} : per unit cost for hot utility [$\text{\$}\cdot\text{kW}^{-1}$]
 Cf : fixed cost for heat exchangers [$\text{\$}$]
 dt : the approach temperatures [$^{\circ}\text{C}$]
 f : supplied flow rate of fresh water [$\text{kg}\cdot\text{s}^{-1}$]
 F : set of fresh water stream

fh, fc : heat capacity flow rate of hot and cold streams [$\text{kW}\cdot^{\circ}\text{C}^{-1}$]
 k : heat transfer film coefficients of stream [$\text{kW}\cdot\text{m}^{-2}\cdot^{\circ}\text{C}^{-1}$]
 K : overall heat transfer coefficient [$\text{kW}\cdot\text{m}^{-2}\cdot^{\circ}\text{C}^{-1}$]
 N_H, N_C : number of hot and cold process streams
 N_k : number of stages
 q_{cui} : heat load of cooler for hot stream i [kW]
 q_{huj} : heat load of heater for cold stream j [kW]
 q_{ijk} : heat exchanged between hot stream i and cold stream j in stage k [kW]
 TH_{in}, TC_{in} : inlet temperatures of hot and cold streams [$^{\circ}\text{C}$]
 TH_{out}, TC_{out} : outlet temperatures of hot and cold streams [$^{\circ}\text{C}$]
 tc_{ijk} : temperatures of branch of cold stream j at hot end of match (i, j) in stage k [$^{\circ}\text{C}$]
 tc_{jk} : temperatures of cold stream j at hot end of stage k [$^{\circ}\text{C}$]
 th, tc : temperatures of hot and cold streams [$^{\circ}\text{C}$]
 th_{ijk} : temperatures of branch of hot stream i at cold end of match (i, j) in stage k [$^{\circ}\text{C}$]
 th_{jk} : temperatures of hot stream i at cold end of stage k [$^{\circ}\text{C}$]
 W : discharged flow rate of waste water, $\text{t}\cdot\text{h}^{-1}$; set of waste water stream
 X : flow rate of the water stream, $\text{t}\cdot\text{h}^{-1}$; set of reused process water stream
 $X_{i,j}$: flow rate of the reused process water from j to i [$\text{t}\cdot\text{h}^{-1}$]
 y : binary variable
 Δm : contaminant load [$\text{kg}\cdot\text{h}^{-1}$]

Subscripts

cu : cold utility
 hu : hot utility
 i : hot process stream; hot water stream
 in : inlet
 j : cold process stream; cold water stream
 k : stage number. contaminant
 out : outlet

Sets

NH = {i|j is a hot process stream}
 NC = {j|j is a cold process stream}
 NK = {k|k is a stage in the superstructure}

REFERENCES

1. B. Linnhoff and E. Hindmarsh, *Chem. Eng. Sci.*, **38**(5), 745 (1983).
2. M. M. El-Halwagi and V. Manousiouthakis, *AIChE J.*, **35**(18), 1233 (1989).
3. Y. P. Wang and R. Smith, *Chem. Eng. Sci.*, **49**(7), 981 (1994).
4. I. E. Grossmann, J. A. Caballero and H. Yeomans, *Advances in mathematical programming for automated design*, Integration and Operation of Chemical Processes, Carnegie Mellon University (1999).

5. C. A. Floudas, A. R. Ciric and I. E. Grossmann, *AIChE J.*, **32**, 276 (1986).
6. T. F. Yee, I. E. Grossmann and Z. Kravanja, *Comput. & Chem. Eng.*, **14**(10), 1151 (1990).
7. T. F. Yee and I. E. Grossmann, *Comput. & Chem. Eng.*, **14**(10), 1165 (1990).
8. A. Barbaro and M. J. Bagajewicz, *Comput. & Chem. Eng.*, **29**(9), 1945 (2005).
9. N. Takama, T. Kuriyama, K. Shiroko and T. Umeda, *Comput. & Chem. Eng.*, **4**(4), 251 (1980).
10. A. Alva-Argaez, A. Kokossis and R. Smith, *Comput. & Chem. Eng.*, **22**(Suppl.), 741 (1998).
11. C. H. Huang, C. T. Chang, H. C. Ling and C. C. Chang, *Ind. Eng. Chem. Res.*, **38**, 2666 (1999).
12. M. Savelski and M. Bagajewicz, *On the use of linear models for the design of water utilization systems in refineries and process plants*, AIChE Annual Meeting, Dallas (1999).
13. L. E. Savulescu and R. Smith, *Simultaneous energy and water minimization*, AIChE Annual Meeting, Miami (1998).
14. M. J. Bagajewicz, H. Rodera and M. J. Savelski, *Comput. & Chem. Eng.*, **26**, 59 (2002).
15. L. Savulescu, J.-K. Kim and R. Smith, *Chem. Eng. Sci.*, **60**(12), 3279 (2005).
16. L. Savulescu, J. K. Kim and R. Smith, *Chem. Eng. Sci.*, **60**(12), 291 (2005).
17. L. Savulescu, M. Sorin and Smith, *Applied Thermal Engineering*, **22**(8), 981 (2002).
18. M. J. Savelski and M. J. Bagajewicz, *Chem. Eng. Sci.*, **55**(21), 5035 (2000).
19. K. P. Papalexaddri and E. N. Pistikopoulos, *Comput. & Chem. Eng.*, **18**, 1125 (1994).
20. C. A. Floudas, I. G. Akrotirianakis, S. Caratzoulas, C. A. Meyer and J. Kallrath, *Comput. & Chem. Eng.*, **29**, 1185 (2005).
21. J. Viswanathan and I. E. Grossmann, *Comput. & Chem. Eng.*, **14**, 769 (1990).
22. J. L. Su and R. L. Motard, *Comput. & Chem. Eng.*, **8**, 67 (1984).
23. S. Ahmad, B. Linnhoff and R. Smith, *Comput. & Chem. Eng.*, **14**, 751 (1990).
24. B. Linnhoff and S. Ahmad, *Comput. & Chem. Eng.*, **14**, 729 (1990).
25. J. G. Mann and Y. A. Liu, *Industrial water reuse and wastewater minimization*, McGraw-Hill (1999).
26. M. C. Ferris, MATLAB and GAMS: Interface optimization and visualization software, <http://www.cs.wisc.edu/math-prog/matlab.html> (2005).
27. R. V. Hogg and J. Ledolter, *Engineering statistics*, MacMillan (1987).
28. L. Kaufman and P. J. Rousseeuw, *Finding groups in data: An introduction to cluster analysis*, Wiley (1990).
29. B. H. Li and C. T. Chang, *Ind. Eng. Chem. Res.*, **44**(10), 3607 (2005).

Retraction: “Simultaneous optimal integration of water utilization and heat exchange networks using holistic mathematical programming”
[Korean J. Chem. Eng., 26(5), 1161 (2009)]

Wu Xiao*, **Rui-jie Zhou*****, **Hong-Guang Dong*†**, **Nan Meng***, **Chih-Yao Lin****,
and **Vincentius Surya Kurnia Adi****

*School of Chemical Engineering, Dalian University of Technology, Dalian 116012, Liao Ning, PRC

**Department of Chemical Engineering, National Cheng Kung University, Tainan 70101, Taiwan, ROC

***Department of Economics, Dalian University of Technology, Dalian 116024, Liao Ning, PRC

The corresponding author hereby submit a retraction email of the above articles. The corresponding author failed to inform Professor CT Chang that his graduate students, C. Y. Lin and V.S.K. Adi, were listed as the co-authors and the NSC project number was quoted in the acknowledgement without his permission. An almost identical

paper had been published on-line in Chemical Engineering Journal and withdrawn by the same corresponding author and there were also some mistakes in KJChE manuscript. The corresponding author deeply regrets the uncaredful publication.

†To whom correspondence should be addressed.
E-mail: hgdong@dlut.edu.cn

DOI: 10.1007/s11814-010-0158-y

Correction: “Characterization of thiourea-formaldehyde chelating resin by sorption of chromium(III) in water”
[Korean J. Chem. Eng., 26(6), 1717 (2009)]

Ki Young Kim, Ki-Taek Byun, and Ho-Young Kwak†

Mechanical Engineering Department, Chung-Ang University, seoul 156-756, Korea

The title of this article should be corrected to “**Mesoscopic simulation for the structural change of a surfactant solution using**

dissipative particle dynamics” because of an error in the editing process.

†To whom correspondence should be addressed.
E-mail: kwakhy@cau.ac.kr